

INSTALLATION INSTRUCTIONS

Accessory
SIDE STRAKES

Application
2003 S2000

Publications No.
All 24246

Issue Date
SEP 2002

PARTS LIST

Left upper side strake

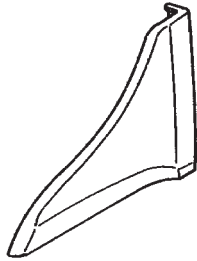

Right upper side strake

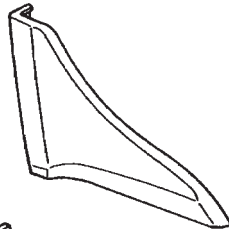

Left lower side strake

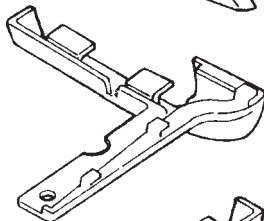

Right lower side strake

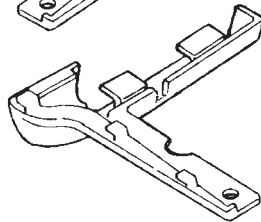

Template

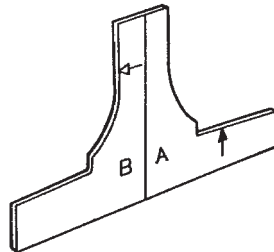

2 Turn nuts



2 Pins



2 Grommets



2 Butyl O-rings



2 Washer-screws, 6 x 20 mm



2 Clips A



Clip B (driver's side)

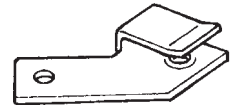

Clip B (passenger's side)

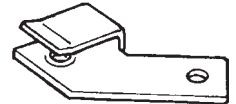

4 Small screws



4 Clamps



4 Protective seals



2 Washer-screws, 5 x 16 mm



2 Adhesive seals



TOOLS AND SUPPLIES REQUIRED

Drill
3 mm, 8 mm, and 10 mm Drill bits
Eye protection (face shield, safety goggles, etc.)
Touch-up paint
Phillips screwdriver
Ratchet
5 mm Socket
Felt-tip pen
Center punch
Contact cleaner
Shop towel
File
Masking tape
Utility knife
Electrical tape
Tape measure

INSTALLATION

Customer Information: The information in this installation instruction is intended for use only by skilled technicians who have the proper tools, equipment, and training to correctly and safely add equipment to your car. These procedures should not be attempted by "do-it-yourselfers."

NOTE:

- These instructions show the left (driver's) side strake being installed. The same procedure applies to installing the right (passenger's) side strake.
- Be careful not to damage the body finish when drilling the holes.

1. Raise the car on a hoist, and remove the rear wheels.

2. Apply masking tape to the body surface in the two areas where you will drill holes. Refer to the illustrations below.
3. Use the tape measure to measure 24 mm back from the side sill joint, and position the template on the side sill as shown in position "A." Using a felt-tip pen, mark the side sill in position "A." Remove the template.

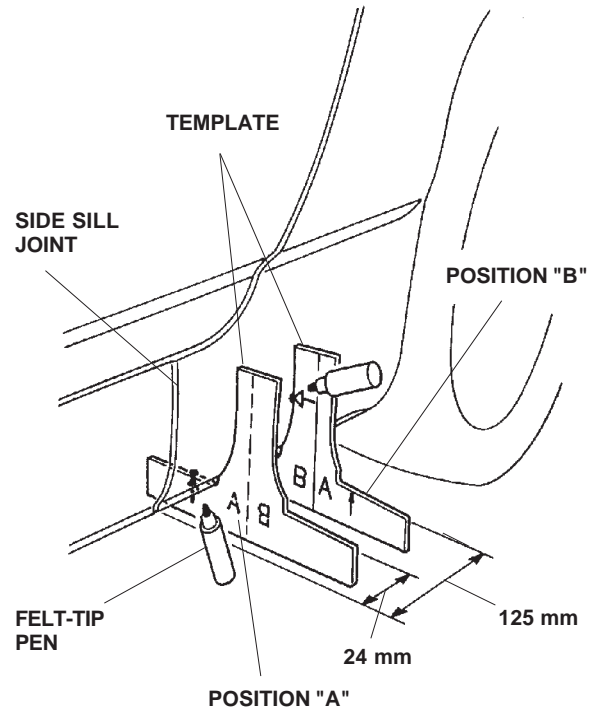

4. Use the tape measure to measure 125 mm back from the side sill joint. Turn the template around, and position the template on the side sill as shown in position "B." Using a felt-tip pen, mark the side sill in position "B." To ensure that the holes will be in the correct position, keep the template straight.
5. Lightly center-punch the two marks you made.

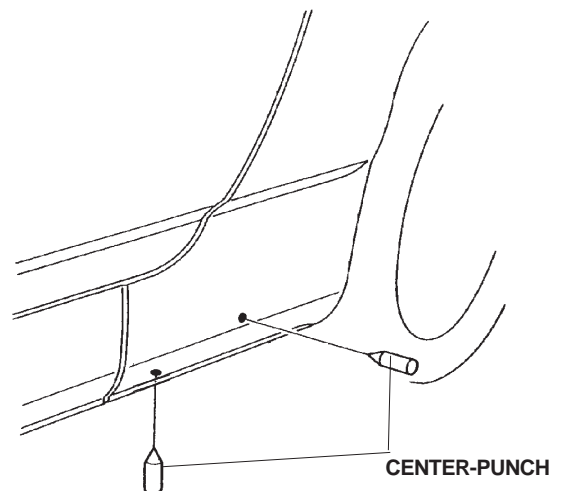

6. While wearing eye protection, drill an 8 mm hole through the upper center-punched mark:
 - Wrap electrical tape around the 3 mm and 8 mm drill bits about 10 mm from the end of each bit.
 - First drill with the 3 mm bit, and finish with the 8 mm bit.
 - Remove the masking tape from the hole area.
 - Remove any burrs, and apply touch-up paint to the edge of the hole you drilled.

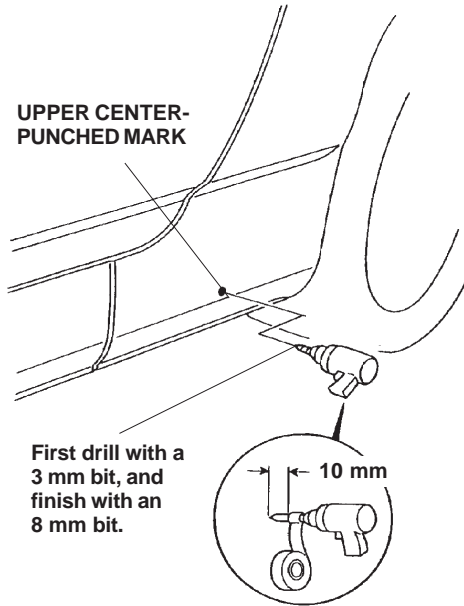

7. While wearing eye protection, drill a 10 mm hole through the lower center-punched mark:
 - Wrap electrical tape around the 10 mm drill bit about 10 mm from the end of the bit.
 - First drill with the 3 mm bit, then with the 8 mm bit, and finish with the 10 mm bit.
 - Remove the masking tape from the hole area.
 - Remove all burrs, and apply touch-up paint to the edge of the hole you drilled.

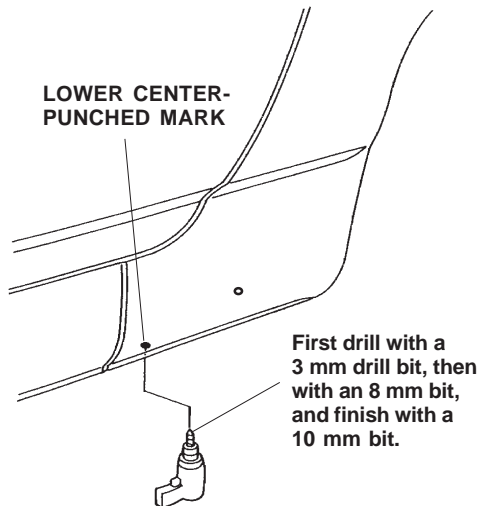

8. Install a grommet in the upper hole:
 - Remove the adhesive backing from one seal, and attach it over the 8 mm hole. Make sure the seal is centered over the 8 mm hole.
 - Install one grommet into the 8 mm hole through the seal. Make sure the tabs of the grommet are horizontal.

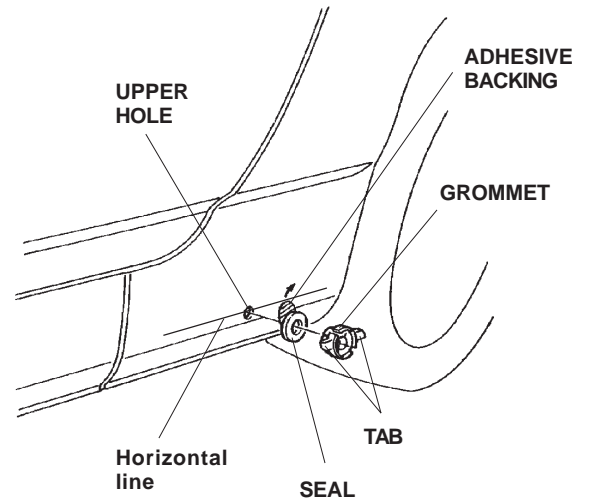

9. Install a turn nut into the lower hole:
 - Slide one butyl O-ring over the turn nut, then install the turn nut into the lower 10 mm hole.
 - Thread a 6 x 20 mm washer-screw into the turn nut until the turn nut is seated in the hole, then remove the washer-screw.

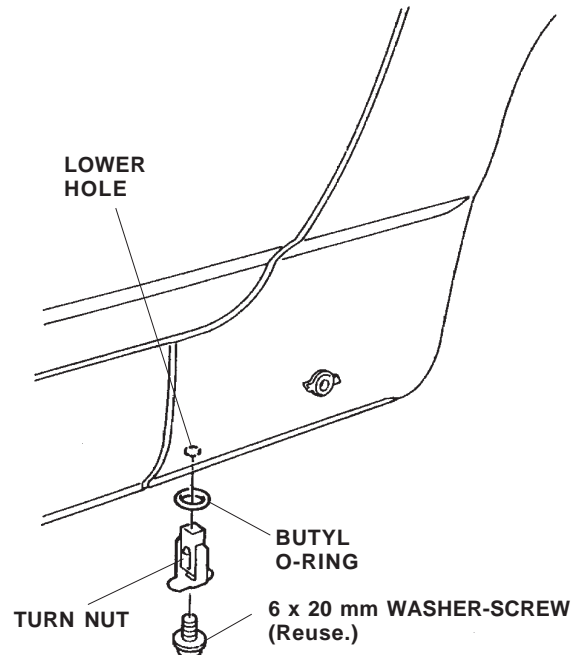

- Position the lower side strake on the body, and reinstall the 6 x 20 mm washer-screw. Secure the back of the side strake with two clamps. If necessary, remove any excess undercoating so the clamps attach securely. Tighten the 6 x 20 mm washer-screw and the clamps securely.

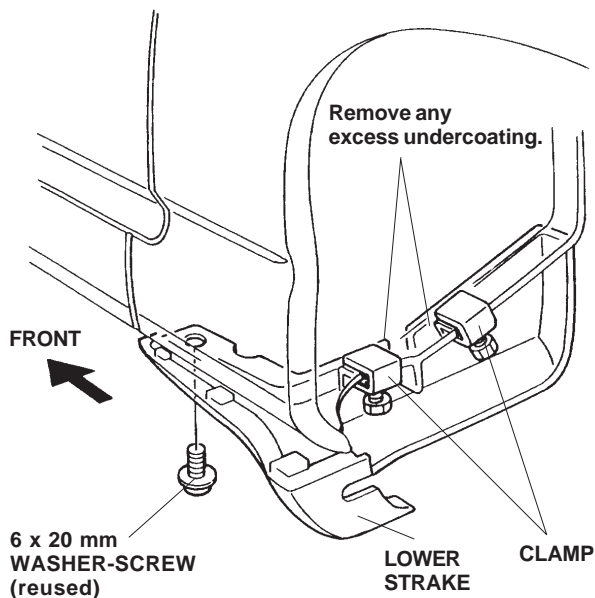

- Pull the inner fenderwell protector back out of the way.
- Get the left upper side strake, and temporarily fit the upper side strake into position on the fenderwell. Mark the fenderwell where the clips will attach.

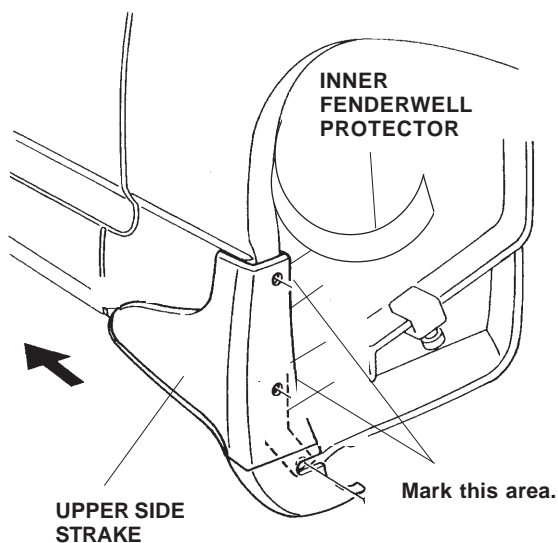

- Using contact cleaner on a shop towel, thoroughly clean the area where the clips will attach.
- Remove the adhesive backing from two of the protective seals, and attach them to the marked areas of the rear fenderwell.

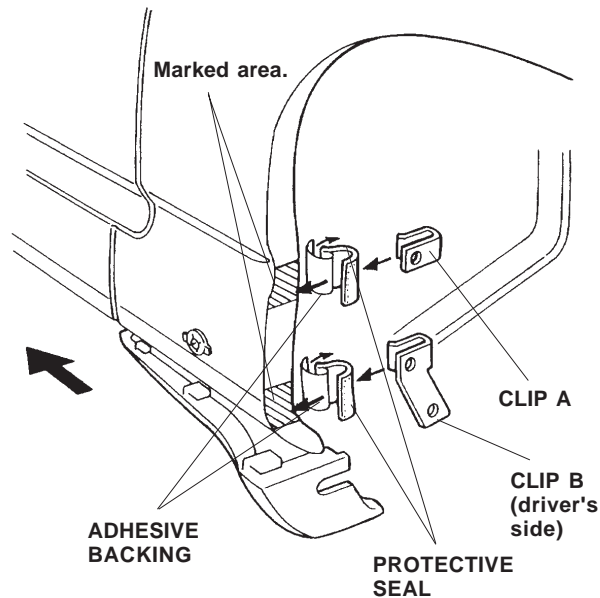

- Attach clip A over the upper protective seal, and attach clip B (driver's side) over the lower protective seal.
- Attach one pin to the inside of the upper side strake.

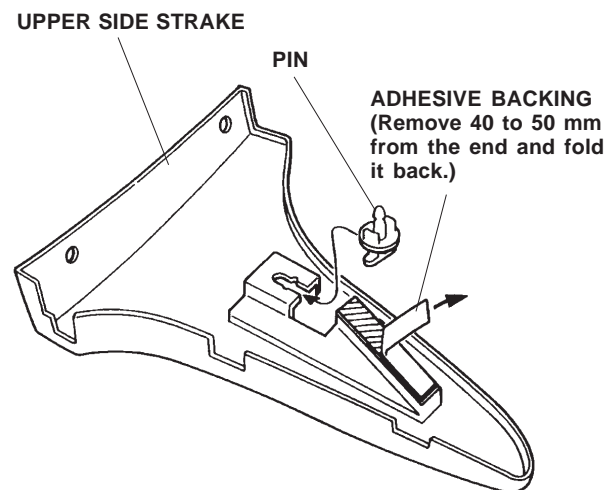

- Remove 40 to 50 mm of the adhesive backing from the adhesive tape, and fold it back as shown.

- Position the upper side strake on the lower side strake, and slide the upper strake forward to insert the tabs of the upper strake under the hooks on the lower strake.

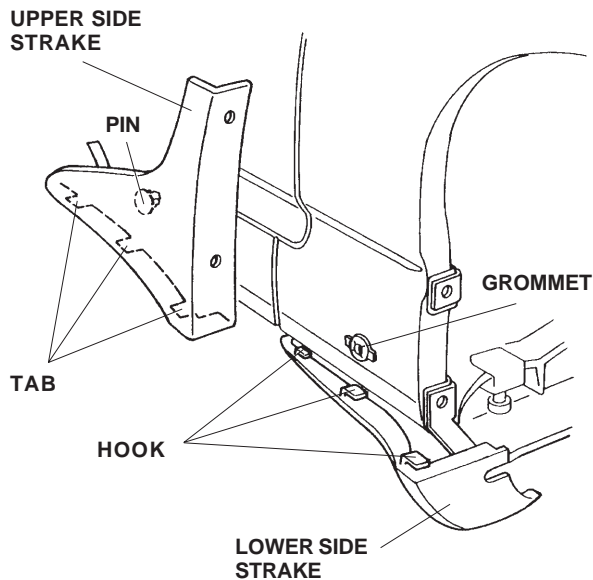

- Using the palm of your hand, push the pin on the upper strake into the grommet.
- Align the two holes in the upper side strake with the holes in clip A and clip B, and install one small screw into each clip.

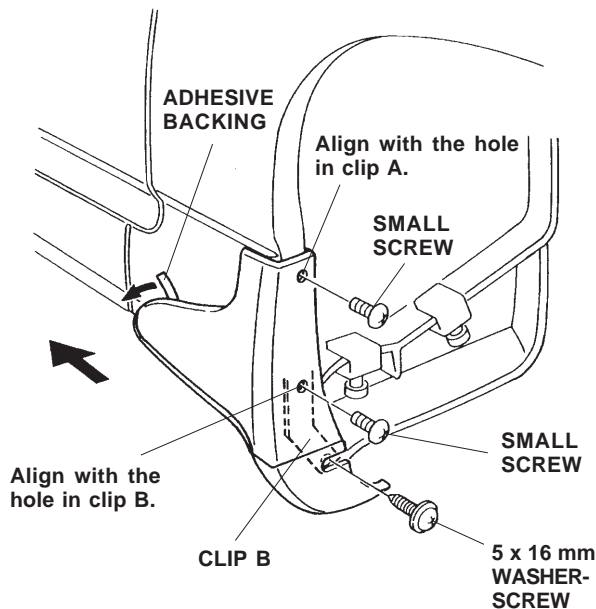

- Install the 5 x 16 mm washer-screw through the cutout in the lower side strake and into the hole in clip B.
- With the palm of one hand, hold the upper side strake against the body, and remove the adhesive tape.

- Reinstall the inner fenderwell protector. Using a utility knife, cut the inner fenderwell protector just above clip A; then tuck the inner fenderwell protector under the upper side strake.

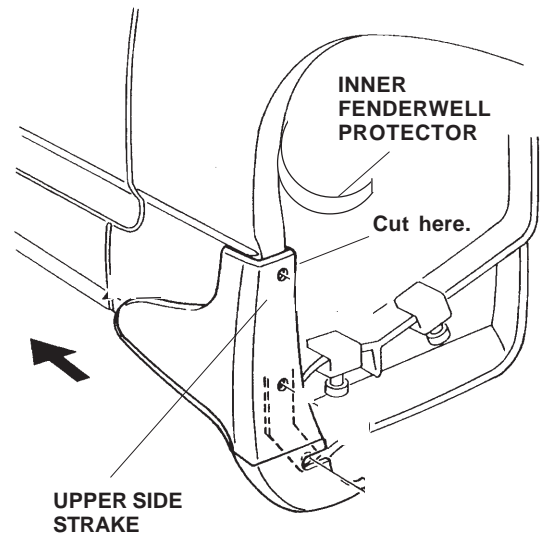

- Repeat steps 2 through 23 to install the right (passenger's) side strake.
- Reinstall the rear wheels.