



INSTALLATION INSTRUCTIONS

Accessory

REAR UNDER SPOILER

Application

2005 CIVIC SI

Publications No.

All 27954

Issue Date

AUG 2004

PARTS LIST

Rear under spoiler

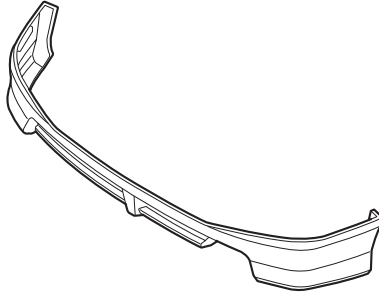

5 Stepped bolts



2 Self-tapping screws



2 Spring nuts



Template A

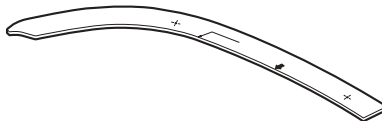

Template B

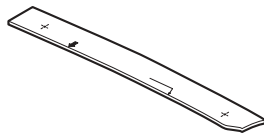

Template C



TOOLS AND SUPPLIES REQUIRED

Phillips screwdriver

Ratchet

10 mm Socket

Center punch

Drill

3 mm and 10 mm Drill bits

File

Isopropyl alcohol

Shop towel

Masking tape

Eye protection (face shield, safety goggles, etc.)

INSTALLATION

NOTE:

- Be careful not to damage the body finish when installing the rear under spoiler.
- Use two people to install the rear under spoiler.
- Make sure the area to be covered is clean and waxed with a high-quality paste wax. To prevent spilling, use a shop towel to apply isopropyl alcohol, and wipe up any spilled alcohol at once. Allow the isopropyl alcohol to dry thoroughly before installing the spoiler.
- Before removing parts, note their locations so they can be reinstalled in their original locations properly.
- This rear under spoiler kit should be installed only if the outside air temperature is 60°F (15°C) or above.
- To allow the adhesive to cure, do not wash the vehicle for 24 hours.

1. Remove the two self-tapping screws from the rear bumper. Thread the self-tapping screws into the two recesses at the left and right ends of the rear bumper. Remove the self-tapping screws, and install a spring nut over the hole you just made. The self-tapping screws will be installed later.

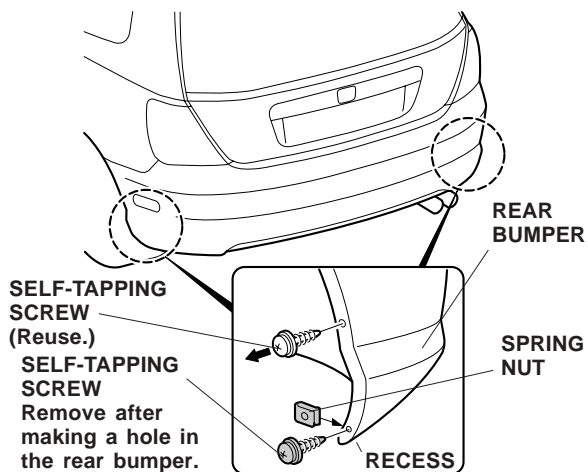

2. Attach template A, template B, and template C with adhesive tape along the lines on the inside of the lower side of the rear bumper as shown, and lightly mark with a center punch at the five marks printed on the templates. When all marks have been applied, remove the adhesive tapes and the templates.

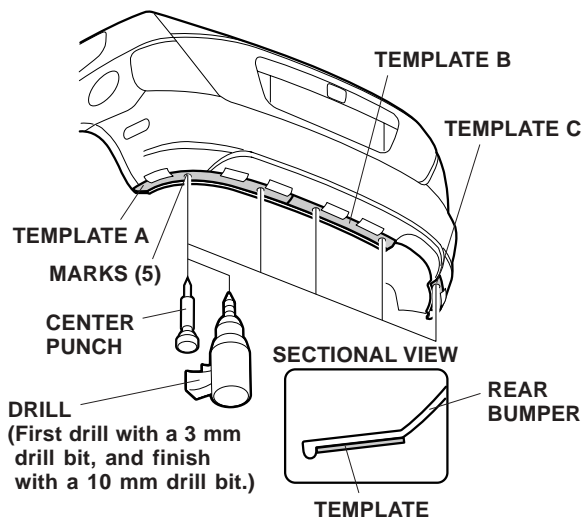

3. While wearing eye protection, drill a 10 mm hole through five marked locations. First drill with a 3 mm drill bit, and finish with a 10 mm drill bit. Remove all burrs from the edges of the hole with a file.

4. Using isopropyl alcohol, thoroughly clean the area where the rear under spoiler will be attached.

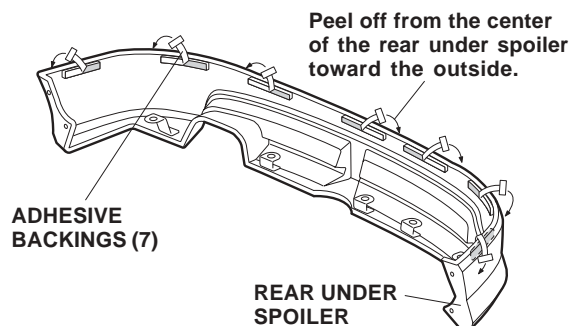

5. Inside the rear under spoiler, remove 3 to 5 cm (1 to 2 in.) of the adhesive backing from the end of each adhesive tape and fold them up. Attach a strip of masking tape to each adhesive tape, then attach the masking tape to the surface of the rear bumper as shown.
6. Attach the rear under spoiler to the rear bumper, install the five stepped bolts from the inside of the vehicle in the holes made in step 3, and tighten the bolts finger-tight.

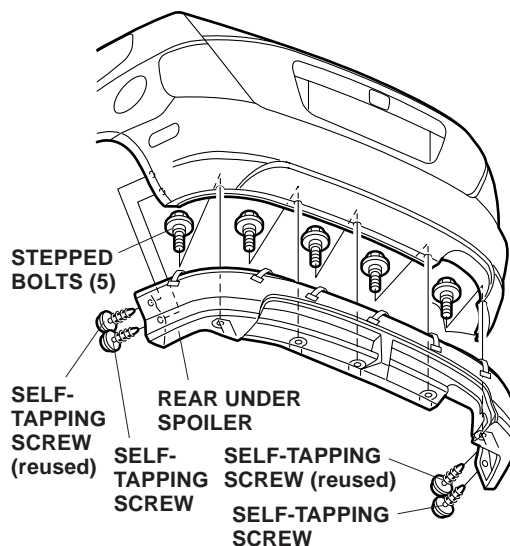

7. Install the four self-tapping screws to secure the ends of the rear under spoiler. Do not tighten the self-tapping screws yet.

8. Check that there is no clearance between the rear under spoiler and the rear bumper, and while holding pressure on the rear under spoiler, carefully remove the adhesive backings. When peeling off the adhesive backing, peel it off sequentially from the center of the rear under spoiler to the outside.

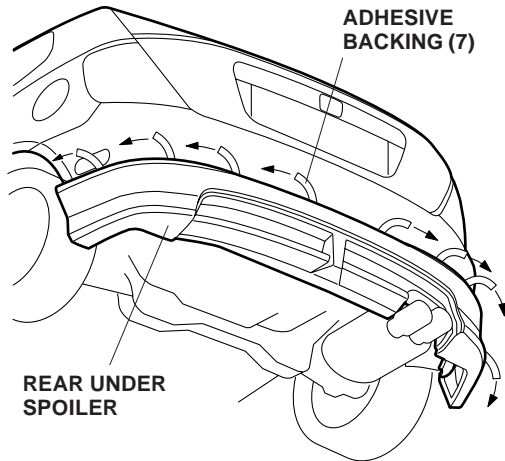

9. Attach the rear under spoiler securely by tightening the four self-tapping screws and the five stepped bolts.

Copy this page and give it to your customer.

- When towing a vehicle, follow the instructions described in the vehicle's owner's manual.
- When using the towing hook, be sure to remove both the rear bumper and the rear under spoiler. Failure to follow this precaution can damage the rear bumper, the rear under spoiler, and the vehicle.
- Actual vehicle may be different from the illustration.

