



INSTALLATION INSTRUCTIONS

Accessory

RUNNING BOARDS
P/N 08L33-S9V-100

Application

2003 PILOT

Publications No.

All 23627

Issue Date

MAY 2002

PARTS LIST

2 Running boards

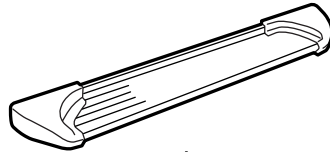

6 "A" Brackets



6 "B" Brackets

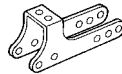

6 "C" Brackets



24 Long flange bolts



48 Short flange bolts



60 Flange nuts



TOOLS AND SUPPLIES REQUIRED

Ratchet

Clip remover

13 mm Socket

13 mm Combination wrench

Extension

Blanket

Torque wrench

INSTALLATION

Customer Information: The information in this installation instruction is intended for use only by skilled technicians who have the proper tools, equipment, and training to correctly and safely add equipment to your vehicle. These procedures should not be attempted by "do-it-yourselfers."

NOTE:

- Thoroughly clean the bottom of the body from the rear of the front wheels up to the front of the rear wheels.
- Be careful not to damage the body paint finish. To prevent damage, place a blanket under the running board during the installation.
- These instructions show the left side running board being installed; the same procedure applies to installing the right running board.

1. Assemble two front bracket assemblies using brackets "A," "B," and "C" along with 8 short flange bolts and 8 flange nuts. Be sure to use the outboard holes in bracket "B." Leave the nuts and bolts loose at this time.

Front Bracket Assembly:

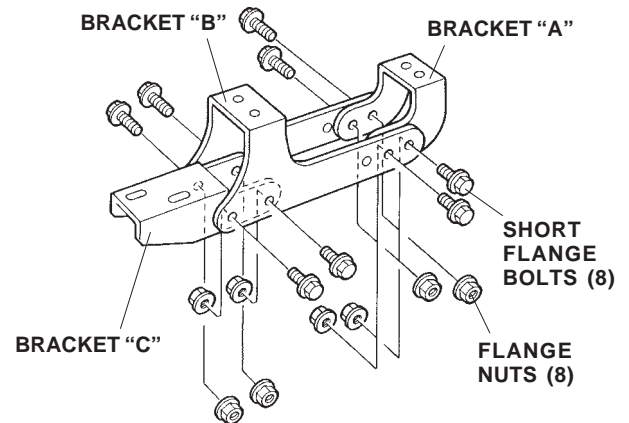

2. Assemble four center and rear bracket assemblies using brackets "A," "B," and "C" along with 8 short flange bolts and 8 flange nuts. Be sure to use the inboard holes in bracket "B." Leave the nuts and bolts loose at this time.

Center and Rear Bracket Assembly:

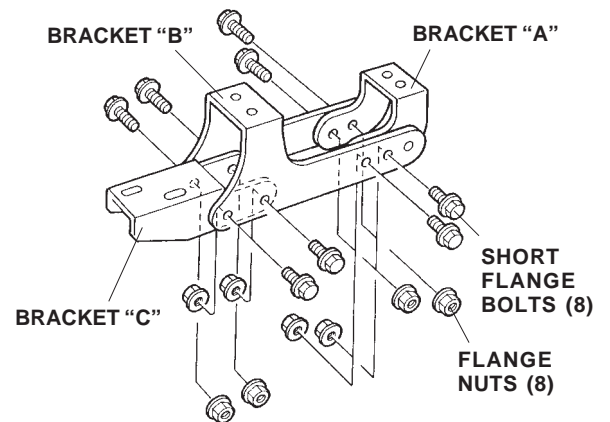

- Remove the six clips from the bottom of the body. Push in on the center of the clip, and remove it using a clip remover tool.

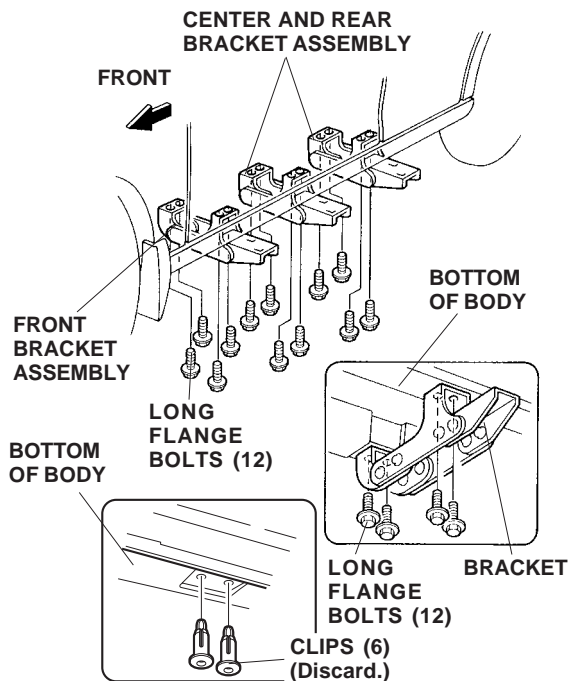

- On the left side of the vehicle, install one bracket assembly at the front, one at the center, and one at the rear along the body using 12 long flange bolts. Thread the long flange bolts in about 3 or 4 threads.
- Set the running board on the brackets with the flange bolts through the holes in the brackets. Install the six flange nuts on the ends of the bolts, but don't tighten them yet.

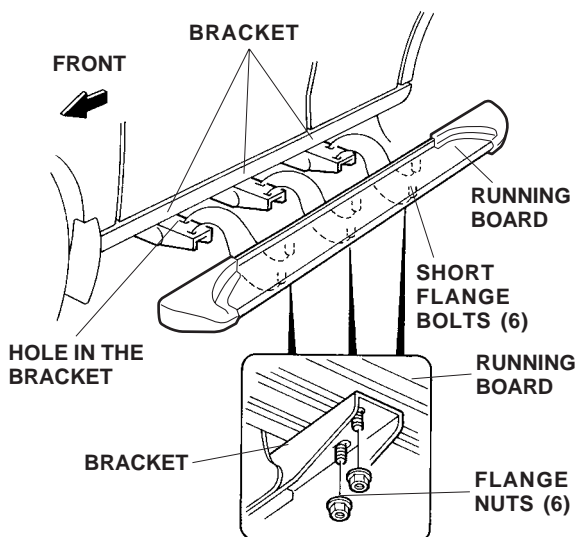

- Align the rear of the running board with the end of the inner fender, then tighten the long flange bolts you installed in step 4. Torque the long flange bolts to 27 N·m (20 lb-ft).

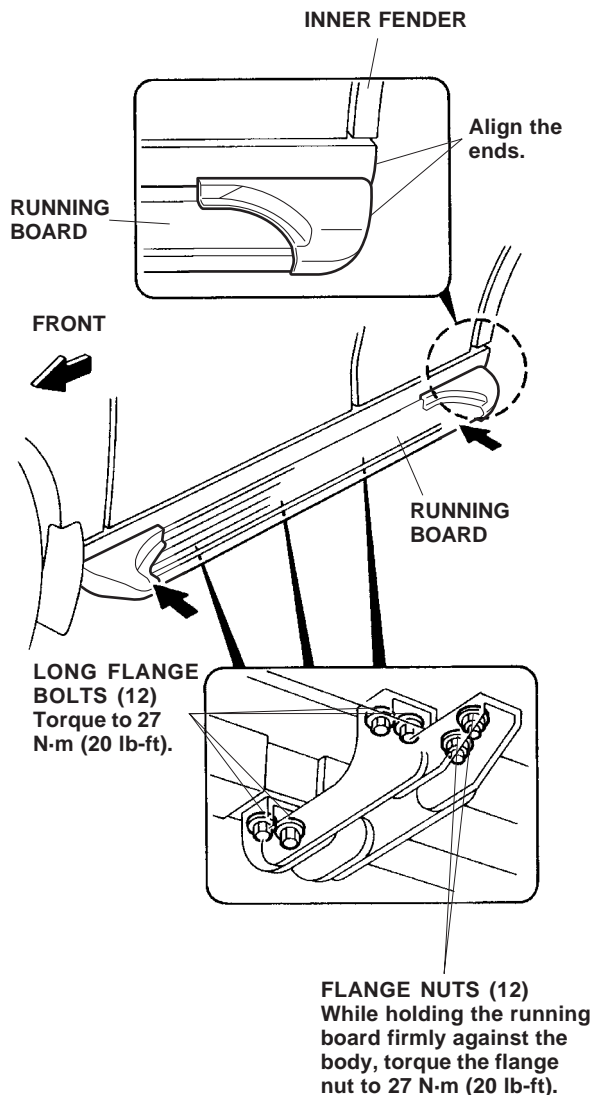

- Torque the short flange bolts you installed in steps 1 and 2 to 27 N·m (20 lb-ft).
- While holding the running board firmly against the body, torque the flange nuts to 27 N·m (20 lb-ft).
- Repeat steps 3 through 8 to install the running board on the right side of the vehicle.