

# INSTALLATION INSTRUCTIONS

Accessory	Application	Publications No.
<b>CD CHANGER ATTACHMENT</b>	<b>2003 PILOT</b>	<b>All 23607</b>
		Issue Date <b>MAY 2002</b>

## PARTS LIST

**CD Changer Attachment Kit (sold separately):  
P/N 08B26-S9V-100**

Right base bracket

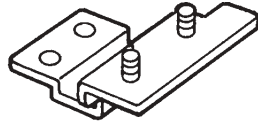

Left base bracket

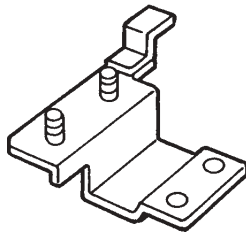

Right changer bracket

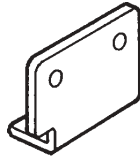

Left changer bracket

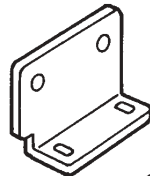

BUS Cable

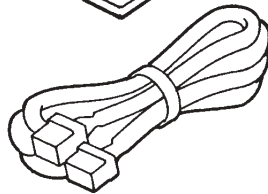

4 Flange bolts, 6 x 12 mm



4 Flange nuts



2 EPT seals (Black)

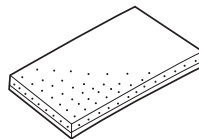

2 Cushion tapes (Gray)

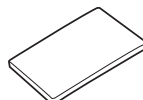

8 Wire ties

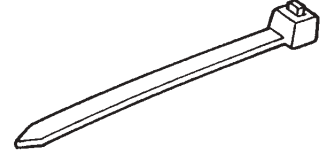

4 Washer-screws, 4 x 8 mm



2 Wire clips

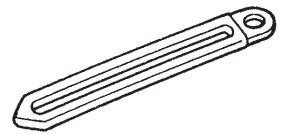

**CD Changer (sold separately):  
P/N 08A26-1B1-100**

CD changer

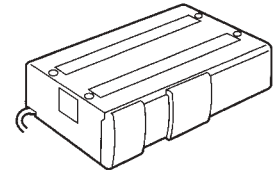

4 Washer-screws, 4 x 6 mm  
(Not used)



Adhesive seal sheet

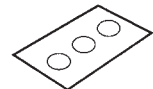

Locking covers

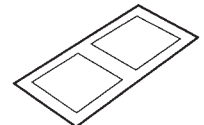

CD magazine

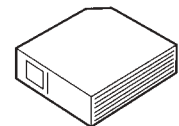

Owner's Manual



Small wire tie  
(Not used)



## TOOLS AND SUPPLIES REQUIRED

Flat-tip screwdriver  
Phillips screwdriver  
Shop towel  
Diagonal cutters  
10 mm Combination wrenches  
Isopropyl alcohol  
Utility knife

## INSTALLATION

**Customer Information:** The information in this installation instruction is intended for use only by skilled technicians who have the proper tools, equipment, and training to correctly and safely add equipment to your vehicle. These procedures should not be attempted by "do-it-yourselfers."

1. Make sure you have the anti-theft code for the radio, then write down the frequencies for the preset buttons.
2. Disconnect the negative cable from the battery.
3. Remove the audio unit.

### Without Navigation Unit:

- Using a flat-tip screwdriver wrapped with a shop towel, gently pry out on the audio panel to remove the five clips. Unplug the connectors and remove the audio panel.

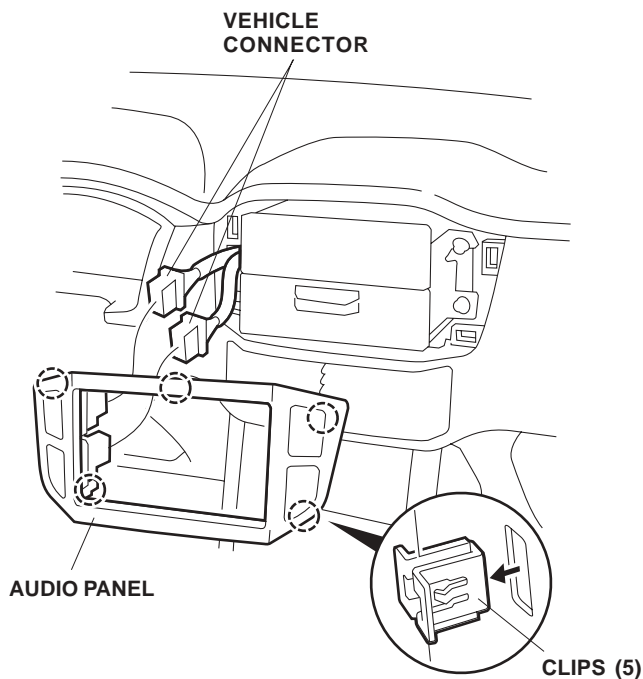

- Remove the four screws that fasten the audio brackets. Pull the audio unit out toward you, unplug the vehicle connector and antenna lead from the rear of the audio unit.

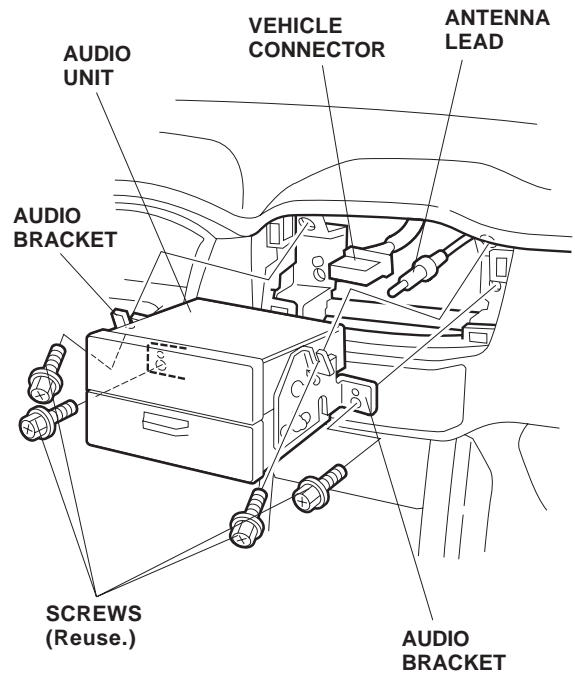

### With Navigation Unit:

- Remove the driver's and passenger's center console trim pieces (three clips each). Take care not to damage the clips.

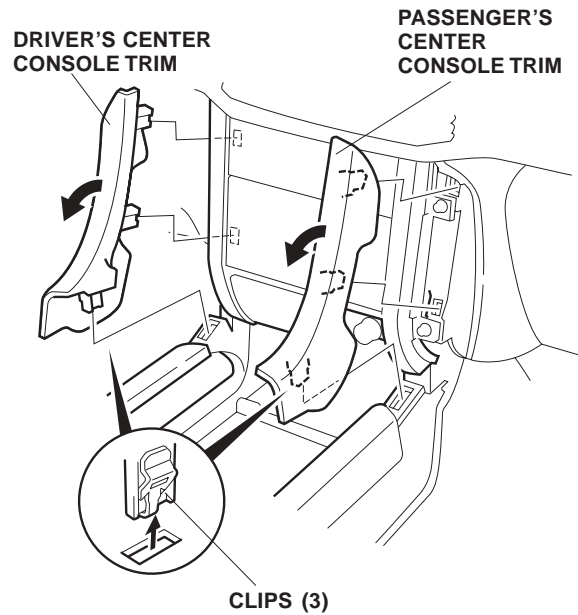

- Remove the center panel (four self-tapping screws, two clips, and unplug the vehicle accessory power outlet).

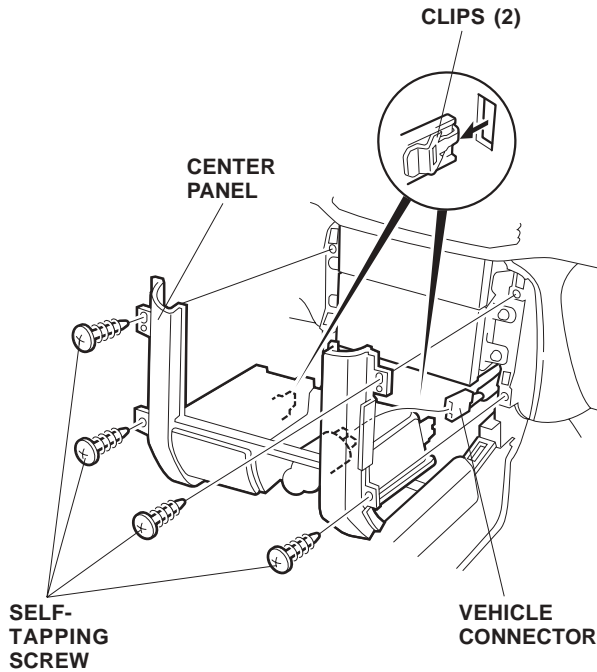

- Remove the four screws that fasten the audio brackets. Pull the audio unit/heater control unit out toward you, unplug the vehicle connectors and antenna lead.

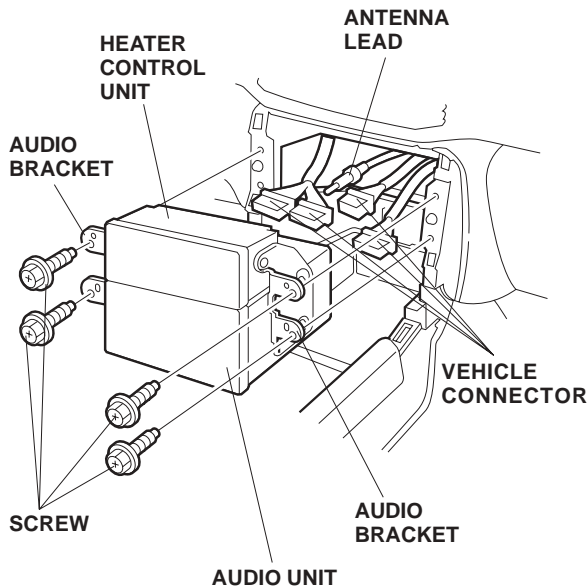

- On the driver's side of the vehicle, gently pull the center console lower cover out toward you to release the seven clips and remove the center console lower cover. Take care not to damage the clips.

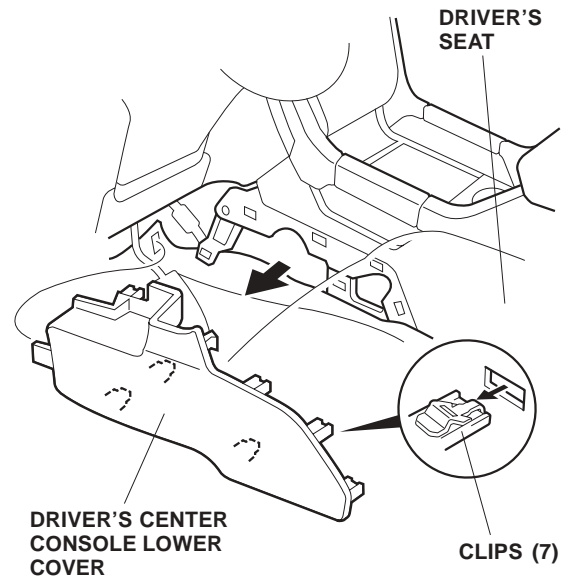

- Remove the driver's seat front cover by pulling it toward you. Take care not to damage the clips.

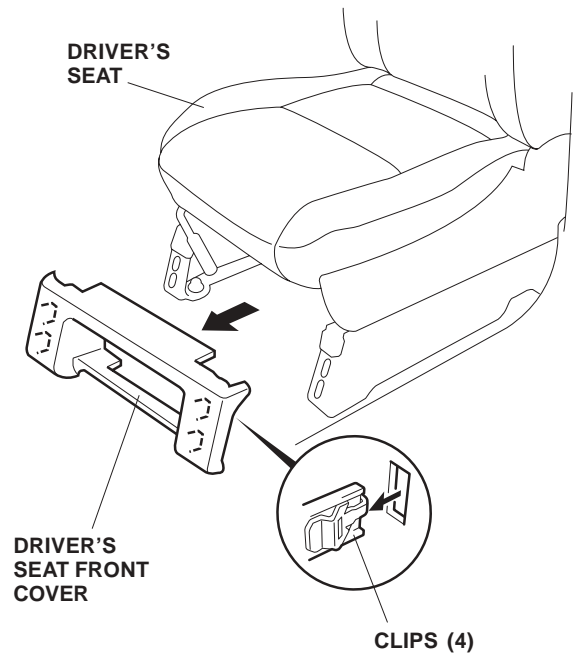

## Routing the BUS cable

6. Route the BUS cable.

### Without Navigation Unit:

- Route the BUS cable from the dashboard opening to the driver's floor. Pull out the end of BUS cable 30 mm from the end of the vehicle 20-pin connector, and secure the BUS cable to the vehicle harness and frame with three wire ties.

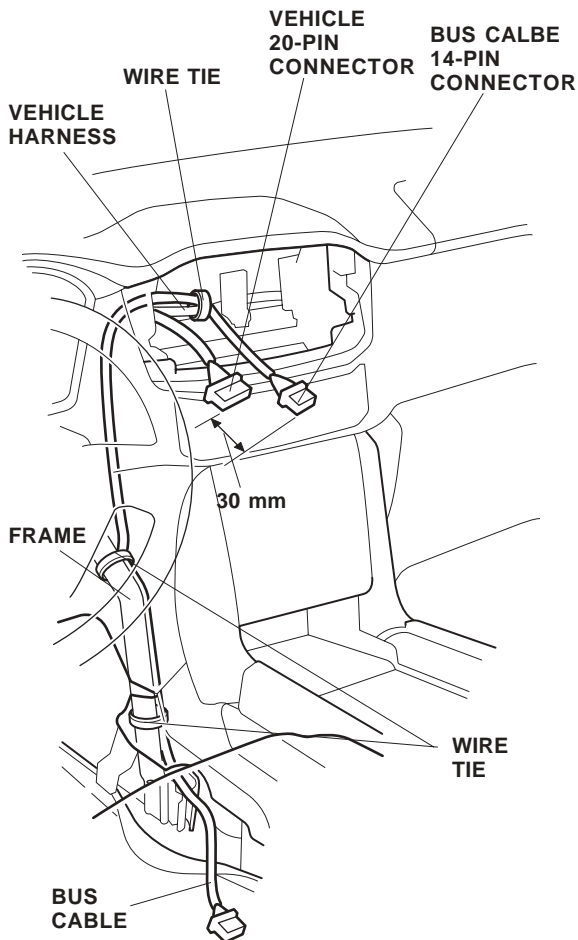

### With Navigation Unit:

- Route the BUS cable from the dashboard opening to the driver's floor. Pull out the end of BUS cable 30 mm from the end of the vehicle 20-pin connector, and secure the BUS cable to the vehicle harness with wire ties.
- Cut the EPT seal in half. Attach 1/2 of the EPT seal on the edge of vehicle body to protect the BUS cable. Before attaching the tape, wipe the surface with isopropyl alcohol.
- Secure the BUS cable on the vehicle frame with two wire ties.

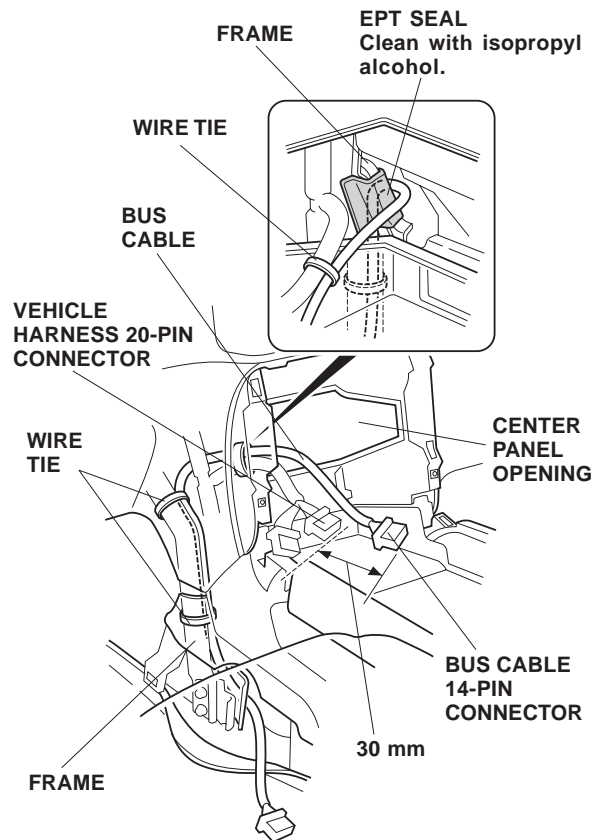

- Using 1/2 of an EPT seal attach it to the frame at the location shown. Measure 450 mm from the end of the BUS cable to the frame, then bundle up the excess cable and secure it to the vehicle with three wire ties.

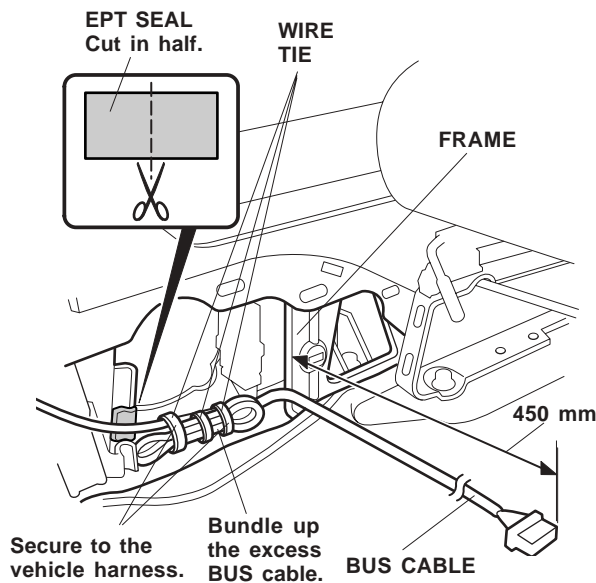

- Attach 1/2 of an EPT seal to the edge of the frame in the area shown.

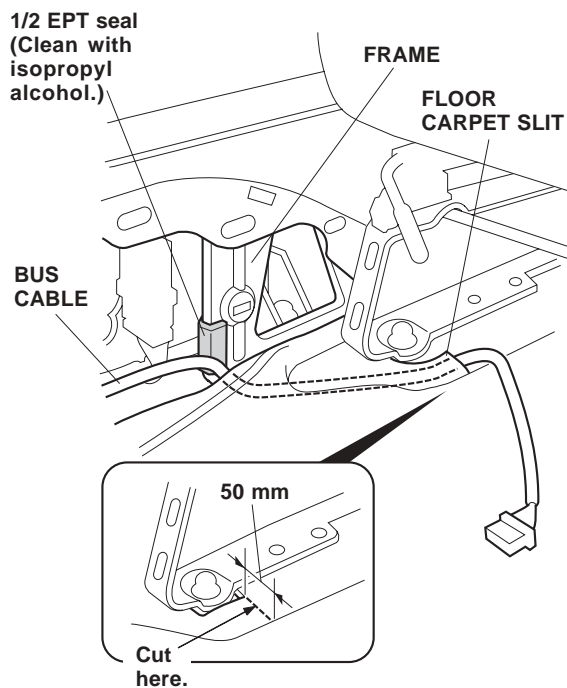

- Near the edge of the driver's seat raiser make a 50 mm slit in the floor carpet with a utility knife. Route the BUS cable under the floor carpet and out the slit near the seat raiser.

- Install the right and left base brackets to the driver's seat raisers using two 6 x 12 mm flange bolts for each bracket. Do not tighten the bolts yet.

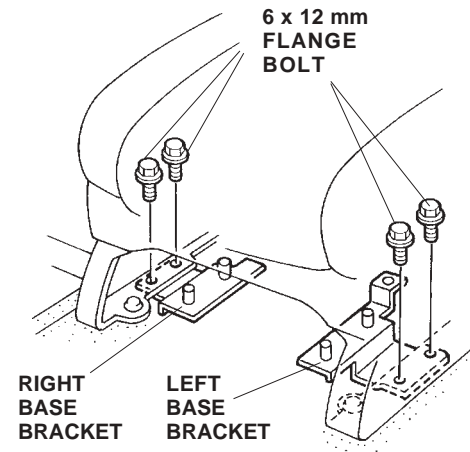

### Installing the CD Changer

- Carefully unpack the CD changer. Remove the three shipping clips, and discard the shipping cover. Install an adhesive seal (included with the CD changer kit) over each of the three clips holes. Save the shipping clips for your customer in the event the unit needs to be serviced.

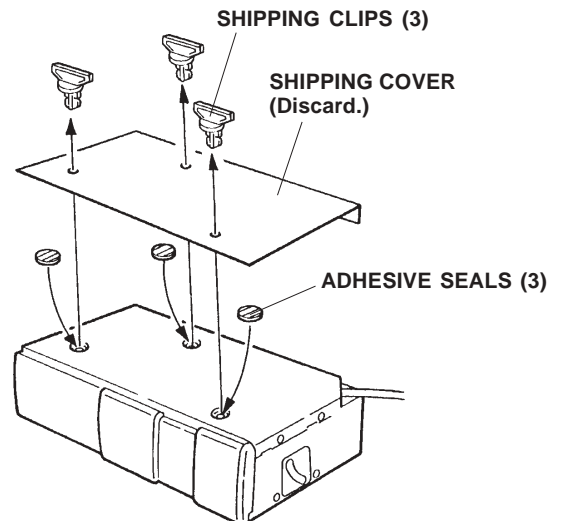

12. Visually check the position of the spring adjusting pin on both sides of the CD changer. If the spring adjusting pins are not in the horizontal (H) position, move the pins to the horizontal (H) position by sliding them up with your fingers.

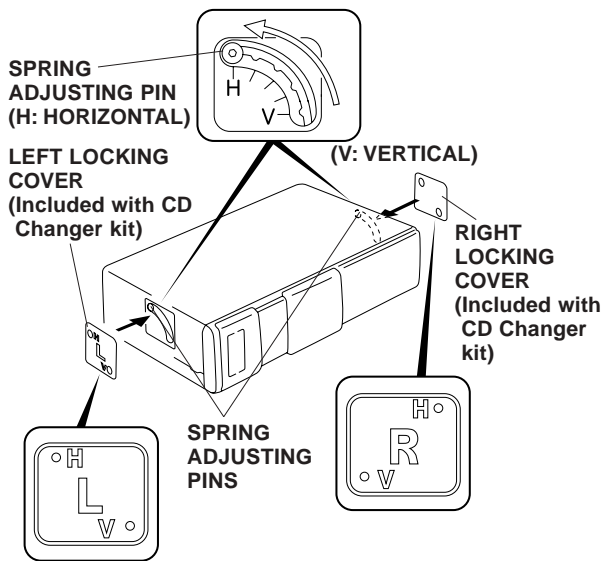

13. Remove the adhesive backing from the "L" and "R" locking covers, and attach them to the sides of the CD changer. Align the diagonally opposite holes with the H and V positions.
14. Install the right changer bracket to the CD changer using two 4 x 8 mm washer-screws, and the two wire clips. Install the left changer bracket to the CD changer using two 4 x 8 mm washer-screws.

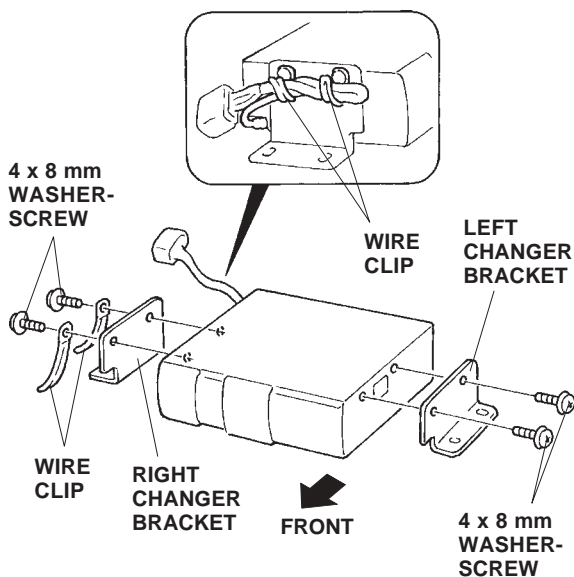

15. Attach one cushion tape to the rear of the CD changer leaving half of the cushion tape extended past the CD changer. Using scissors, cut the cushion at the end of the CD changer. Fold the ends down and around the end of the CD changer.

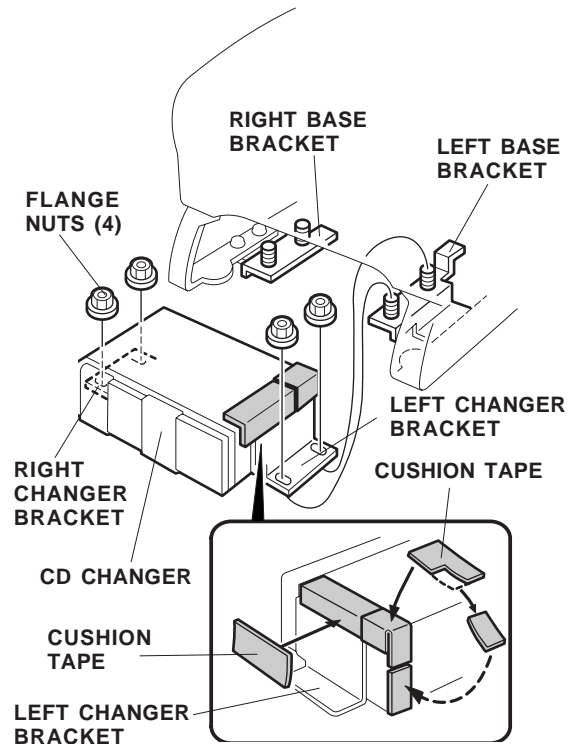

16. Attach the cushion tape to the top of the left changer bracket align the cushion tape already attached. Fold the cushion tape around the CD changer.
17. Insert the studs of the left and right base brackets into the holes in the left and right changer brackets, then install the four flange nuts on the end of each stud. Tighten the four flange nuts and four bracket bolts in step 10 on the bracket plates.

- Plug the BUS cable connector into the CD changer connector. Bundle up any excess BUS cable and attach it to the CD changer bracket with the two wire clips installed in step 14.

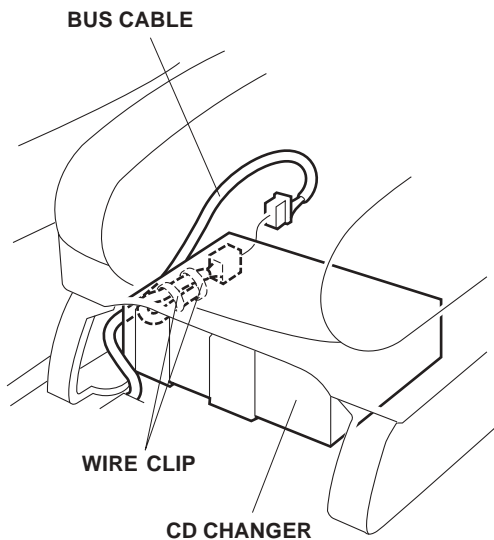

- At the dashboard area, plug the BUS cable 14-pin connector, the vehicle connectors, and the antenna lead into the rear of the audio unit.

**With Pocket:**

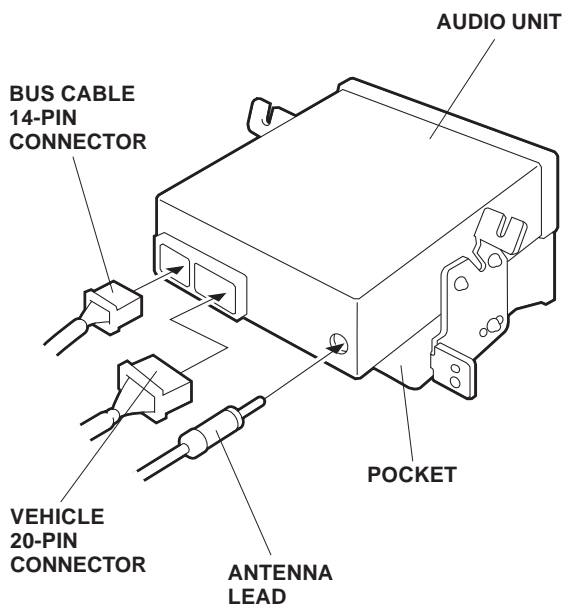

**With Cassette Player:**

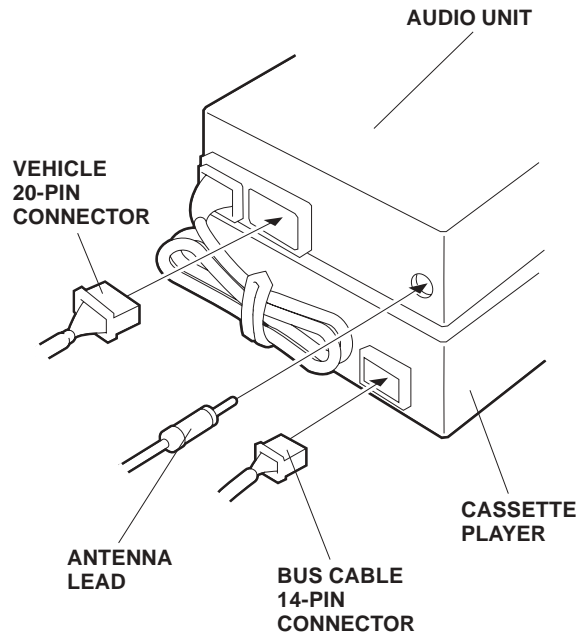

**With CD/Cassette Tuner:  
(With Navigation Unit)**

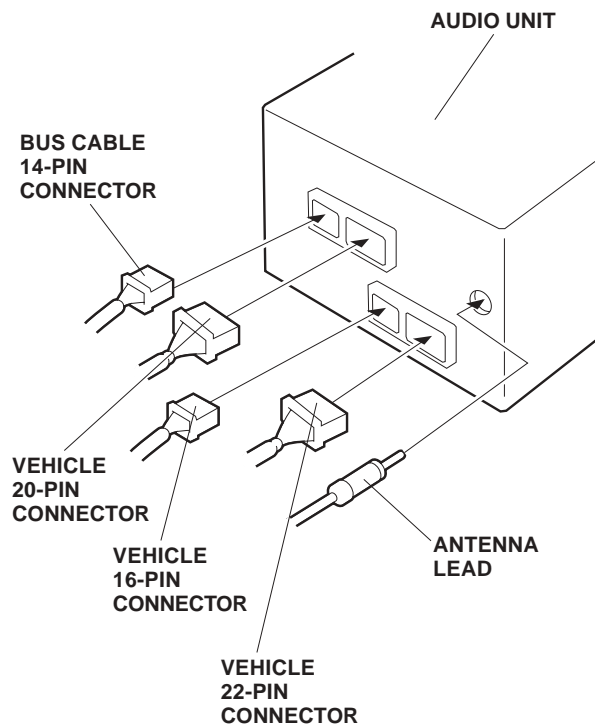



- Slide the audio unit into the center panel opening, and reinstall the four screws.

**Without Navigation Unit:**

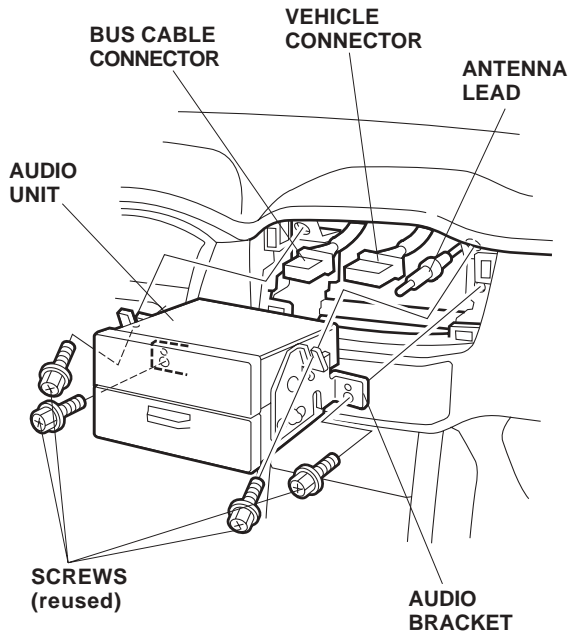

**With Navigation Unit:**

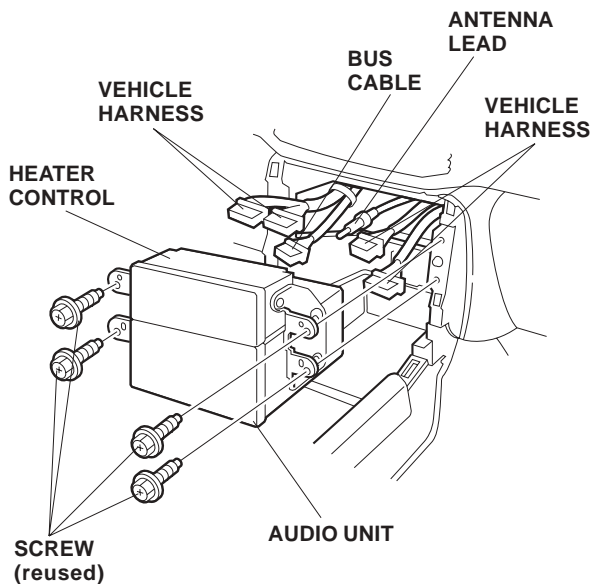

- Check that all wire harnesses are routed properly and all connectors are plugged in.
- Reinstall all removed parts.
- Place shipping clips in a plastic bag and put the bag in the glove box.
- Reconnect the negative cable to the battery.
- Enter the customer's radio anti-theft code, and reset the radio station presets.

**NOTE:** Whenever the battery is disconnected, the driver's window AUTO function is disabled.

- Start the engine. Push down on the driver's window switch until the window is fully open.
- Pull up on the driver's window switch to close the window completely, then hold the switch for two seconds.
- Test the AUTO window function.
- Do the idle learn procedure.
  - Make sure all electrical items are turned off.
  - Start the engine. Hold the engine speed at 3,000 rpm with no load (in Park or Neutral) until the radiator fan comes on.
  - Let the engine idle for about 5 minutes with the throttle fully closed and with all electrical items off.

**NOTE:** If the radiator fan comes on during this step, the time when it is operating must not be included in the 5 minutes.