



INSTALLATION INSTRUCTIONS

Accessory

**XM RADIO SYSTEM
(EXCEPT LX)**

Application

2005 ODYSSEY

Publications No.

All 27373

Issue Date

SEP 2004

PARTS LIST

**XM Radio Attachment (sold separately):
P/N 08B15-SHJ-100**

2 Tuner brackets

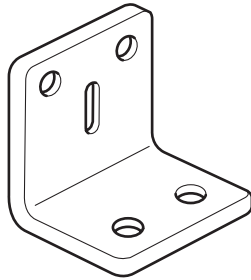

BUS cable

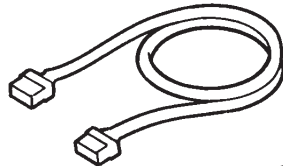

14 Wire ties

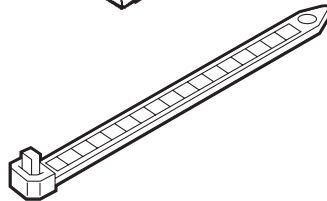

Double-sided tape

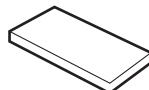

5 Pan screws, 5 x 8 mm



5 Plain washer, 5 mm



4 Flange bolts, 6 x 12 mm

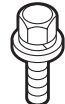

3 EPT seals

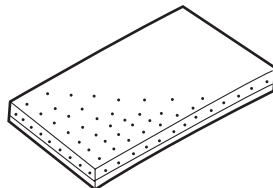

2 Cushion tape

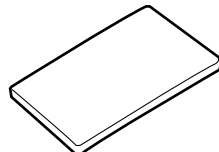

**XM Antenna (sold separately):
P/N 08A15-EX5-100B**

Antenna

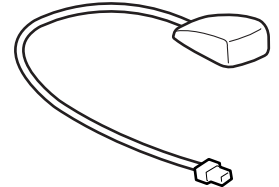

Splitter

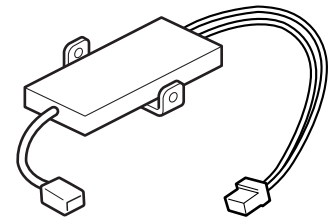

Connector clip



**Unit kit (sold separately):
P/N 08A15-EX5-000**

XM Tuner

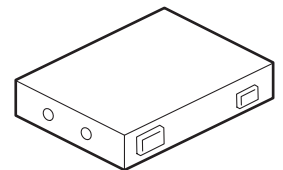

TOOL AND SUPPLIES REQUIRED

#2 Phillips screwdriver

Flat-tip screwdriver

Tape measure

Shop towel

Ratchet

6 mm, 8 mm, and 10 mm Sockets

6 mm, 8 mm, and 10 mm Combination wrenches

Isopropyl alcohol

Illustration of the XM Radio System Installed on the vehicle

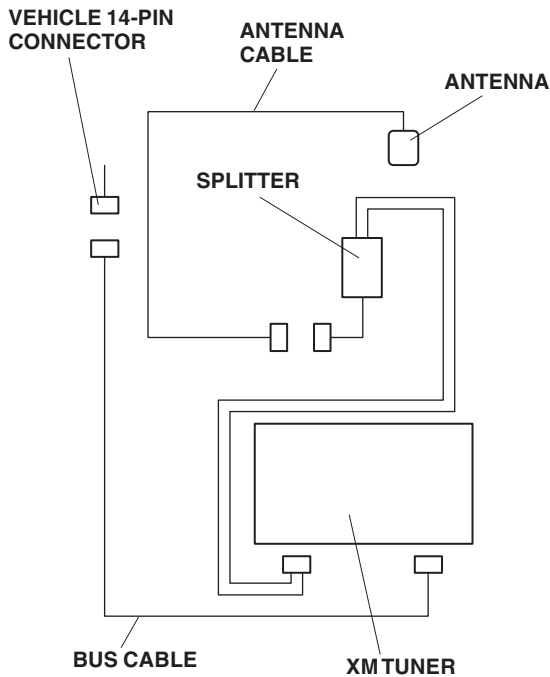
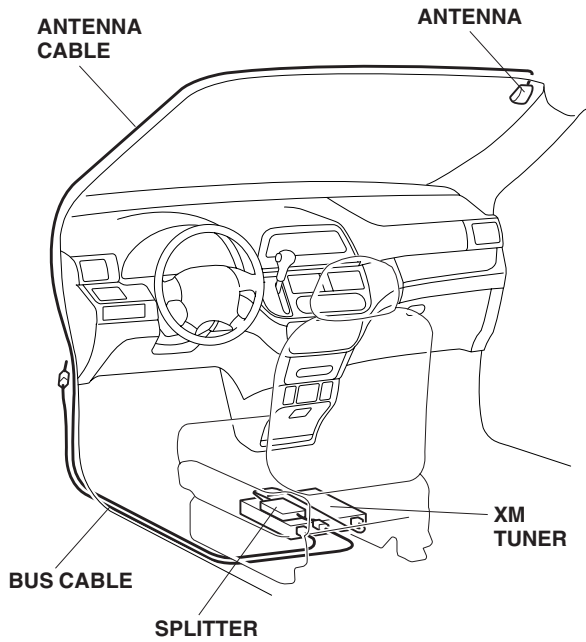

INSTALLATION

Customer Information: The information in this installation instruction is intended for use only by skilled technicians who have the proper tools, equipment, and training to correctly and safely add equipment to your vehicle. These procedures should not be attempted by "do-it-yourselfers."

1. Make sure you have the anti-theft code for the radio, then write down the radio station presets.
2. Disconnect the negative cable from the battery.
3. Open the sunglasses holder, remove the two 5 mm bolts. Insert a flat-tip screwdriver between the lens and roof console housing, and gently pry out the map light lens covers. Remove the two ground bolts. Pull out the roof console from the headliner.

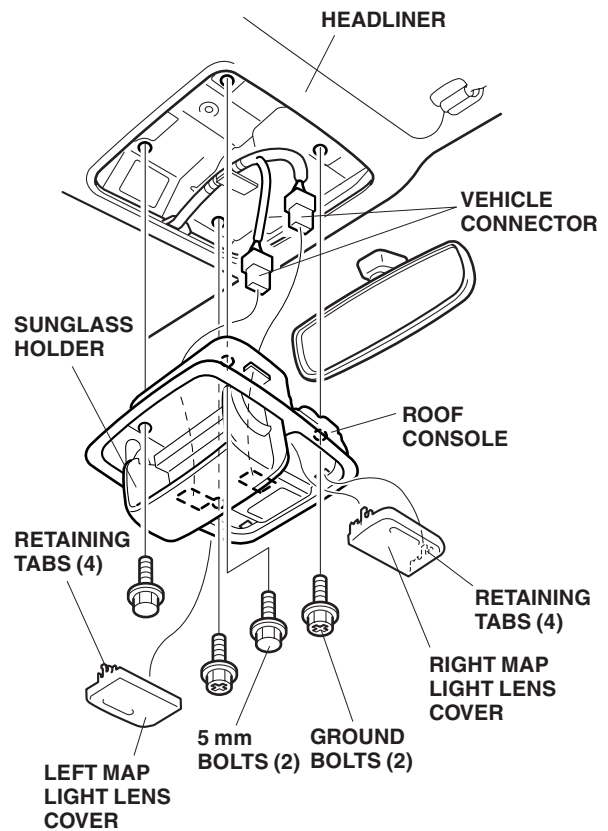

4. Disconnect the two vehicle connectors and remove the roof console.

- Remove the cover from the left sunvisor.

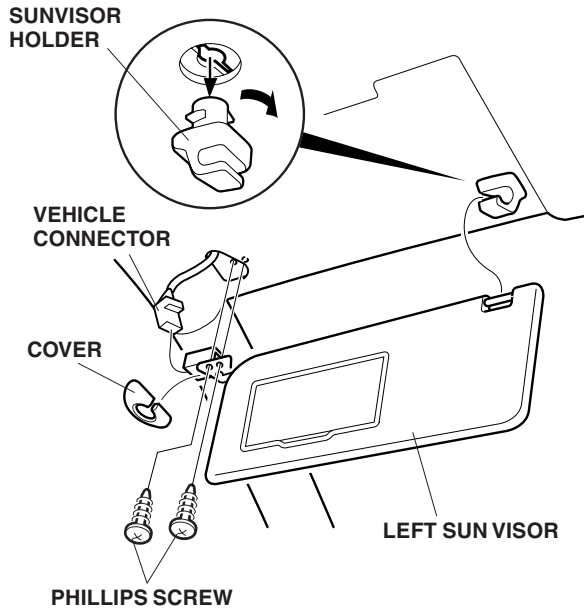

- Remove the two phillips screws, pull out the left sunvisor, disconnect the vehicle connector, and remove the sunvisor.
- Repeat steps 5 and 6 to remove the right sunvisor.
- Remove the right and left sunvisor holders. With a small flat-tip screwdriver, push the clip, and turn the holders 90°, then pull them out.
- Remove the door opening trim from around the left front "A" pillar trim. Remove the left front "A" pillar (two clips).

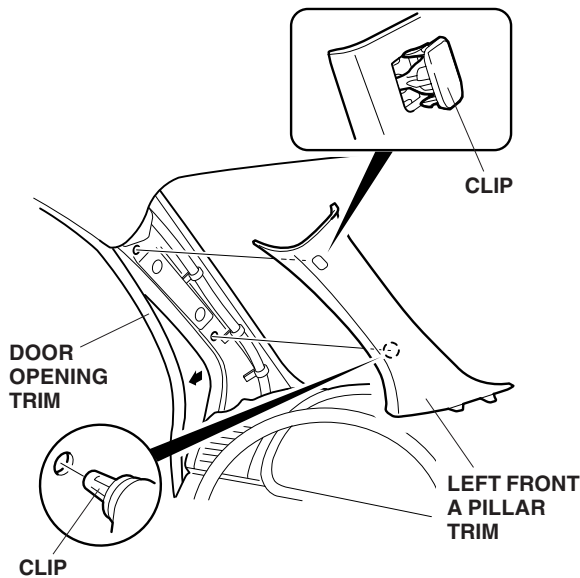

- Remove the driver's side instrument panel (six clips and three retaining tabs).

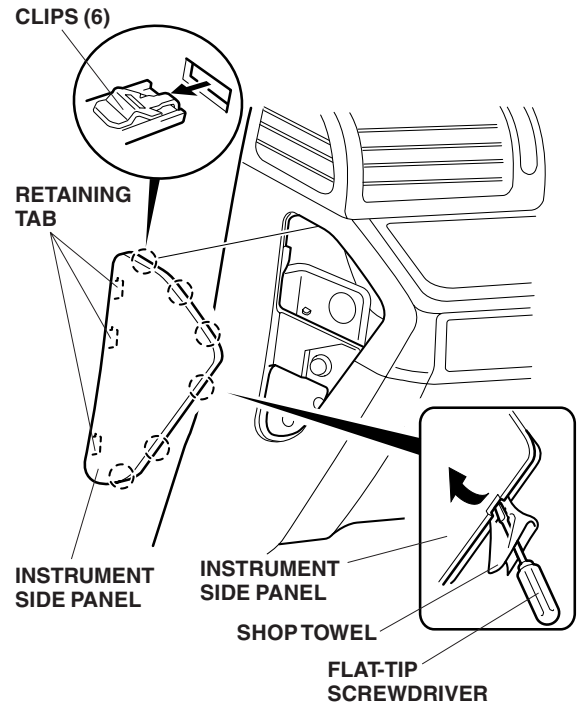

- Remove the left front door sill trim (three clips).

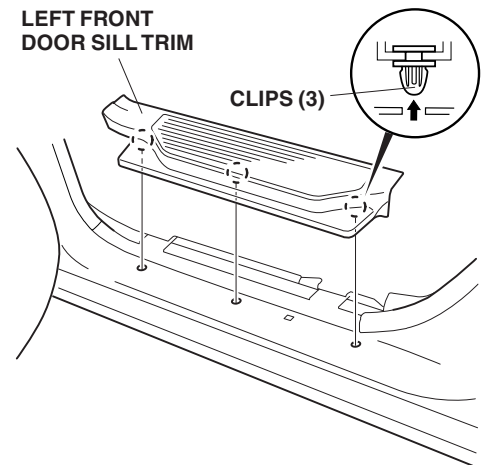

12. Pull out the door opening trim at the left kick panel. Remove the left kick panel (three clips).

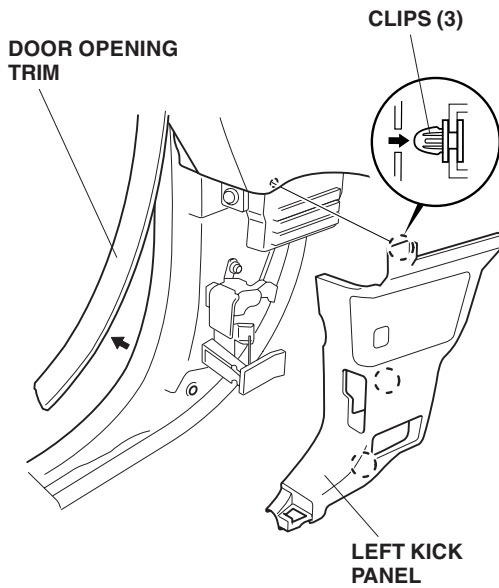

13. Remove the driver's seat rear rail cover (four clips).

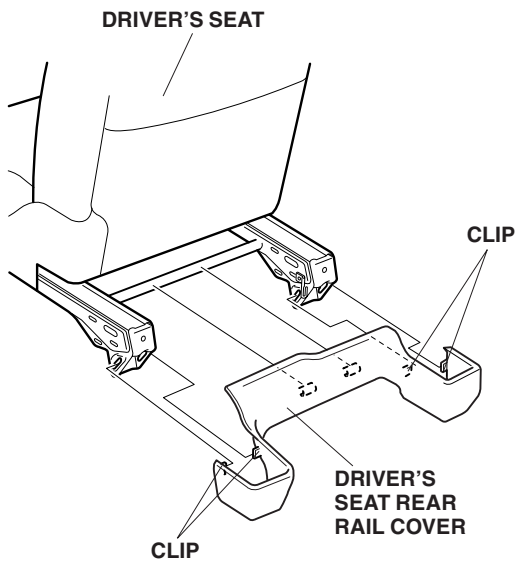

Installing the Antenna

14. Using scissors, cut three EPT sealers in half. Attach the six pieces of cut EPT sealers around the antenna harness at the locations shown.

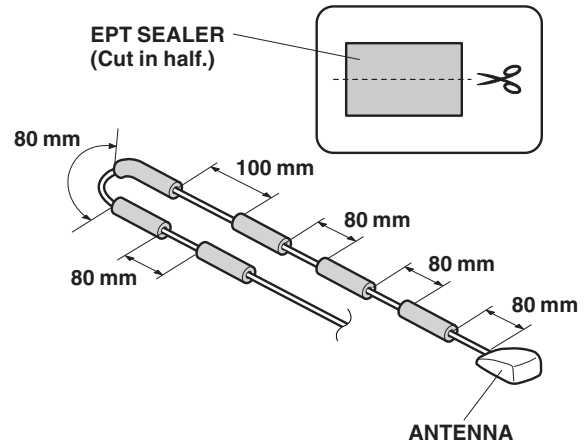

15. Using the isopropyl alcohol, clean the areas where the antenna will attach. Remove the adhesive backing from the antenna and attach the antenna to the front window at the locations shown. Install the antenna by applying sufficient pressure.

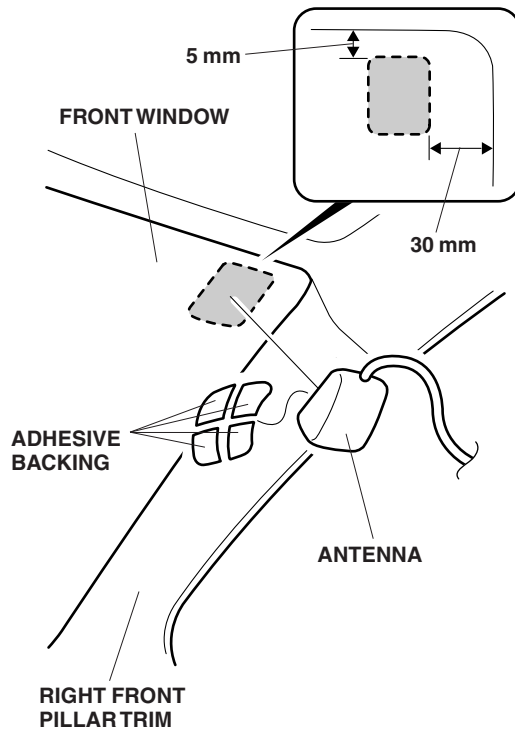

16. Route the antenna cable so that it routes inside the headliner.

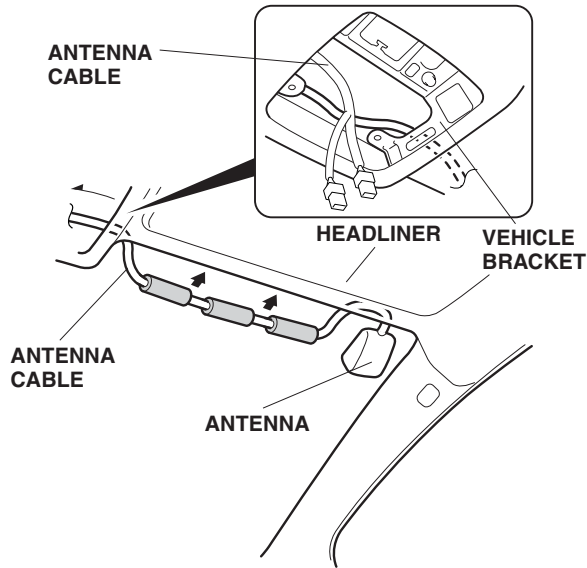

17. Embed the antenna cable in the headliner and secure it with one wire tie to the vehicle harness.

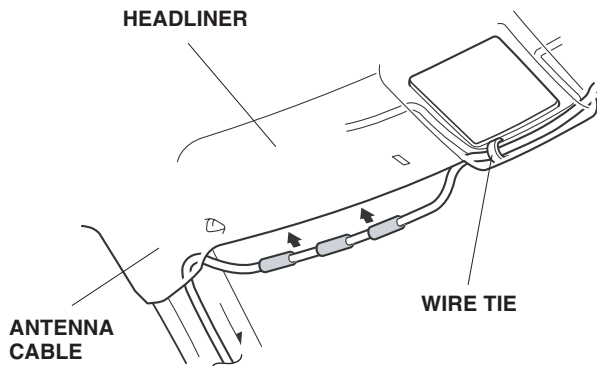

18. Route the antenna cable along the left front "A" pillar. Secure the antenna cable to the vehicle harness with four wire ties.

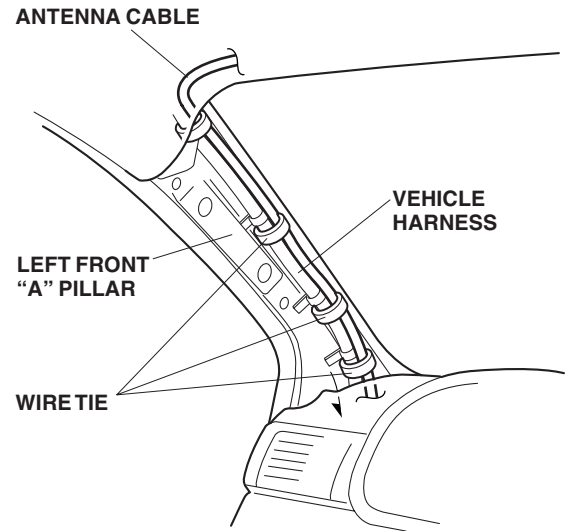

19. Route the antenna cable along the vehicle harness towards the driver's under-dash fuse box. Secure the antenna cable with one wire tie in the area shown.

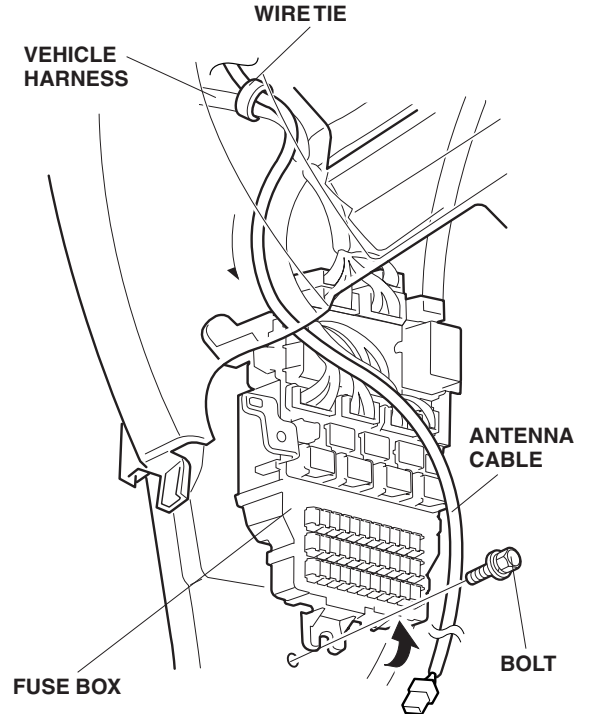

20. Remove the bottom bolt from the driver's under-dash fuse box.

- Turn up the carpet. Route the antenna cable under the carpet and next to the vehicle harness.

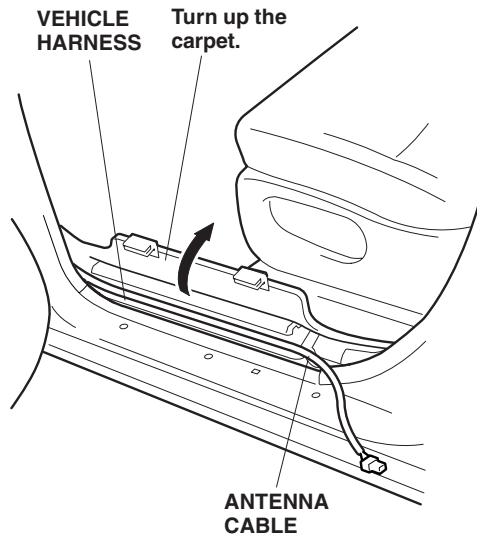

- Turn up the carpet. Continue routing the antenna cable underneath the driver seat, and out the carpet opening.

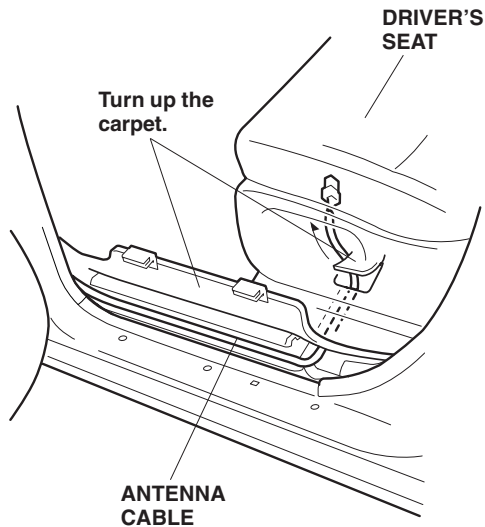

Routing the BUS Cable

- Under the dash, locate the vehicle 14-pin connector blue-taped to the vehicle harness. Remove the blue-tape to free the connector.

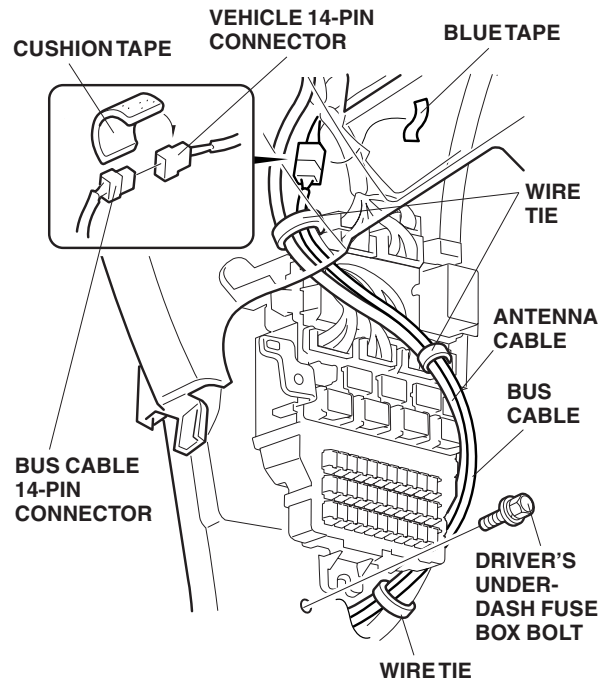

- Get the bus cable. Plug one end of the bus cable into the 14-pin connector you just freed.
- Wrap a cushion tape around the connectors you connected in step 24.
- Route the bus cable and the antenna cable down behind the lower right corner of the driver's under-dash fuse box following the vehicle harness. Secure the bus cable and the antenna cable to the vehicle harness with three wire ties in the area shown. Reinstall the driver's under-dash fuse box bolt.

27. Route the bus cable and the antenna cable along the driver's side sill. Secure the bus cable and antenna cable to the vehicle harness with the three wire ties.

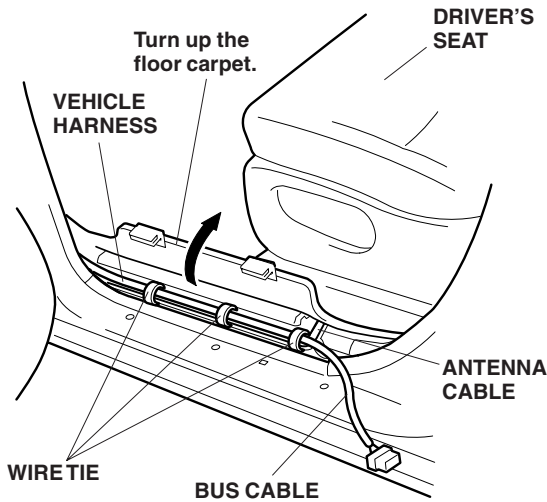

28. Continue routing the BUS cable underneath the driver seat.

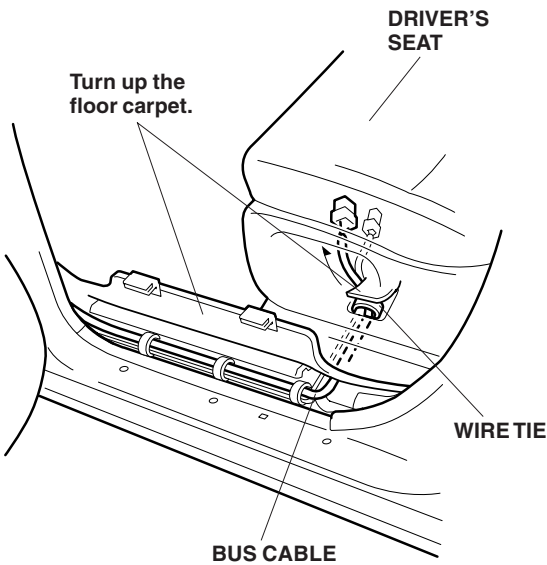

29. Secure the antenna cable and bus cable to the vehicle harness at the carpet opening with one wire tie.

Installing the XM Tuner

30. Attach the tuner brackets to the XM tuner with four 5 x 8 mm pan screws and four 5 mm plain washers.

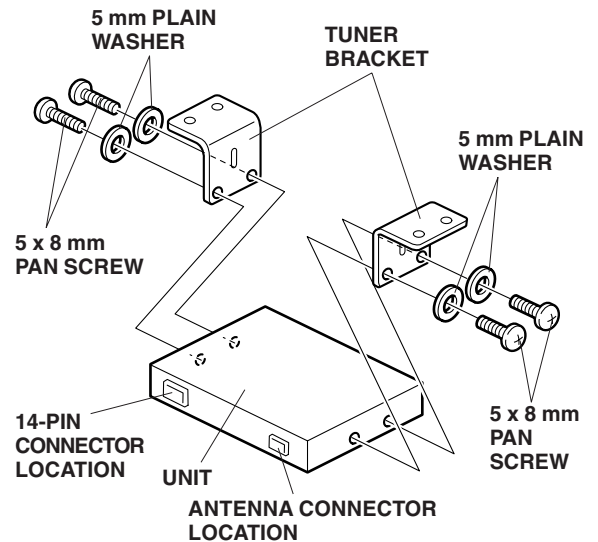

31. Using the isopropyl alcohol, clean the areas where the double-sided tape will attach. Remove the adhesive backing from the double-side tape and attach the double-face tape to the splitter.

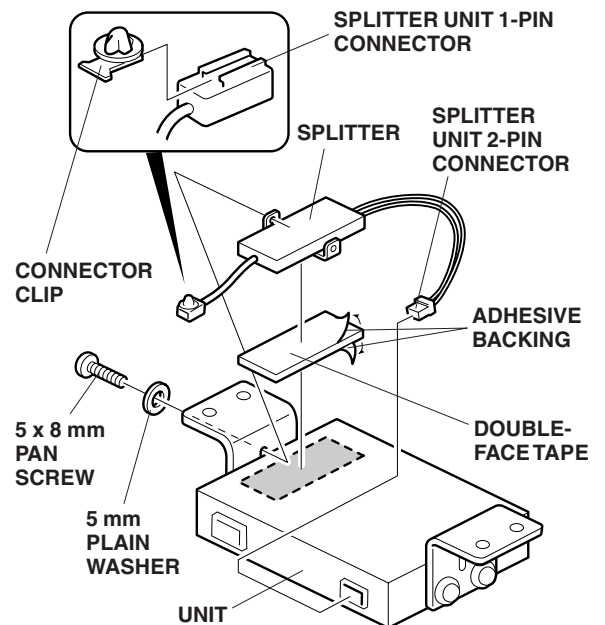

32. Remove the adhesive backing from the other side of the double-sided tape and install the splitter to the XM tuner with one 5 x 8 mm pan screw and one 5 mm plain washer.

33. Secure the splitter 2-pin connector cable to the XM tuner with a cushion tape.

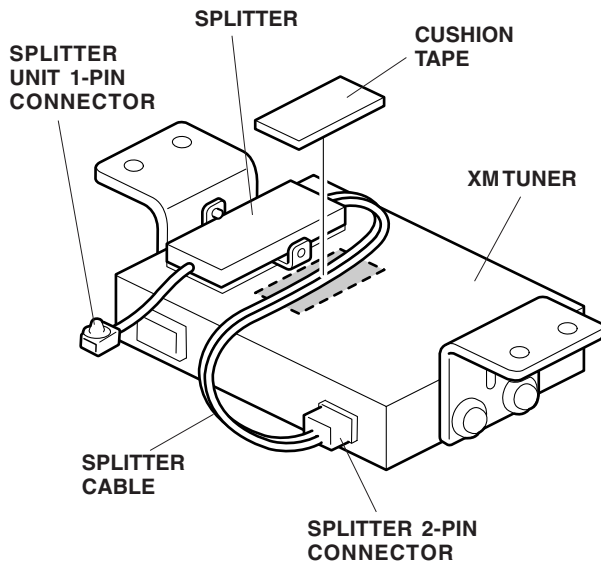

34. Plug the splitter 2-pin connector into the XM tuner.
 35. Install the connector clip on the splitter 1-pin connector.
 36. Install the XM tuner assembly to the bottom of the driver's seat with four 6 x 12 mm flange bolts.

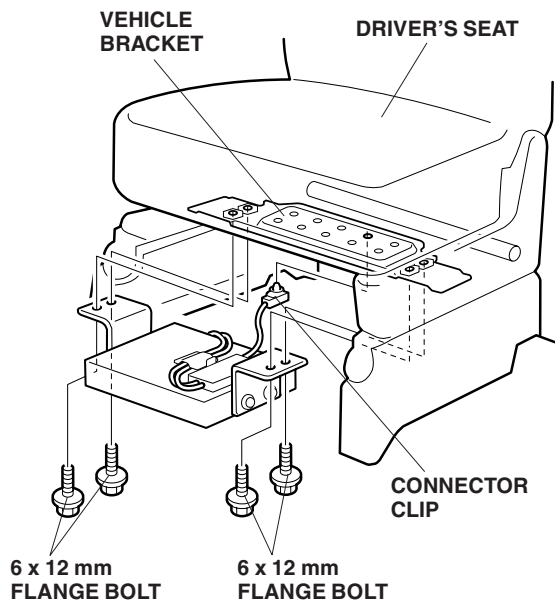

37. Plug the antenna 1-pin connector into the splitter 1-pin connector.

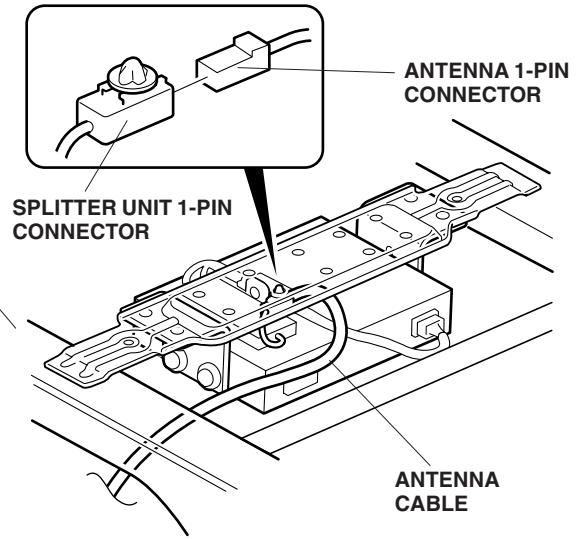

38. Attach the connector clip you installed on the splitter 1-pin connector to the vehicle bracket.
 39. Plug the bus cable 14-pin connector into the XM tuner.

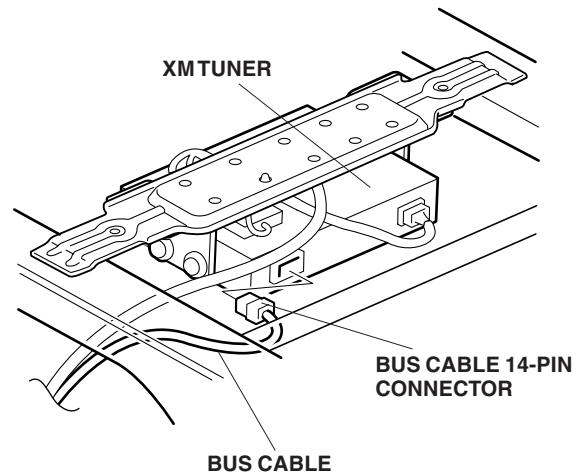

40. Fold the excess length of antenna cable and bus cable and secure the folded cable to the vehicle pipe with two wire ties.

NOTE: Secure the excess length of cables to the front side of the vehicle pipe.

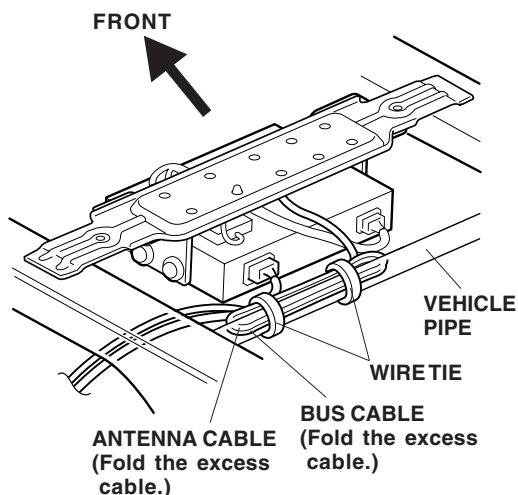

41. Check that all wire harnesses are routed properly and all connectors are plugged in.
42. Reconnect the negative cable to the battery.
43. Enter the customer's radio anti-theft code, and reset the radio stations.
44. Reset the clock.
45. Reinstall all removed parts.

NOTE: Whenever the battery is disconnected, the driver's AUTO function is disabled.

46. Start the engine. Push down on the driver's window switch until the window is fully open, then hold the switch for 2 second or more.
47. Pull up on the driver's window switch to close the window completely, then hold the switch for 2 second or more.
48. Test the AUTO window function.