



INSTALLATION INSTRUCTIONS

Accessory

SURFBOARD ATTACHMENT
P/N 08L05-SCV-100

Application

2005 ODYSSEY

Publications No.

All 27364

Issue Date

SEP 2004

Put this information in the glove box with the vehicle owner's manual.

PARTS LIST

4 Bases

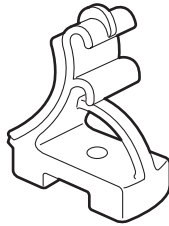

4 Knobs



4 Bolts

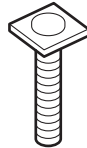

2 Straps

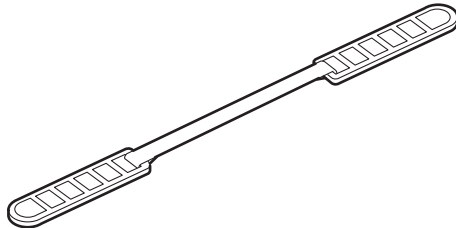

2 Strap protectors

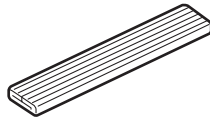

4 Spacers



4 Washers



TOOLS REQUIRED

Phillips screwdriver

INSTALLATION

NOTE: Be careful not to damage the body paint finish.

1. Loosely assemble the knobs, washers, spacers, and bolts with the bases as shown.

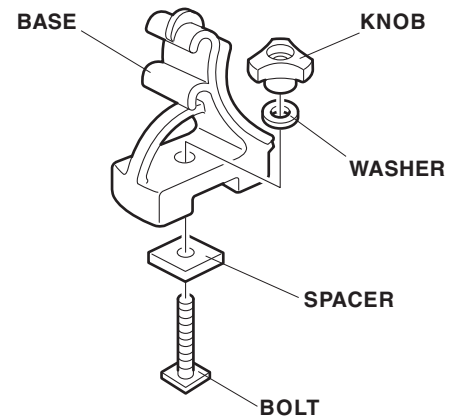

2. Using a flat-tip screwdriver wrapped with a shop towel, pry the cover up at the groove and remove the cover.

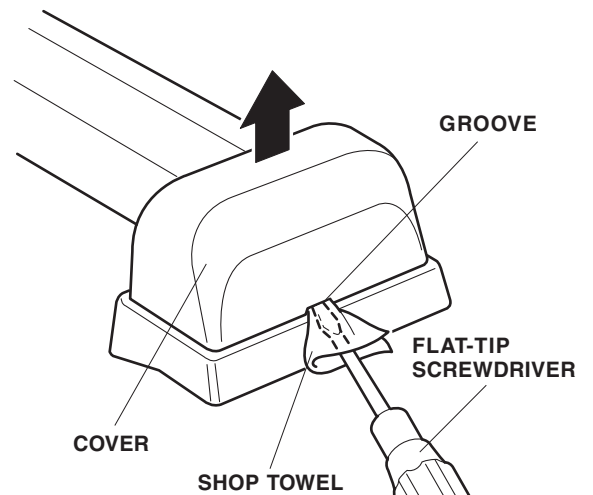

- Remove the rubber moldings from the front and rear roof rack crossbars. Retain the rubber moldings to be reinstalled if the surfboard attachment is removed.

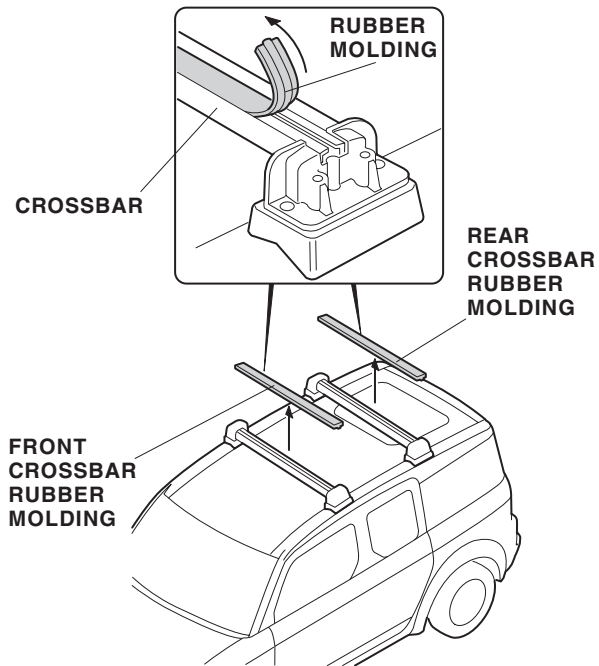

- Insert the bolt head from the surfboard attachment into the channel of the crossbar. Do not tighten the bolt at this time.

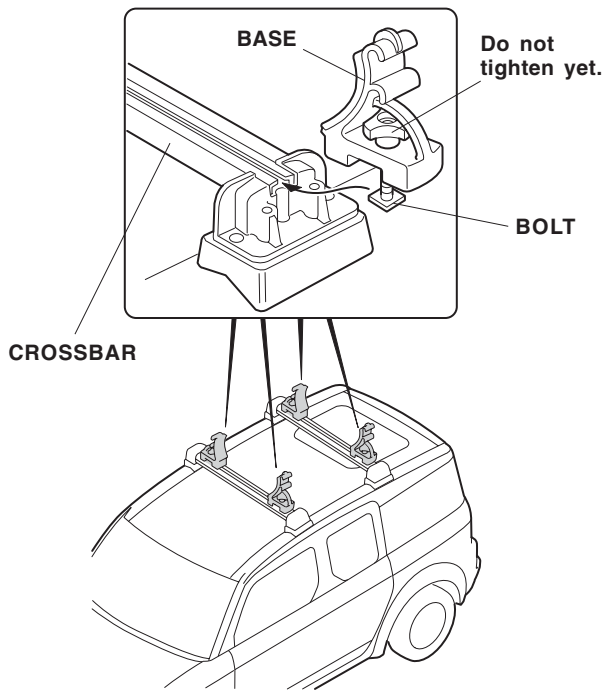

- Attach the strap protectors to the straps.

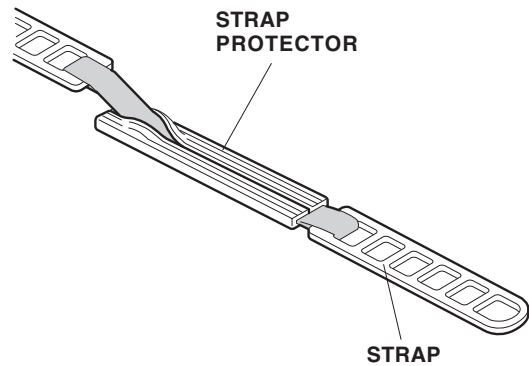

- Tighten the right front base firmly to the crossbar. Mount the surfboard to the base with the nose forward and the fin up. Position the edge of the board so that it sits on the pad of the base. There should be no more than 410 mm (16 in.) of surfboard overhanging from the front crossbar.

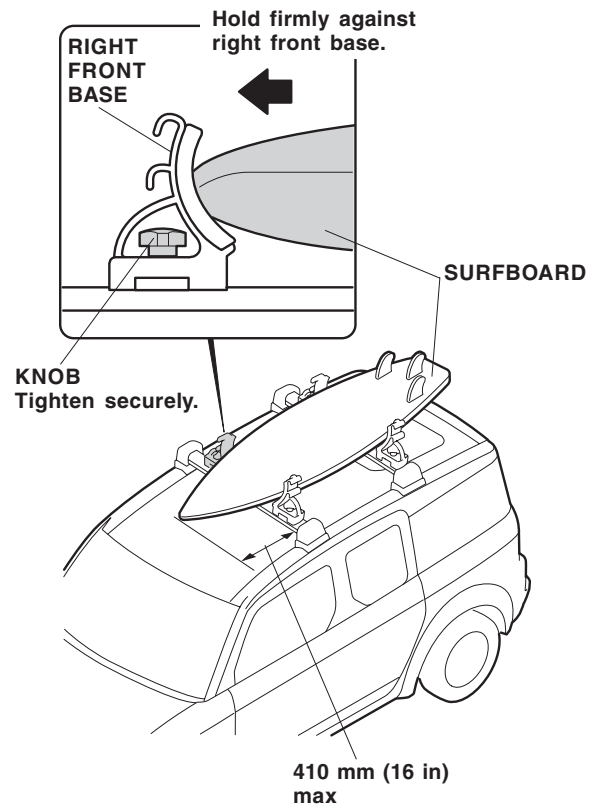

- Position the left front base against the edge of surfboard and tighten firmly. Position the rear bases against the rear of the surfboard firmly and tighten the knob.

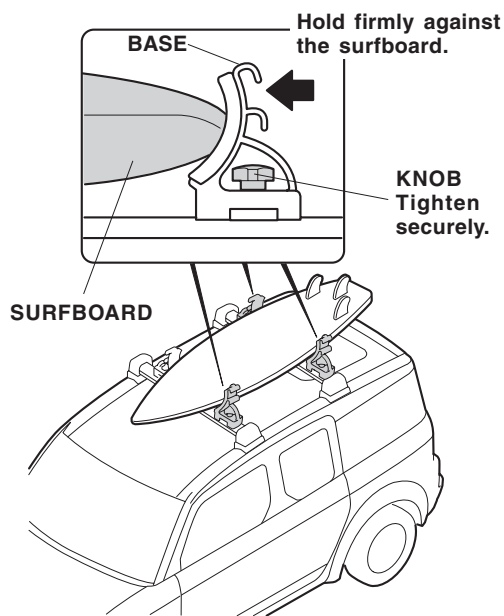

- Fasten the strap tight across the surfboard using the lower hooks on the base.

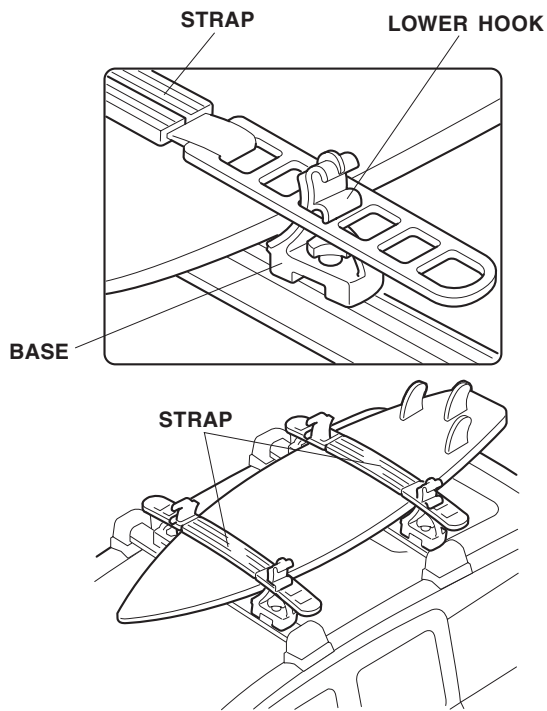

- Recheck that the bases are installed securely, and tighten them if necessary.

- To prevent excess wind noise, cut each rubber molding, and install the cut pieces into the grooves in the crossbars.

