

**INSTALLATION  
INSTRUCTIONS**

Accessory

**FOG LIGHTS**

Application

**2005 ODYSSEY**

Publications No.

**All 27346**

Issue Date

**SEP 2004****PARTS LIST**

Right fog light

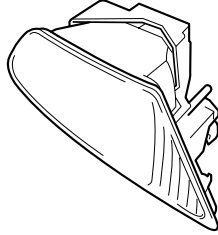

Left fog light

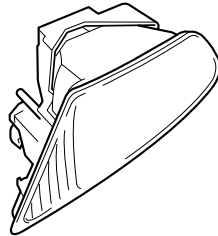

Right bracket

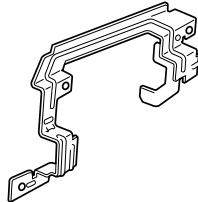

Left bracket

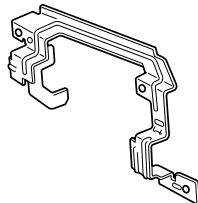

Fog light harness

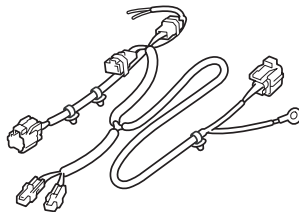

Switch harness

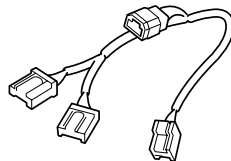

Template

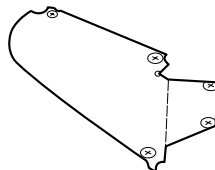
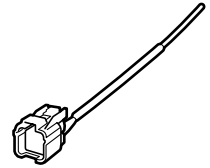
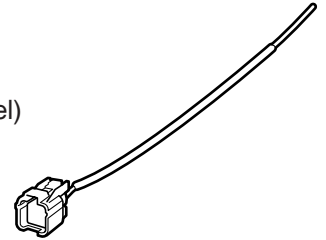
Short sub harness  
(LX model)Long sub harness  
(EX model and Touring model)

Relay bracket

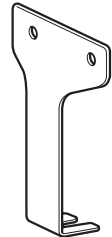

Relay (Gray)

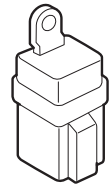

Relay (Black)

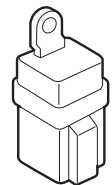

26 Wire ties

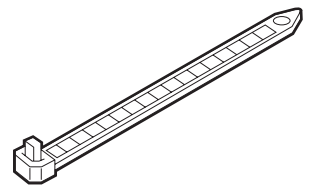

Wire ties with holder

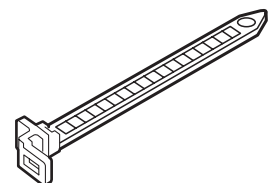

3 Wire ties with clip

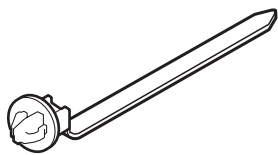

4 Small wire ties

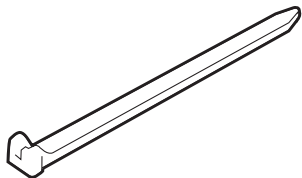

Switch

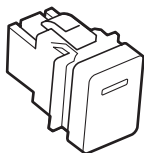

2 Washer-bolts, 6 x 16 mm

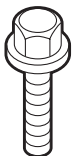

2 Washer-bolts, 5 x 16 mm

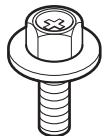

6 Self-tapping screws



Ground bolt

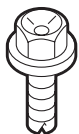

4 Cushion tapes

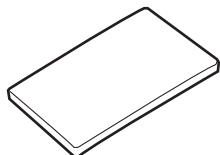

Fuse label  
(LX model only)

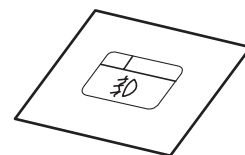

10A Fuse



### TOOL AND SUPPLIES REQUIRED

- Phillips screwdriver
- Stubby #2 Phillips screwdriver
- 10 mm Socket
- Ratchet
- Diagonal cutters
- 10 mm Combination wrench
- Drill
- 3 mm, 6 mm, 7 mm, 10 mm, Drill bit
- Eye protection (face shield, safety goggles, etc.)
- Hacksaw blade
- File
- Masking tape
- Flat-tip screwdriver
- Felt-tip pen
- Pushpin
- Blanket
- Isopropyl alcohol
- Shop towel
- Scissors

### INSTALLATION

**Customer Information:** The information in this installation instruction is intended for use only by skilled technicians who have the proper tools, equipment, and training to correctly and safely add equipment to your vehicle. These procedures should not be attempted by "do-it-yourselfers."

#### NOTE:

- Be careful not to damage the body finish.
  - Take care not to damage the clips and tabs.
1. Make sure you have the anti-theft code for the radio, then write down the radio station presets.
  2. Disconnect the negative cable from the battery.

- Remove the radiator cover (ten clips).

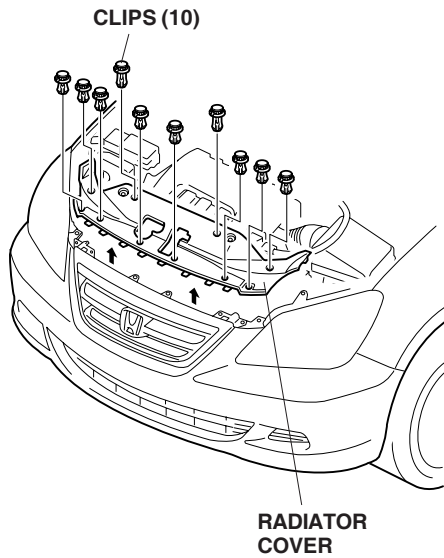

- Remove the front bumper.
  - On each side, pull the inner fender back, and remove the two self-tapping screws.
  - Remove the eight clips.
  - Remove the two bolts, and remove the front bumper.
  - Place the front bumper on a blanket.

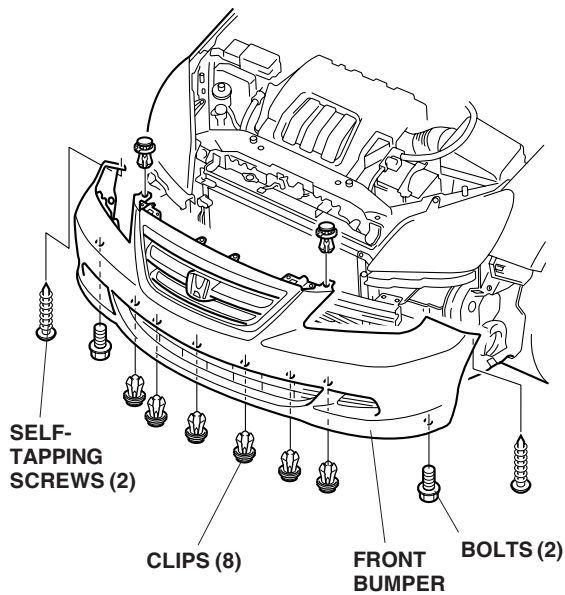

### Cutting the Front Bumper

- To protect the bumper, apply masking tape to the front side of the bumper around the right and left fog light opening.

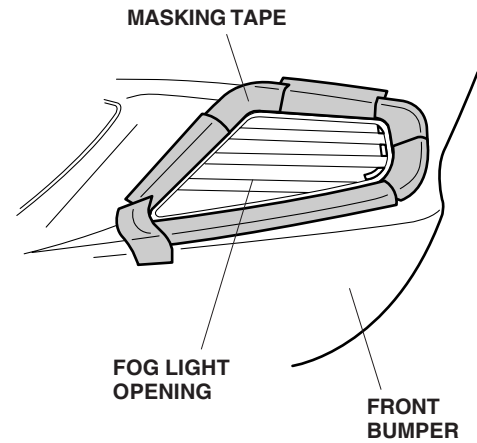

- On the inside of the bumper, align the template with the left fog light mounting position. Using a pushpin mark, the bumper at each of the six locations on the template. Ignore the pre-scribed line.

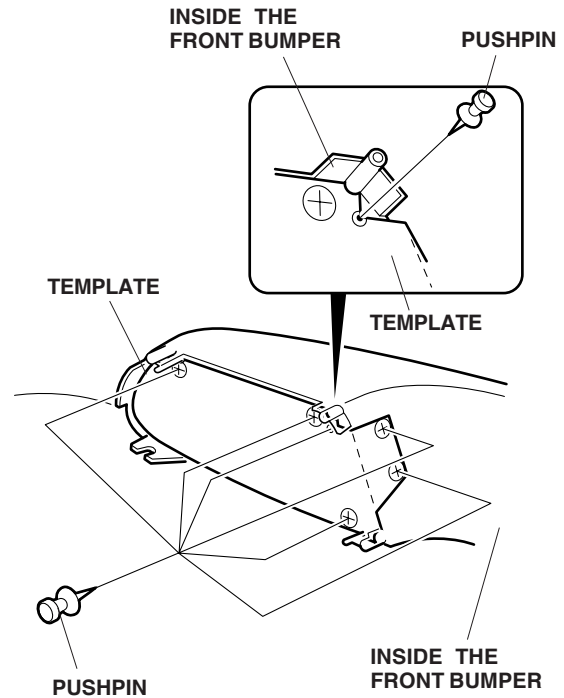

- Using a felt-tip pen, mark the bumper in the area shown.

**NOTE:** If there are pre-scribed lines on the bumper, ignore the pre-scribed lines, and use the template as the guide.

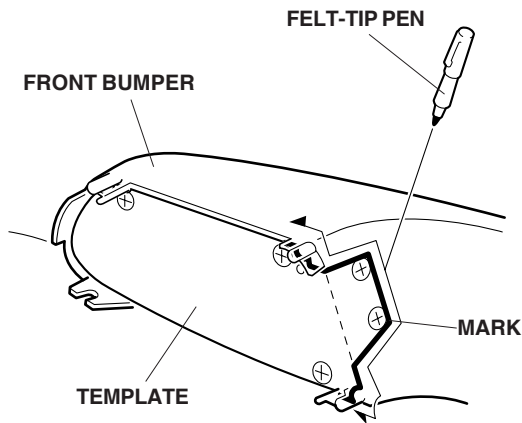

- Turn the template over, and mark the other side of the bumper the same way.
- While wearing eye protection, drill one 7 mm hole and four 10 mm holes at the marked locations. Start with a 3 mm drill bit, and finish with a 7 mm or a 10 mm drill bit.

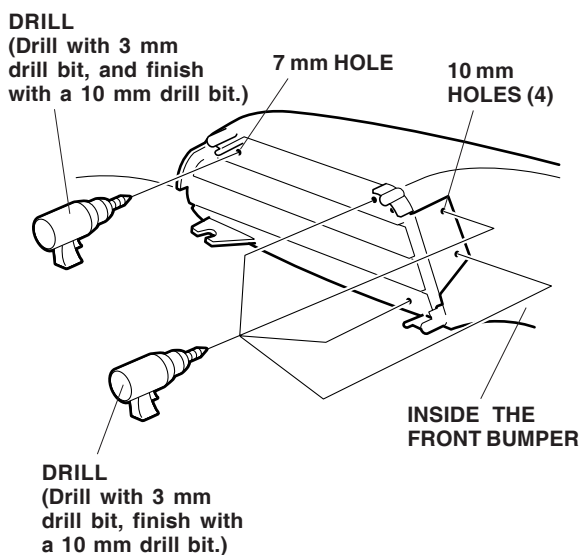

- On the outside of the front bumper, use a hacksaw blade to cut the bumper at the fog light opening along the three sides.

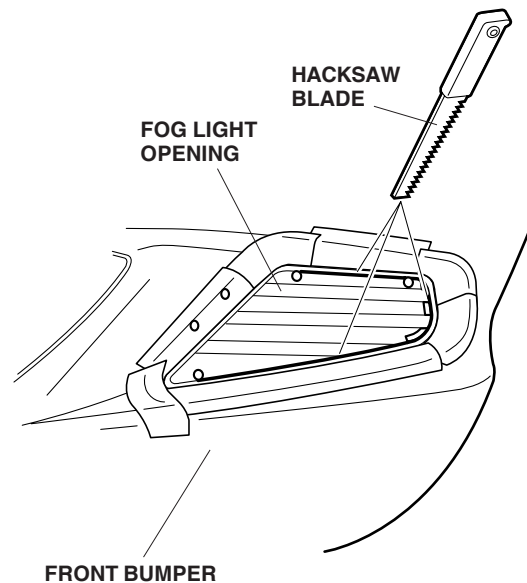

- On the inside of the front bumper, cut out the fog light opening from the front bumper using a hacksaw blade. Remove any burrs, and remove masking tape.

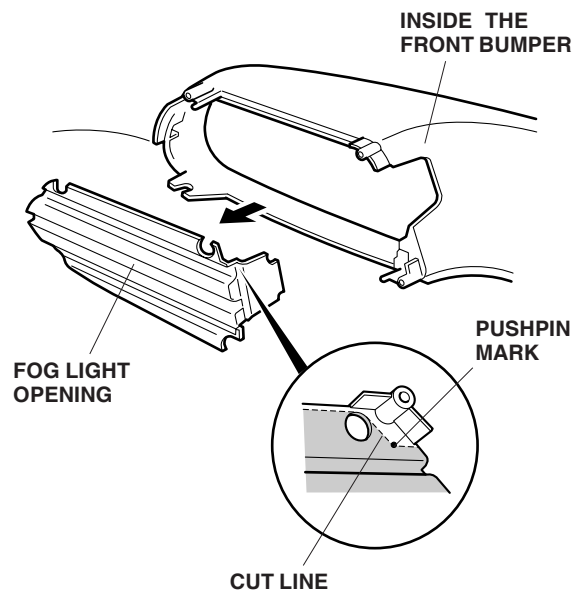

## Installation the Fog Light

12. Install the left bracket to the front bumper using three self-tapping screws.

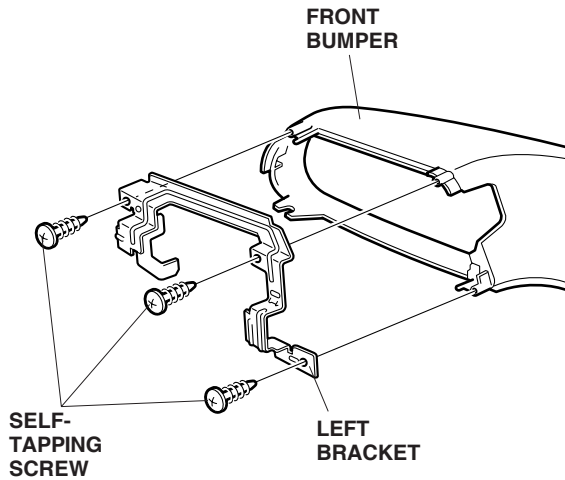

13. Insert the fog light through the opening in the front bumper and into the bracket.
14. Install the fog light to the bracket using one 5 x 16 mm washer bolt.

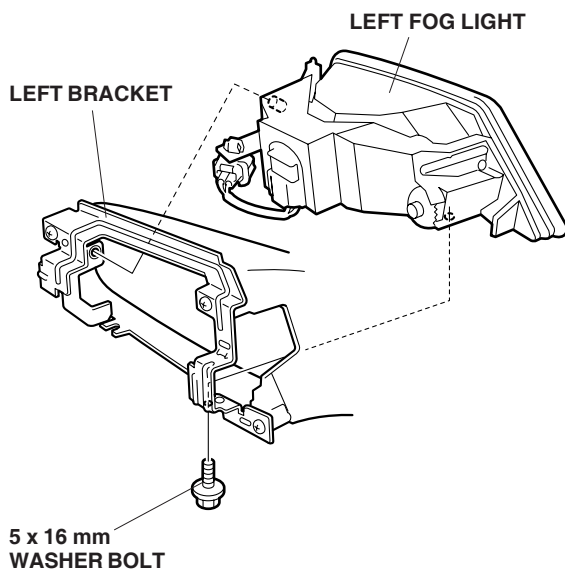

15. Repeat steps 9 through 14 to cut the bumper, and install the right fog light.

## Routing the Fog Light Harness

16. Open the hood. Remove the FI-ECU cover (two clips).

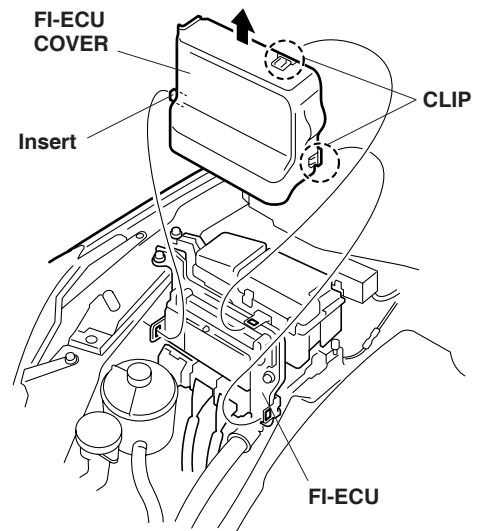

17. Remove the two under-hood fuse relay box bolts, and slide the relay box to the side.

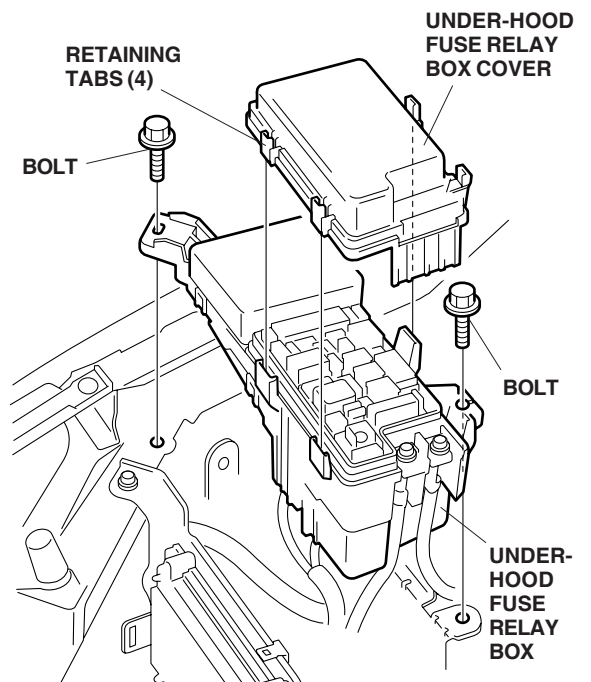

18. Remove the under-hood fuse relay box cover (four retaining tabs).

19. Lower the under-hood fuse relay box lower cover from the under-hood fuse relay box (six retaining tabs).

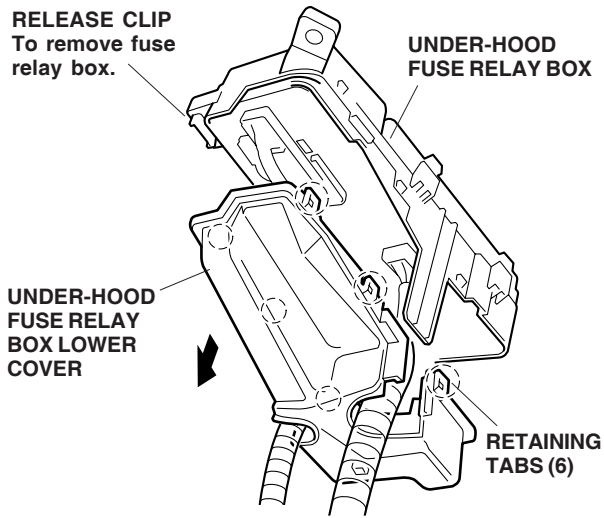

*If the vehicle you are working on is an LX model, go to step 28; otherwise, continue with step 20.*

20. Near the under-hood fuse relay box locate the subfuse box. Remove the subfuse box cover (two tabs).

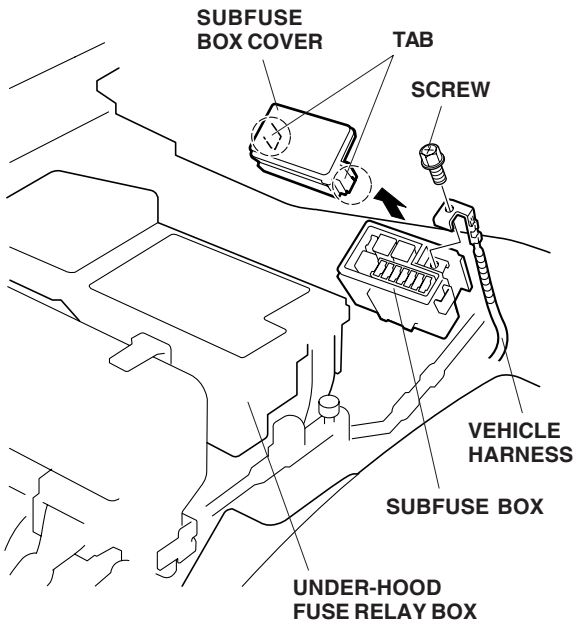

21. Remove the screw, and disconnect the vehicle harness.

22. Remove the subfuse box from the vehicle bracket.

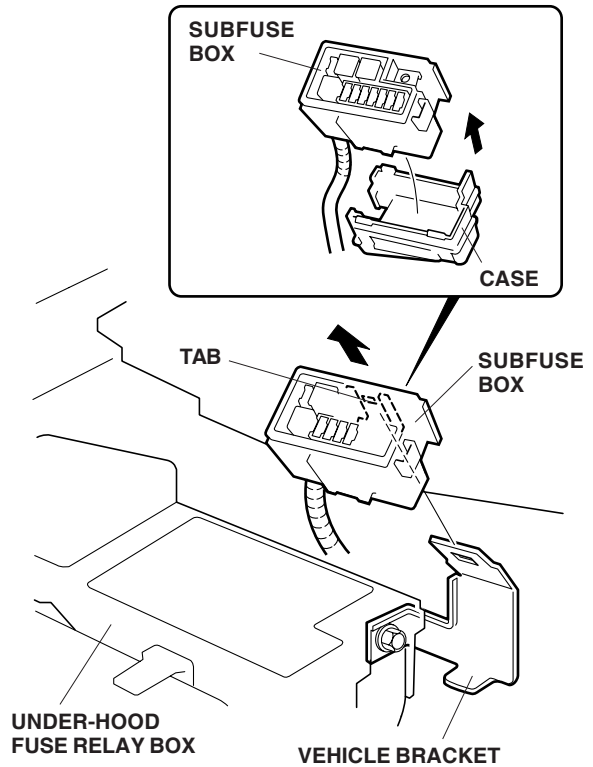

23. Remove the subfuse use box from the case (one tab).

24. Get the long subharness. Plug the 1-pin terminal from the long subharness into the rear of the subfuse box at the location shown.

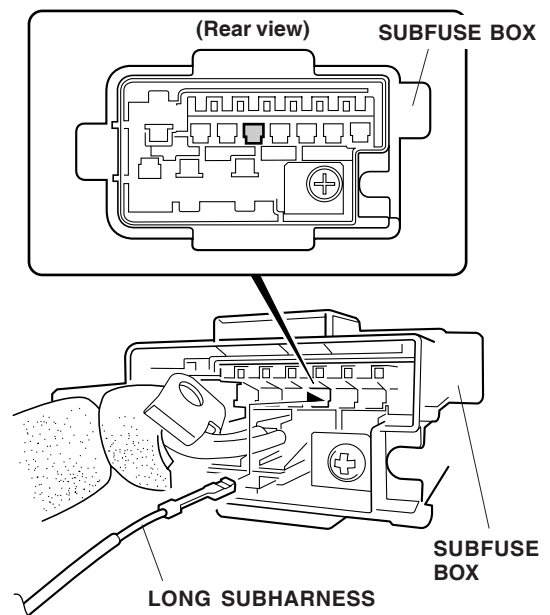

- Secure the long subharness to the subfuse box harness with one small wire tie.

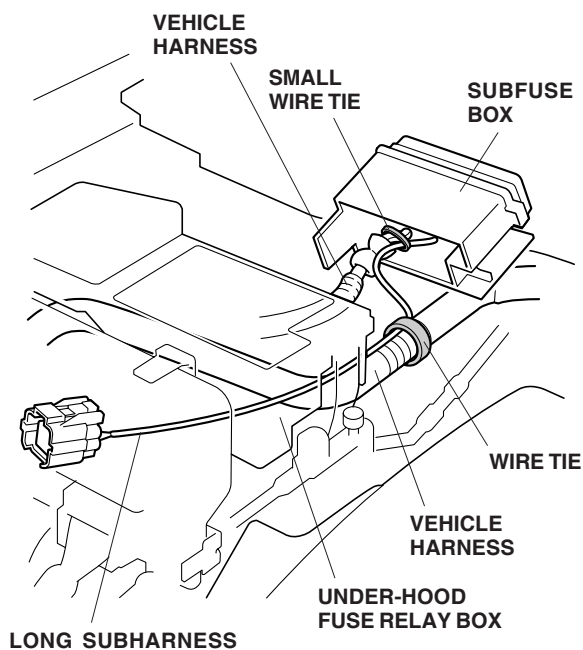

- Secure the long subharness to the vehicle harness with one wire tie.
- Reinstall the subfuse box.

***If the vehicle you are working on is an EX or Touring model, go to step 31; otherwise, continue with step 28.***

- Disconnect the vehicle 20-pin connector from the bottom of the under-hood fuse relay box.

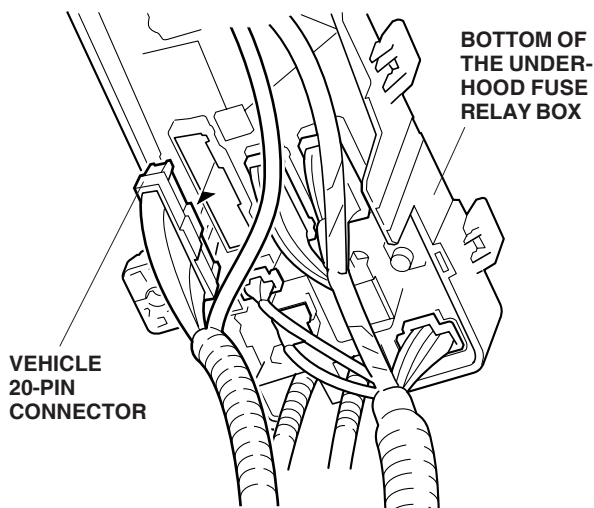

- Get the short subharness, plug the 1-pin terminal from the short subharness into the back of the vehicle 20-pin connector.

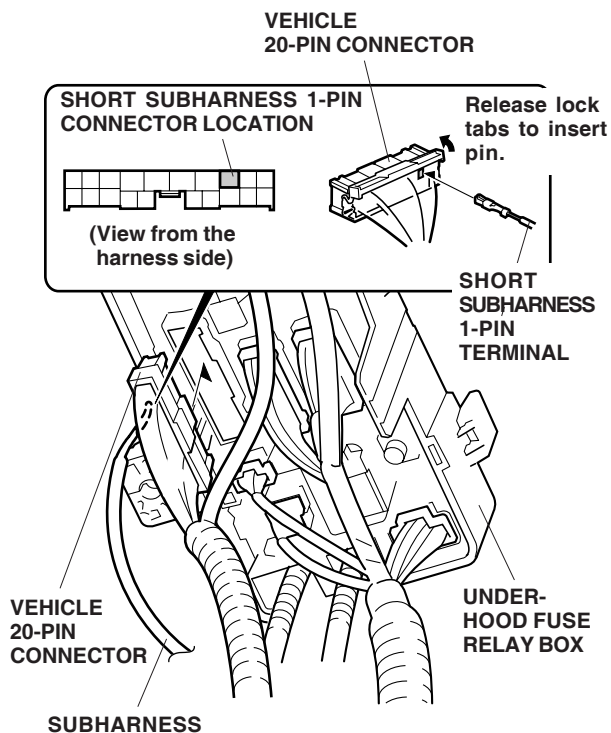

- Reconnect the vehicle 20-pin connector into the under-hood fuse relay box.
- Disconnect the vehicle 18-pin connector from the back of the under-hood fuse relay box.

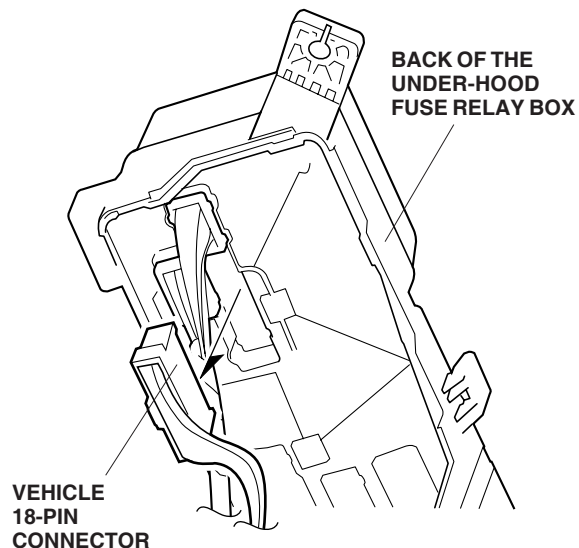

32. Get the fog light harness. Plug the 1-pin white/green and the 1-pin red/green terminals into the back of the 18-pin connector in the locations shown.

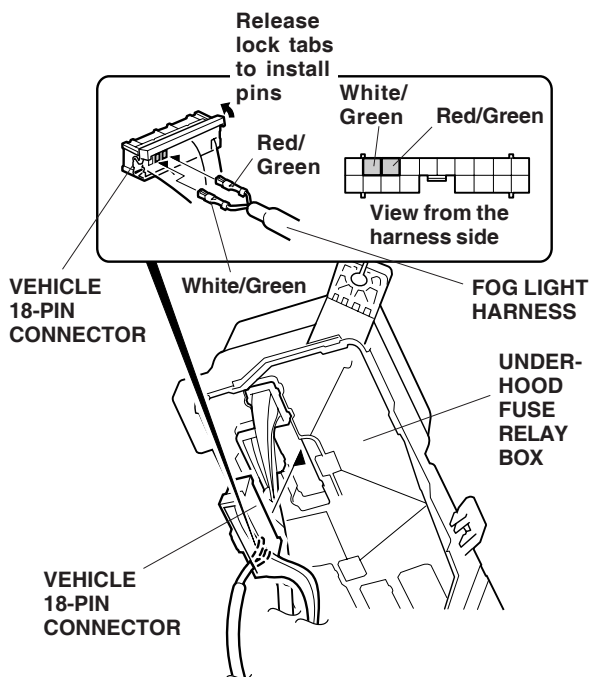

33. Reconnect the vehicle 18-pin connector into the under-hood fuse relay box.
34. Plug the connector from the long/short sub harness into the fog light harness connector. Secure the fog light harness and the sub harness to the vehicle harness with one small wire tie, and trim wire tie.

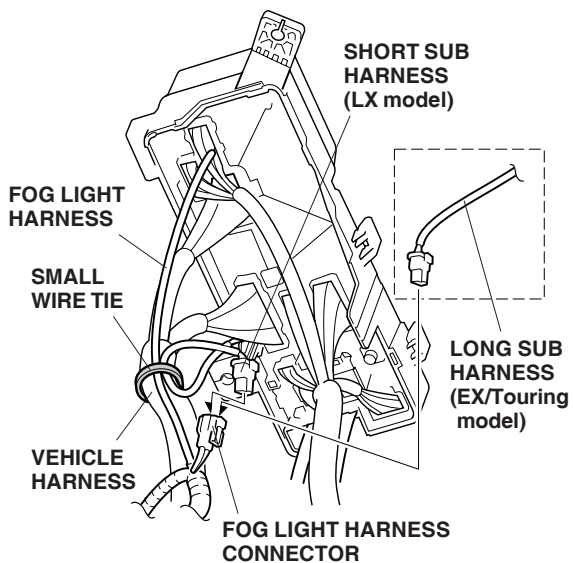

35. Reinstall the under-hood fuse relay box lower cover in the original position.

36. Below the under-hood fuse relay box, secure the fog light harness connector to the vehicle harness using the wire tie with holder, and trim the wire tie.

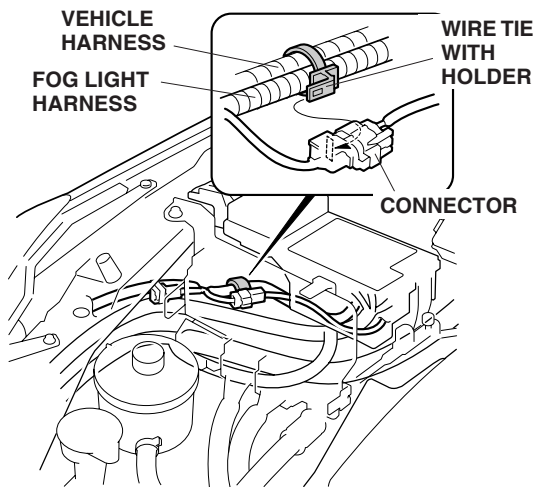

37. Using the isopropyl alcohol, thoroughly clean the areas where the cushion tape will attach. Using scissors, cut one a cushion tape in half, and attach one half to the FI-ECU in the area shown.
38. Locate the vehicle 2-pin connector blue taped to the vehicle harness, and remove the blue tape to free the connector. Plug the fog light harness 2-pin connector into the vehicle harness 2-pin connector.

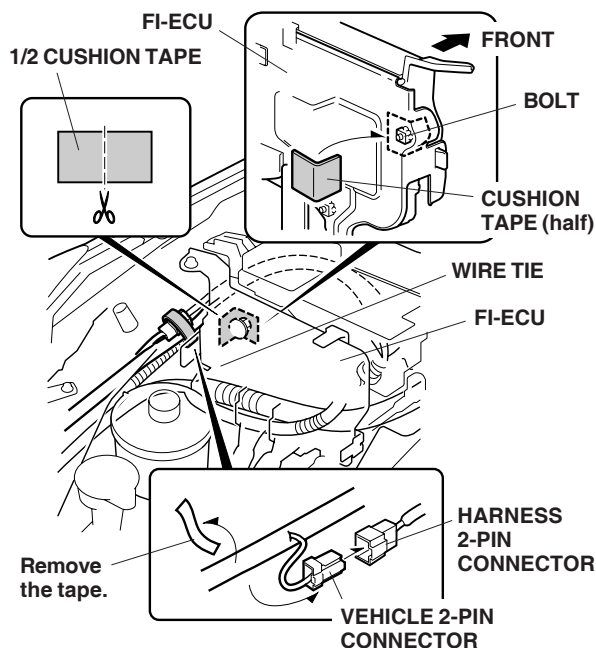

39. Secure the fog light harness connector to the vehicle harness using one wire tie.



40. Route the fog light harness forward along the vehicle harness, and loosely secure it to the vehicle harness with two wire ties.

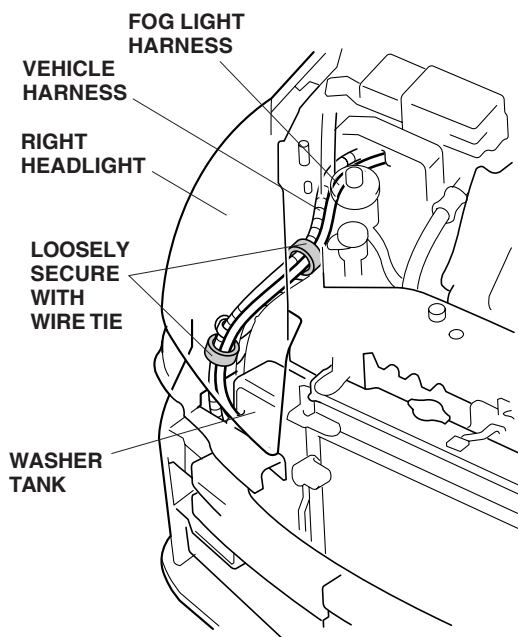

41. Route the right fog light harness 2-pin connector along the vehicle harness and into the bumper area.

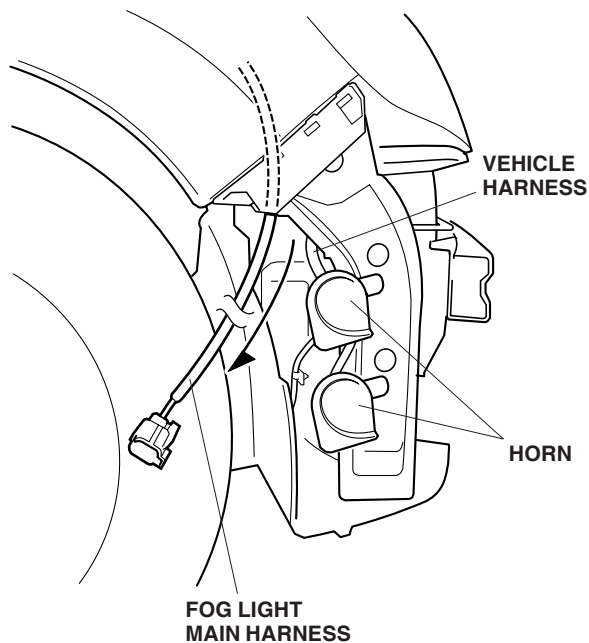

42. Attach the two wire tie with clips from the fog light harness into the holes in the vehicle body.

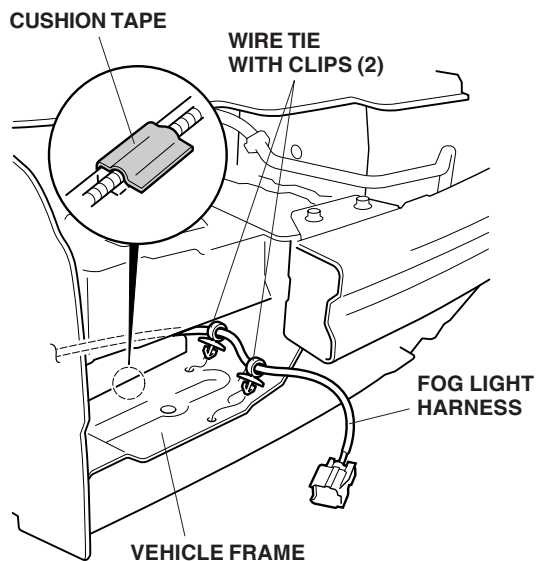

43. Using the isopropyl alcohol, thoroughly clean the areas where the cushion tape will attach. Secure the fog light harness to the vehicle's frame with the cushion tape.
44. Adjust the fog light harness until the green tape on the fog light harness is close to the wire tie with clip from the vehicle harness. Secure the fog light harness to the vehicle harness with two wire ties.

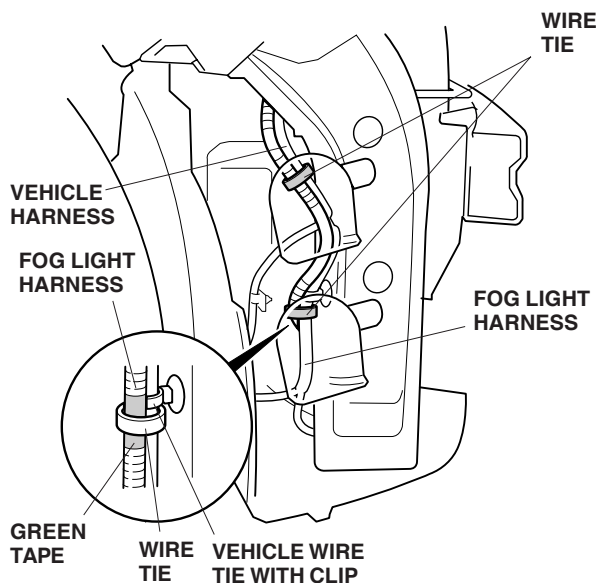

45. Tighten the two wire ties from step 40.

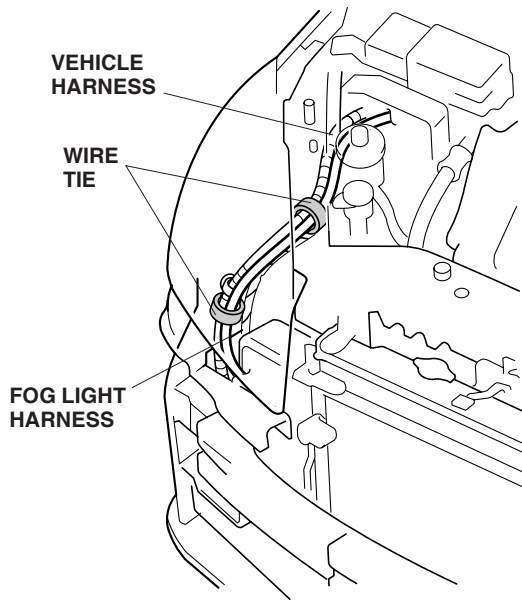

46. Reinstall the under-hood fuse relay box.

47. Remove the power steering reservoir from the vehicle bracket.

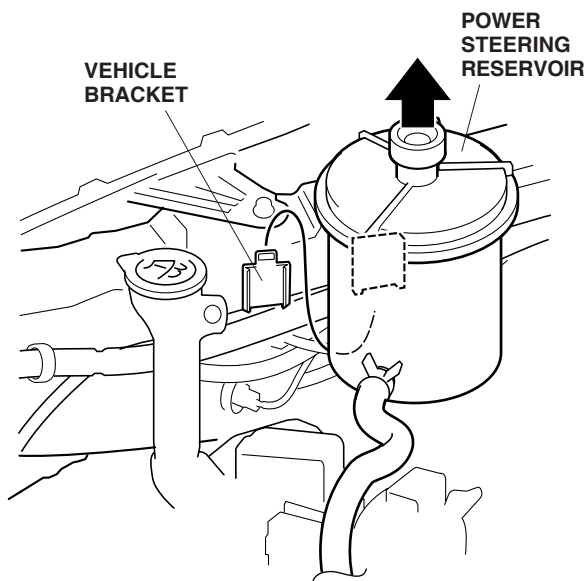

48. Route the fog light harness along the vehicle harness. Attach the fog light harness to the vehicle harness with two wire ties.

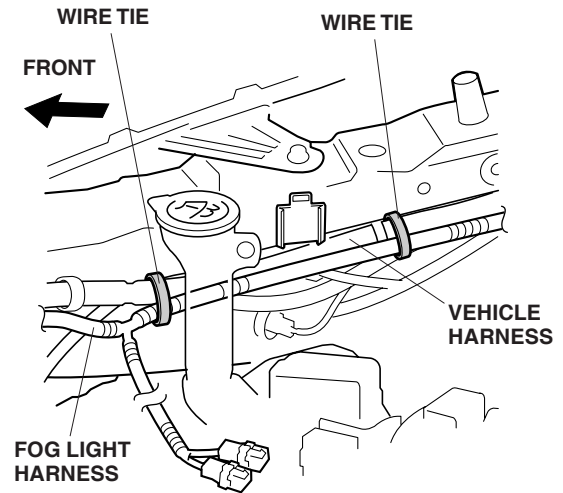

49. Route the fog light harness along the vehicle harness of the bulkhead, and loosely attach the fog light harness to the vehicle harness with four wire ties.

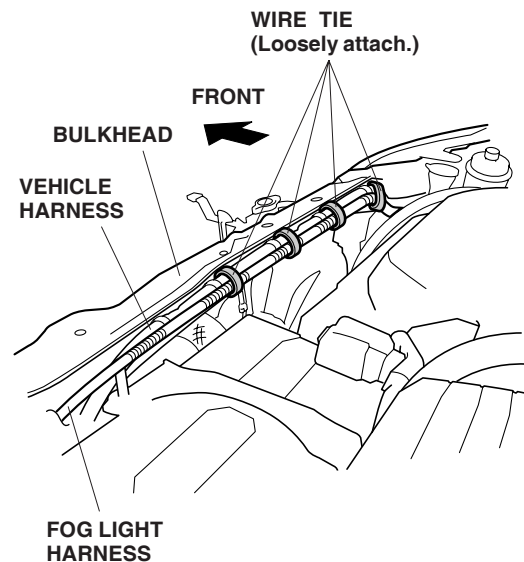

50. Route the fog light harness behind the battery, and loosely secure it to the vehicle harness with three additional wire ties.

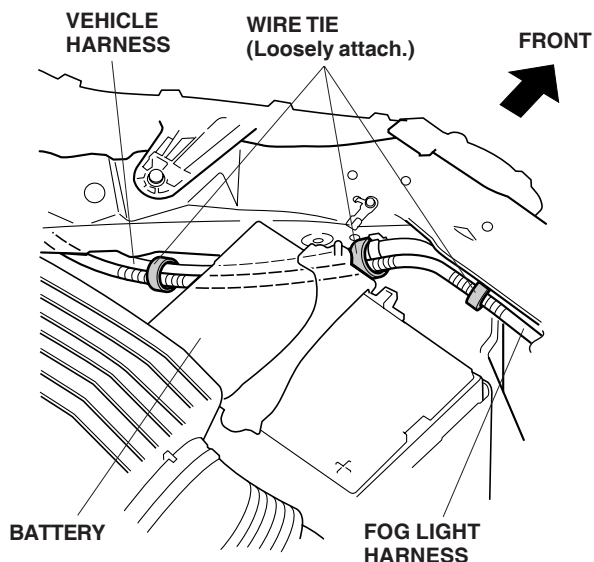

51. Locate the wire tie with clip near the end of the fog light harness. Wrap a cushion around the fog light harness at the measurement shown.

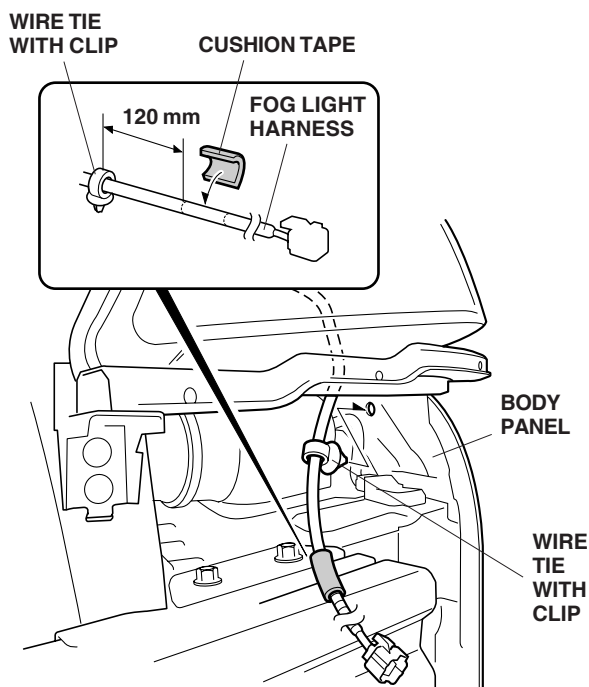

52. Attach the wire tie with clip from the fog light harness into the hole in the body panel.

53. Route the fog light harness as shown.

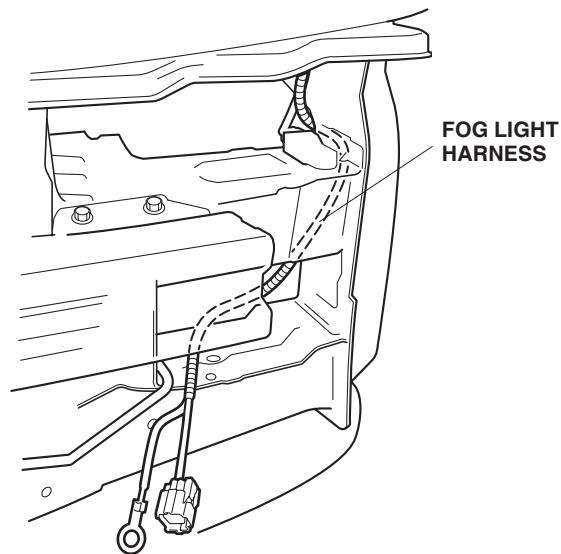

54. **EX model with AUTO air:** Secure the fog light harness to the sensor harness using three wire ties.

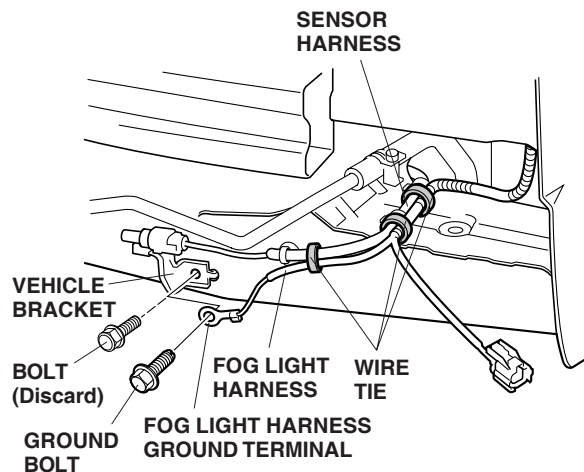

55. **EX model with AUTO air:** Remove the bolt from the vehicle bracket. Secure the ground terminal from the fog light harness to the vehicle bracket using the ground bolt supplied.

56. **LX Model:** Route the fog light harness as shown and secure it with three wire ties with clip to the vehicle frame.

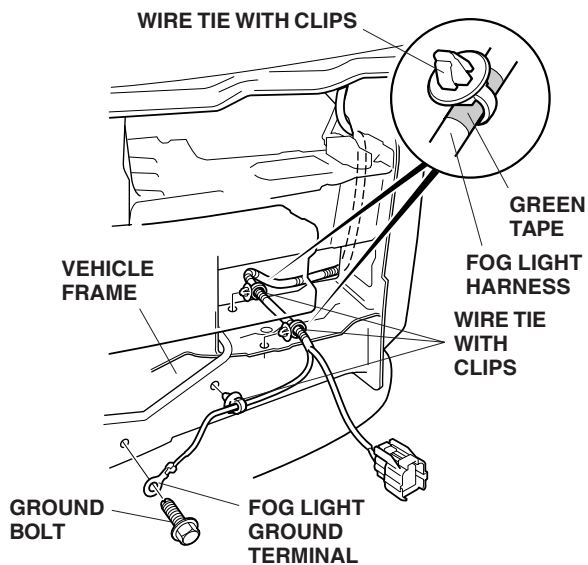

57. **LX Model:** Use the ground bolt and tighten the ground terminal of the fog light harness to the vehicle frame.
58. Using the isopropyl alcohol, thoroughly clean the areas where the cushion tapes will attach. Secure the fog light harness to the vehicle frame with one cushion tape.

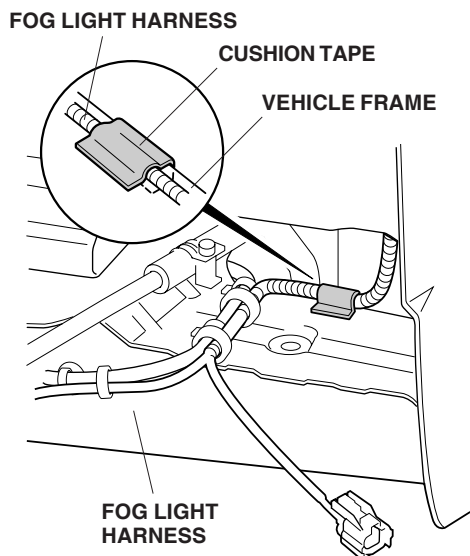

59. Loosely tighten the seven wire ties to the vehicle harness.

60. Get the relay bracket and the two relays. Attach the relays to the relay bracket using two 6 x 16 mm bolts for each relay.

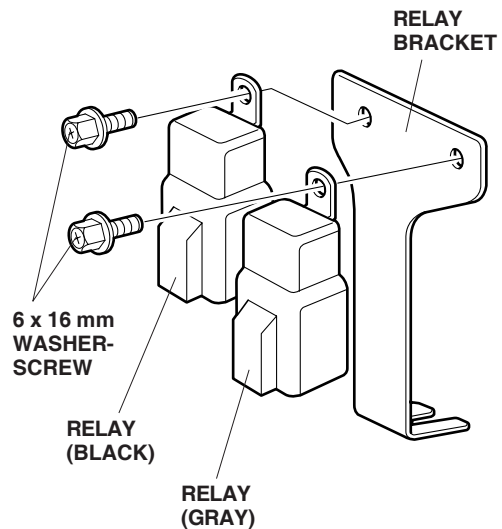

61. Plug the blue fog light harness 4-pin connector in to the gray relay. Plug the brown fog light harness 4-pin connector into the black relay.

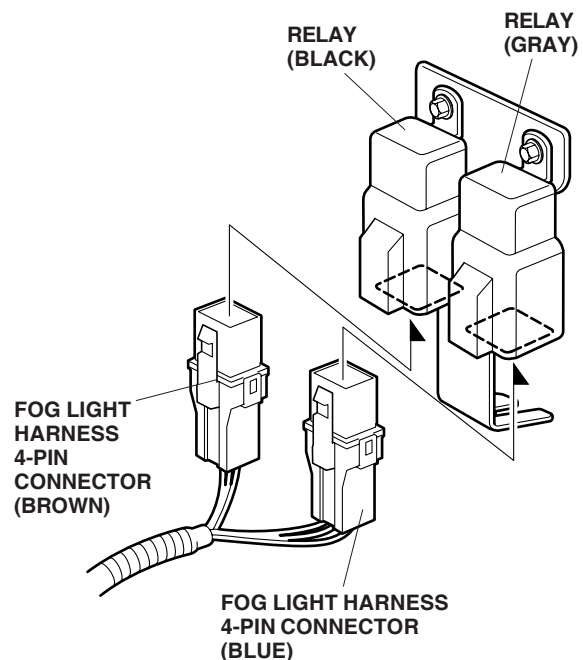

62. Loosen the bolt that secures the existing relay box, and slide the tab from the fog light relay bracket under the bolt. Re-tighten the relay bracket bolt.

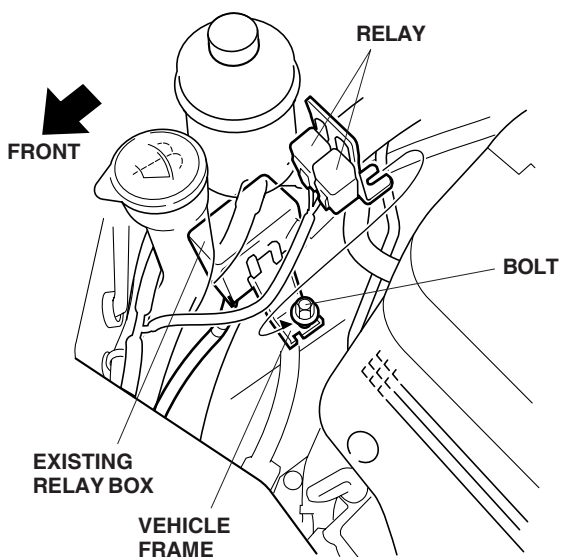

63. Secure the fog light harness from the relay box to the vehicle harness with three wire ties.

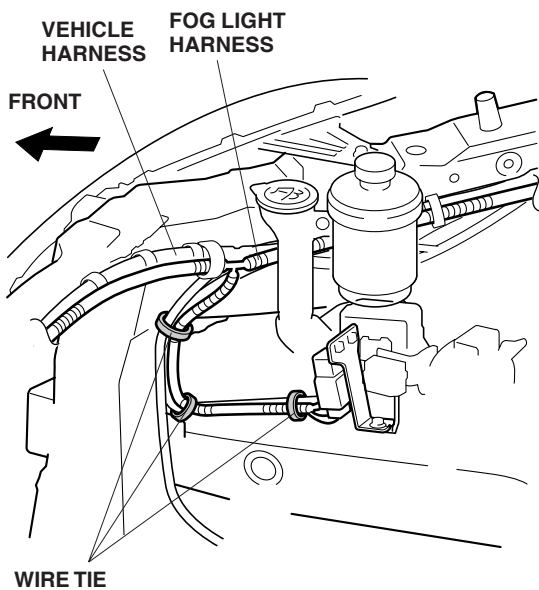

64. With the help from an assistant, plug the fog light harness 2-pin connectors into the fog light connectors, and reinstall the front bumper in its original position. Be careful that the fog light harness does not get caught between the bumper and the splash shield.

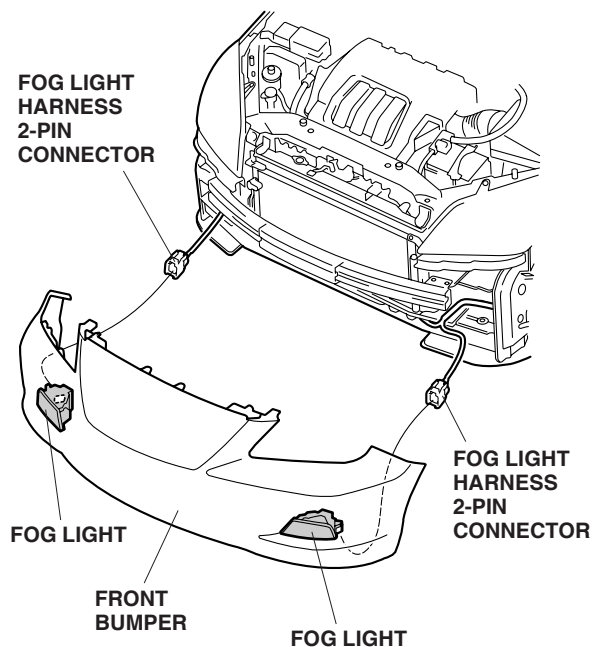

### Installing the Fog Light Switch

65. Remove the instrument side panel cover (six clips, three retaining tabs).

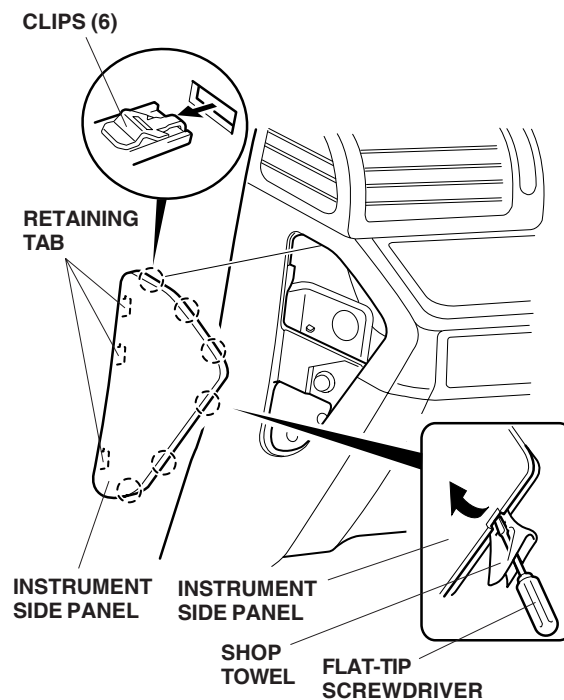

66. Reaching through the opening in the dashboard, release the four clips. Pull out on the switch panel. If equipped, disconnect the vehicle connectors from the switch panel, and remove the switch panel.

*EX Model Shown*

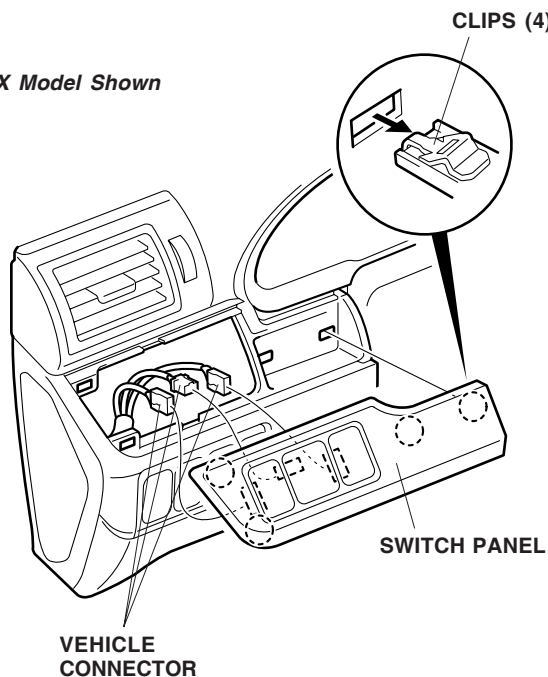

67. Remove the switch lid (two retaining tabs).

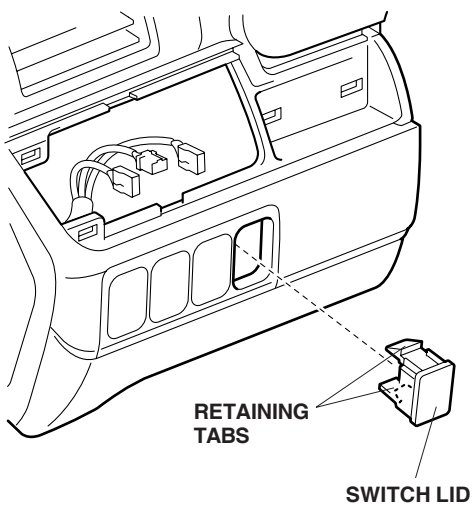

68. Remove the VSA switch. (two retaining tabs).

*EX Model Shown*

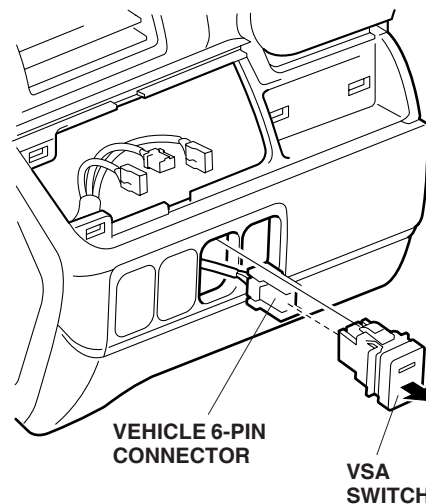

69. Unplug the vehicle 6-pin connector from the VSA switch.
70. Plug the switch harness 5-pin connector into the fog light switch.
71. Install the fog light switch into the hole where you removed the switch lid.

*EX Model Shown*

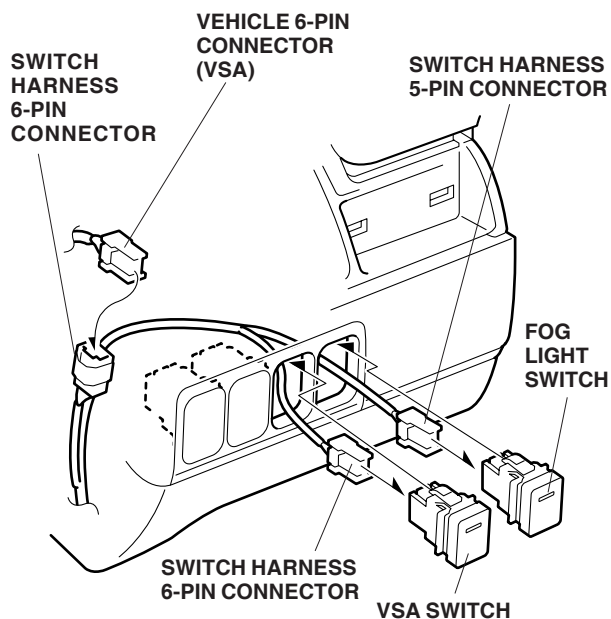

72. Plug the 6-pin switch harness connector into the VSA switch, and plug the vehicle 6-pin VSA connector into the switch harness.

73. Route and fold the switch harness back along the vehicle harness, and secure the switch harness to the vehicle harness with two wire ties to the vehicle harness.

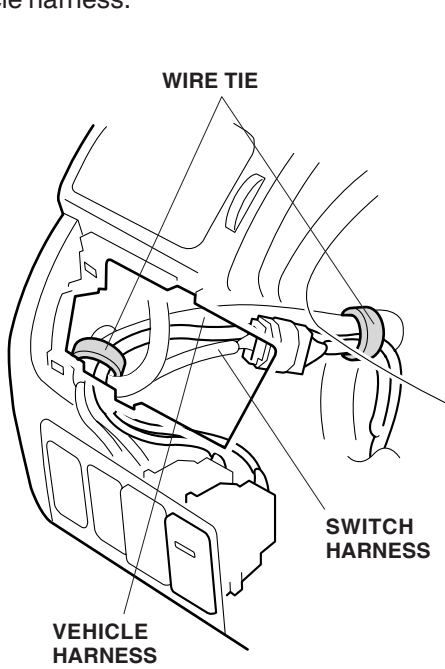

74. Locate the 2-pin connector forward of the fuse box black-taped to vehicle harness near the front bulkhead. Remove the black-tape to free the connector. Plug the 2-pin connector from the switch harness into the vehicle harness 2-pin connector you just freed.

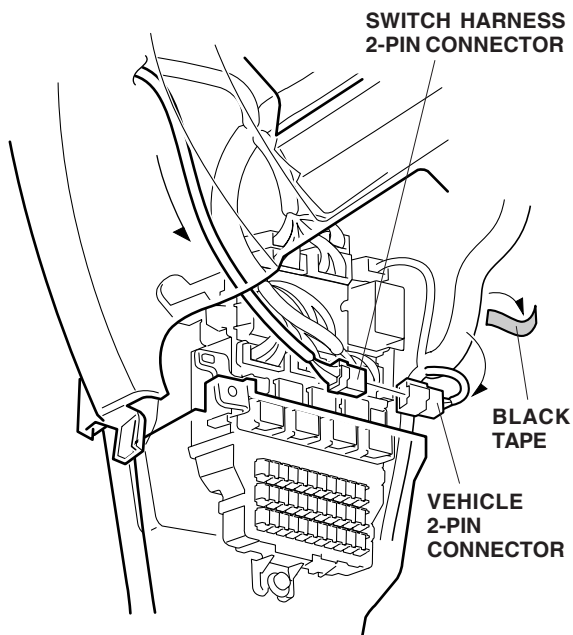

75. At the fuse box, secure the switch harness to the vehicle harness with three wire ties.

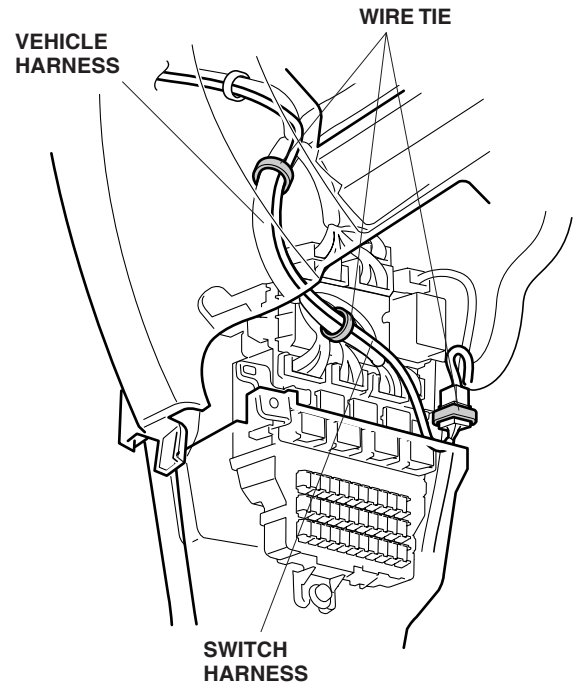

76. Install the 10A fog light fuse.

**EX/Touring Model:** Install the 10A fuse into the sub fuse box in the location shown.

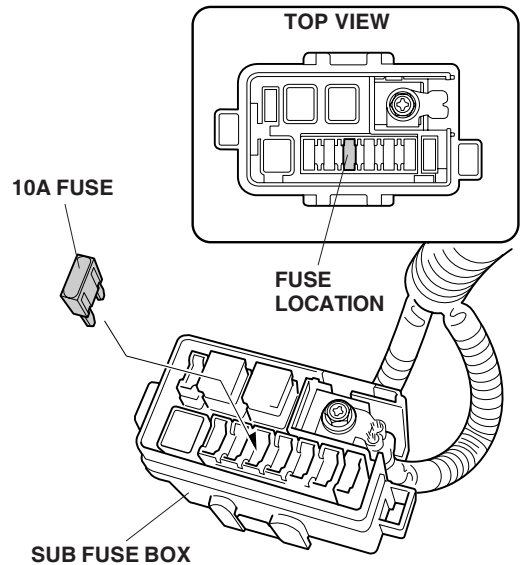

**LX Model:** Install the 10A fuse into the under-hood fuse relay box in the location shown.

**FUSE LOCATION**

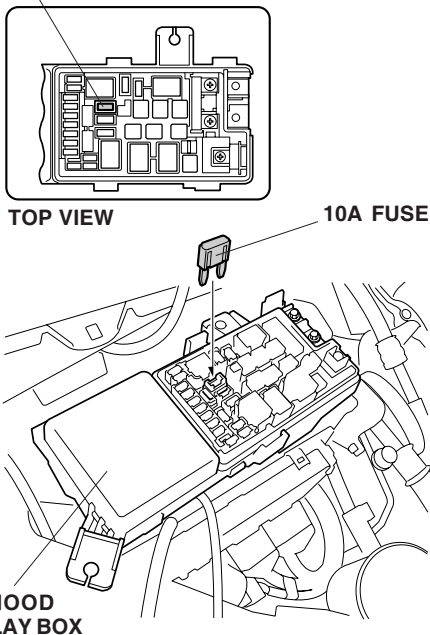

77. **LX Model Only:** Attach the 10A fuse label to the inside of the under-hood fuse relay box.

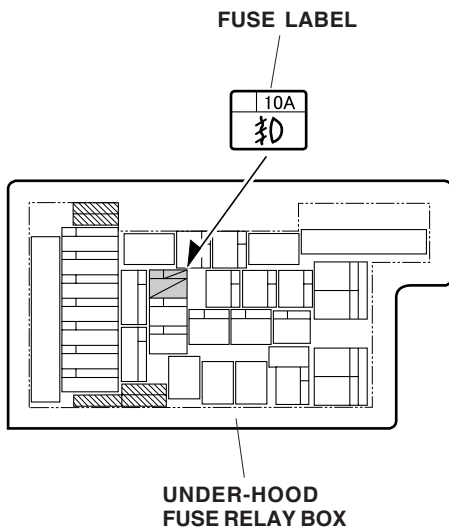

78. Check that all wire harnesses are routed properly, and all connectors are plugged in.
79. Reinstall all removed parts.
80. Reconnect the negative cable to the battery.
81. Enter customer's radio anti-theft code, and reset the station presets.
82. Reset the clock.  
  
**NOTE:** Whenever the battery is disconnected, the driver's AUTO window function is disabled.
83. Start the engine. Push down on the driver's window switch until the window is fully open, then hold switch for 2 seconds or more.
84. Pull up on the driver's window switch to close the window completely, then hold the switch for 2 seconds or more.
85. Test the AUTO window function.



## Fog Light Aiming Adjustment

86. Remove the bolt and clip, and pull down the inner fender.

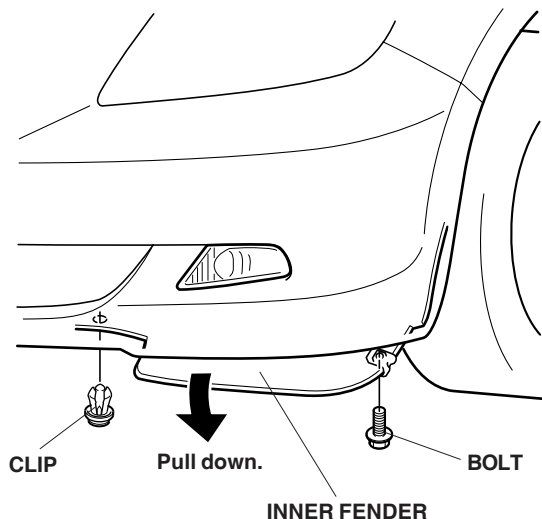

87. Adjust the fog lights.

- Adjust the aiming according to local laws and regulations.
- To adjust, turn the adjustment screw in or out until the correct aiming is obtained.

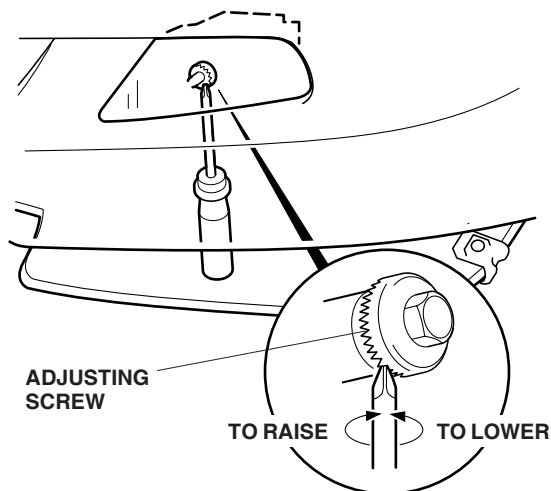

## USE AND CARE

### How to Operate Fog Lights

- Turn the light switch to the "on" position (headlights on low beam ).
- Press the fog light switch (indicator is on).
- If the fog lights don't come on, check the fuse and all the connectors, including the ground cable and the fusible link.

NOTE: The fog light lenses can cloud when the outside temperature is cold; this is normal and should go away in warm weather.

### Replacing the Bulb

NOTE:

- Use only a Honda Genuine Halogen Light Bulb of specified wattage.  
BULB, FOG LIGHT (H8)  
P/N 33165-S5A-J010-M1
- Do not touch the bulb. Oily or greasy substances on the bulb can shorten its service life due to the heat produced when the bulb is turned on. If the bulb is accidentally touched, wipe it clean with a clean, soft cloth that has been dampened with denatured alcohol or a mild detergent solution.
- Align the tab on the fog light with the cutout in the bulb socket when installing the new bulb. If not aligned, there is possibility that the fog light may annoy oncoming drivers.

1. Remove the bolt and clip, and pull down the inner fender.

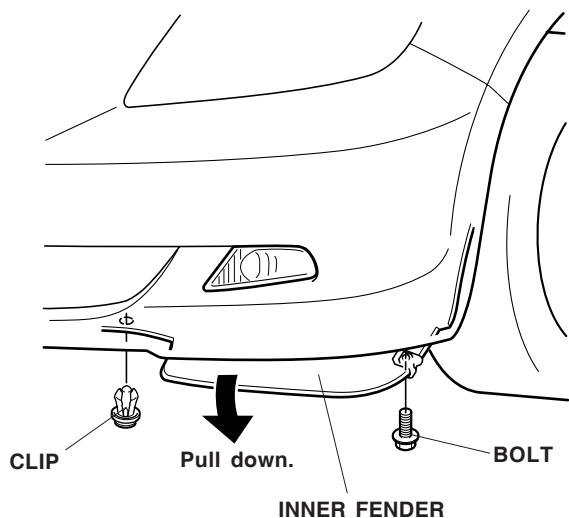

2. Unplug the connector from the fog light.

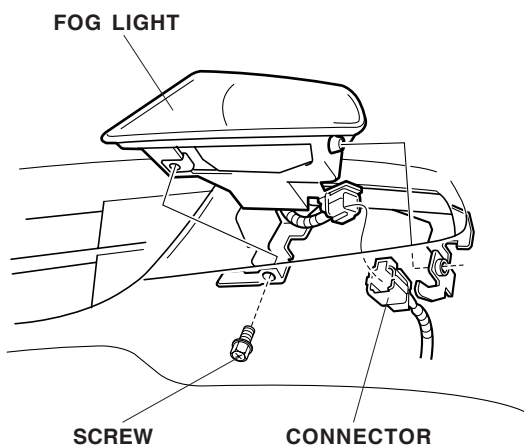

3. Remove the screw that fastens the fog light, and pull the light out toward you.

4. Unplug the connector from the bulb, and remove the bulb from the fog light.

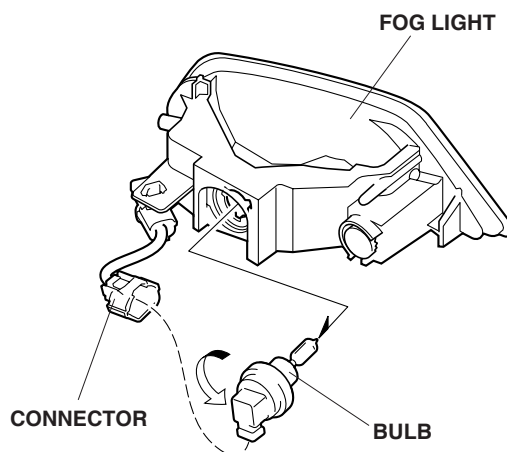

5. Install the new bulb into the fog light.

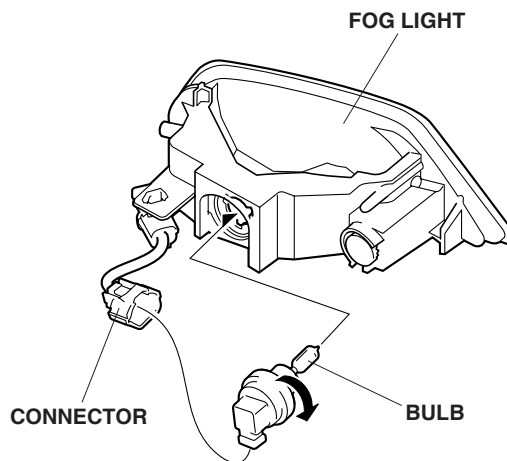

6. Reinstall the removed parts in the reverse order of removal:
  - Check that the wire harnesses are not pinched.
  - Be sure to tighten the self-tapping screw and bolts securely.
7. Check the operation of the fog light; adjust the aiming if necessary.

# CIRCUIT DIAGRAM

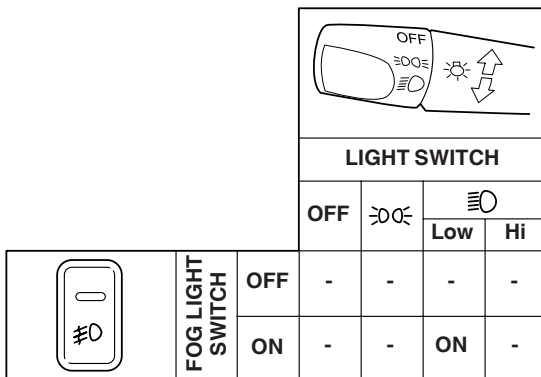
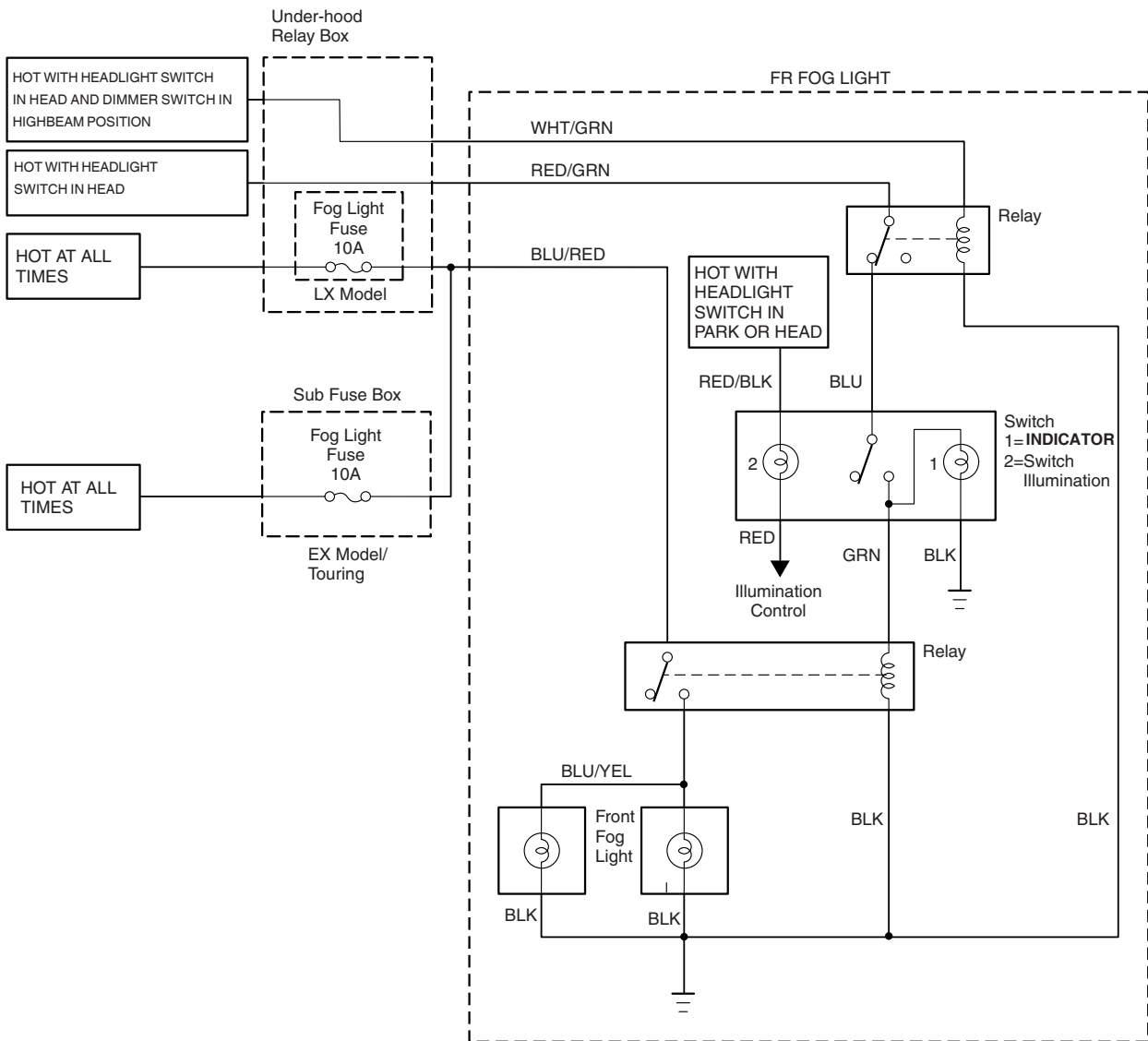

BLK	BLACK	BRN	BROWN
YEL	YELLOW	ORN	ORANGE
BLU	BLUE	PUR	PURPLE
GRN	GREEN	NAT	NATURAL
RED	RED	PNK	PINK
WHT	WHITE	GRY	GRAY
LT BLU	LIGHT BLUE	LT GRN	LIGHT GREEN