



INSTALLATION INSTRUCTIONS

Accessory

BACKUP SENSOR

Application

2005 ODYSSEY

Publications No.

All 27336

Issue Date

SEP 2004

PARTS LIST

Backup Sensor Attachment Kit P/N 08V67-SHJ-100A

Backup sensor control unit

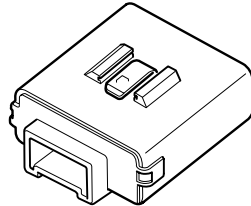

Buzzer

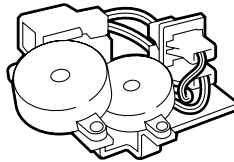

Switch

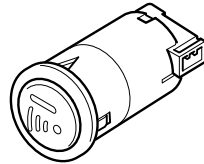

Backup sensor harness

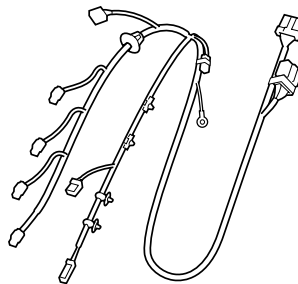

Buzzer bracket

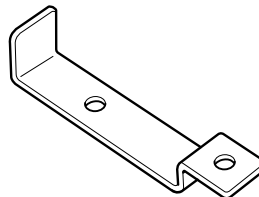

Control unit bracket

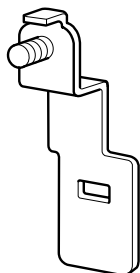

15 Black wire ties

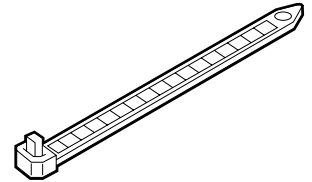

2 Small wire ties

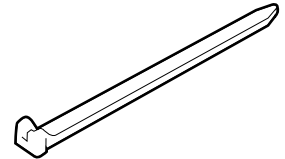

3 Long wire ties

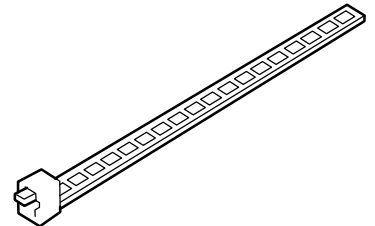

2 Cable clips

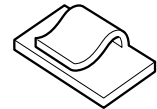

Blind nut



Washer-screw, 4 x 14 mm



Flange bolt, 6 x 12 mm



2 Flange nuts 6 mm



Fuse label

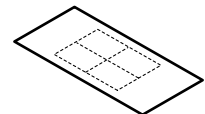

Cushion

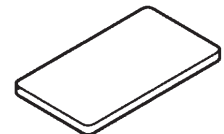

2 EPT seals

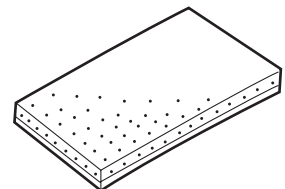

Backup Sensor Kit

2 Corner sensors

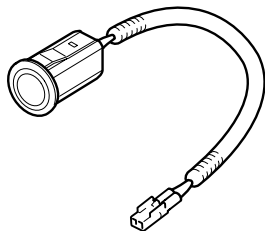

2 Center sensors

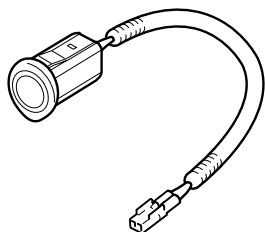

2 Spacers

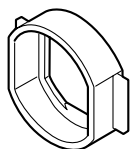

TOOLS AND SUPPLIES REQUIRED

#2 Phillips screwdriver
Small flat-tip screwdriver
Felt-tip pen
10 mm Combination wrench
10 mm and 14 mm Socket
Pushpin
Ratchet
3 mm, 8 mm, Drill bit
Eye protection (face shield, safety goggles, etc.)
File
Diagonal cutters
Scissors
Masking tape
Tape measure
Cardboard
Isopropyl alcohol
Shop towel
22 mm and 26 mm Holesaws
Drill
Utility knife

Illustration of the Backup Sensor Installed on the Vehicle

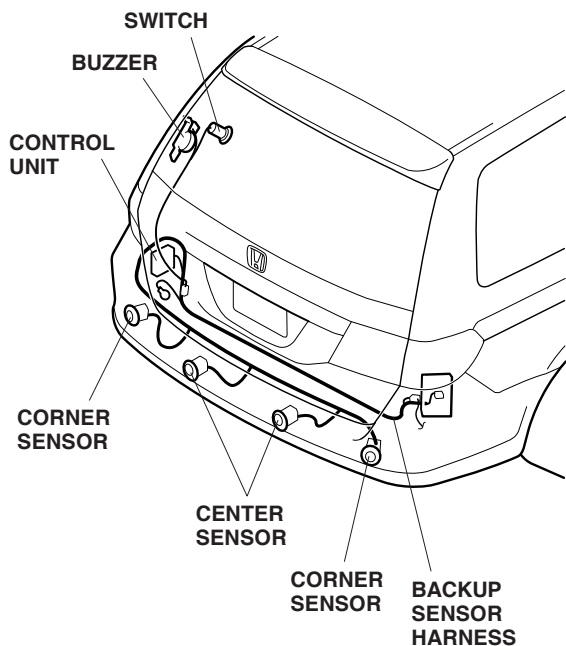

INSTALLATION

Customer Information: The information in this installation instruction is intended for use only by skilled technicians who have the proper tools, equipment, and training to correctly and safely add equipment to your vehicle. These procedures should not be attempted by “do-it-yourselfers.”

1. Make sure you have the anti-theft code for the radio, then write down the radio station presets.
2. Disconnect the negative cable from the battery.

3. Remove the rear bumper:

- Remove the three clips along the bottom of the bumper.
- Remove the six screws (three on each side) from the fenderwell area.
- Using a flat-tip screwdriver, pry out and remove the bumper bolt covers, then remove the four bumper bolts.
- With the help of an assistant, release the bumper from the fenderwell, and slide the bumper away from the vehicle.
- Set the bumper on a blanket.

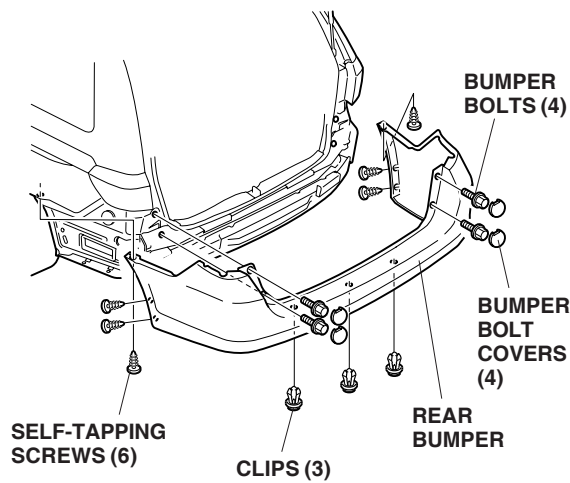

4. Remove the driver's sliding door sill trim (five clips).

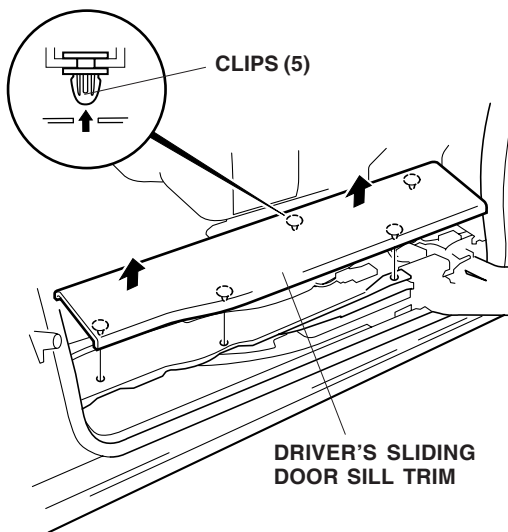

5. Pull away the weatherstrip from the rear trim panel. Remove the rear trim panel (ten clips, and two screws).

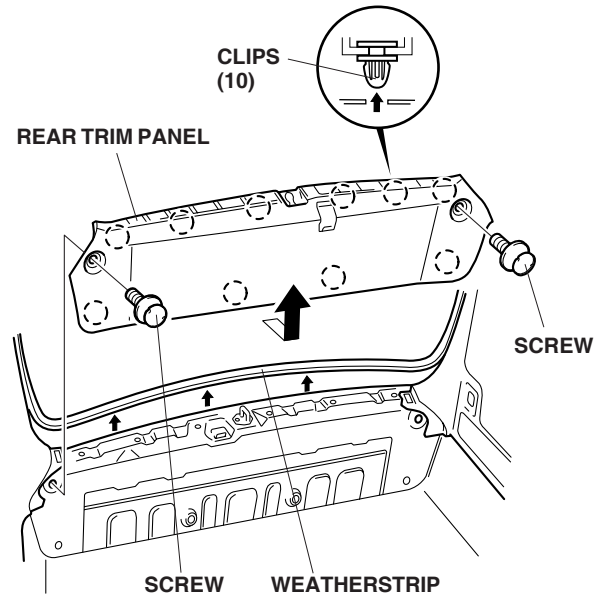

6. Remove the spare tire cover (17 tabs).

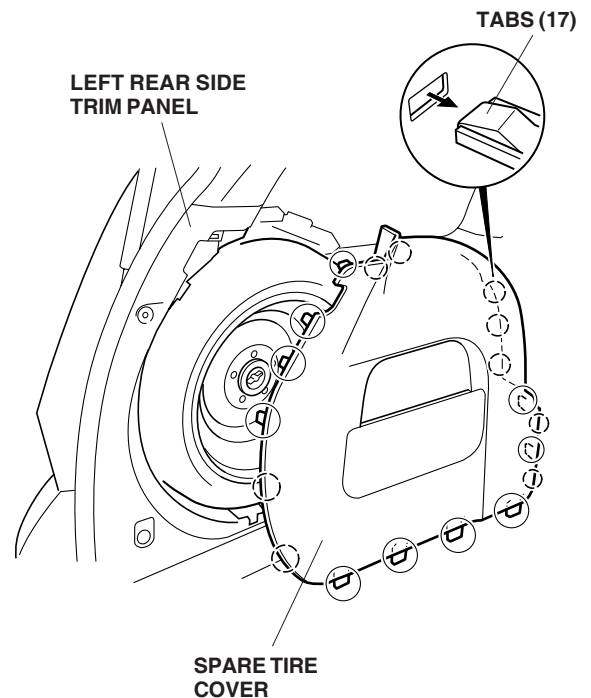

- Remove the anchor bolt and the anchor bolt cover, and take out the spare tire.

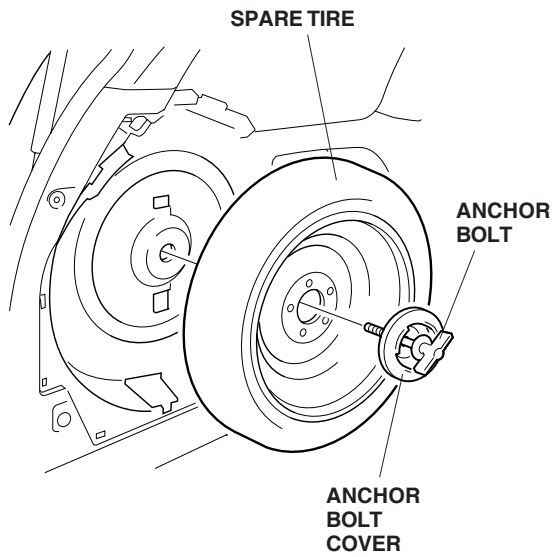

- Remove the jack cover (2 tabs).

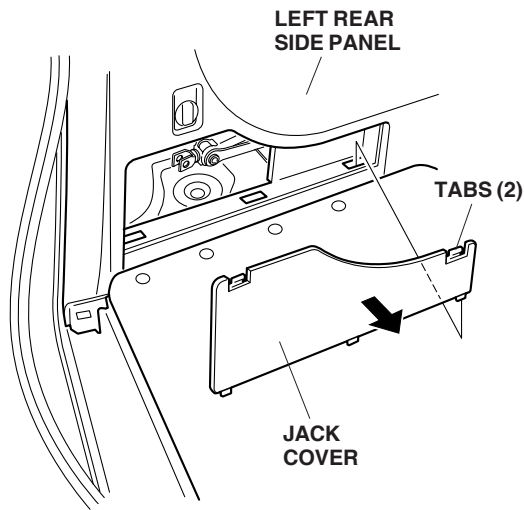

- Remove the left second row seat belt upper anchor cover (two tabs). Remove the left second row seat belt upper anchor bolt.

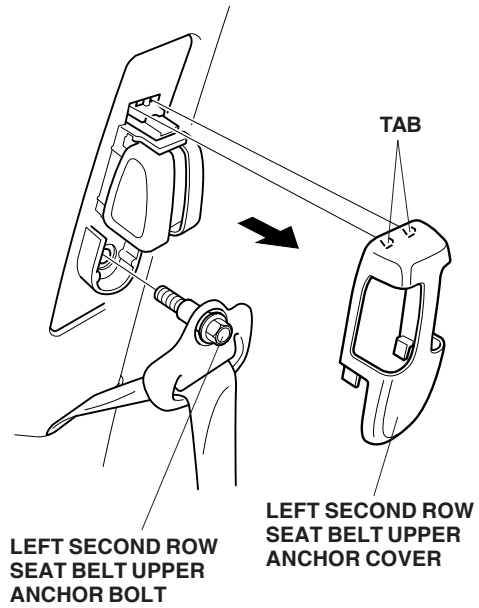

- Pull away the weatherstrip from the left quarter pillar trim. Remove the left quarter pillar trim (two tabs and clip).

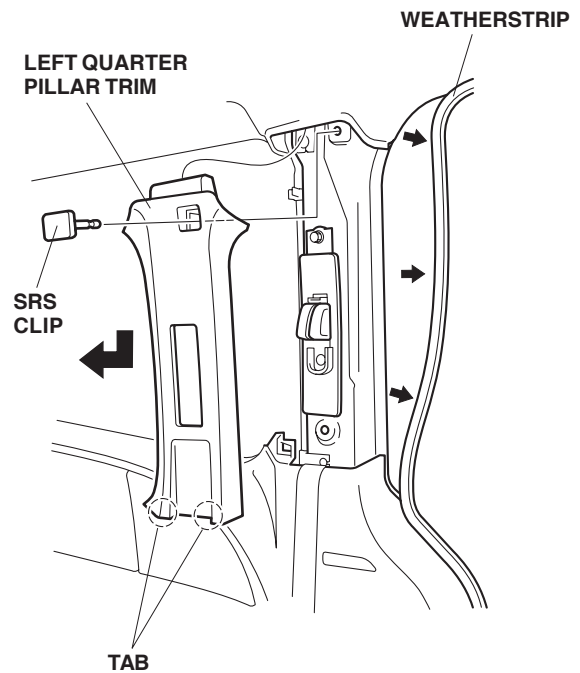

11. Remove the left rear side trim panel:

- Remove the third row seat rail cover (three clips).

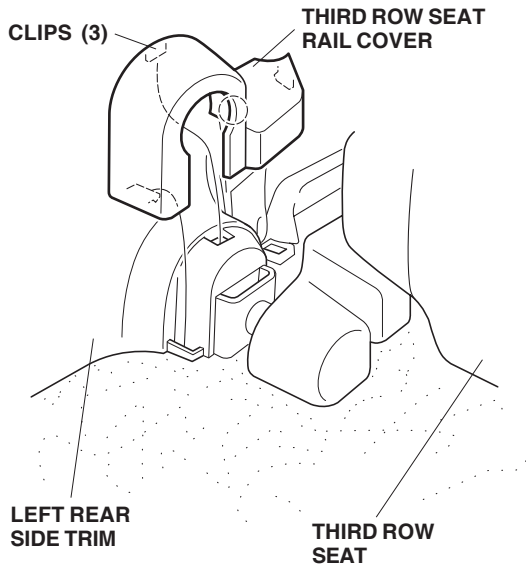

- Pull away the weatherstrip from the left rear side trim panel.
- Remove the second row seat belt lower anchor bolt.
- Gently pull the panel out towards you to release the eight clips and four retaining clips, release the third row seat belt through the slit in the panel, and disconnect the rear accessory socket connector.

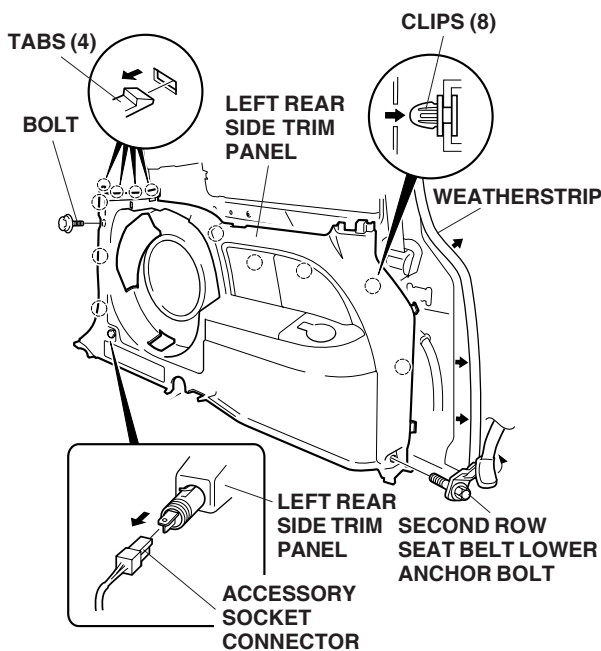

12. Remove the left rear pillar trim (one cover, one bolt, one clip, two tabs).

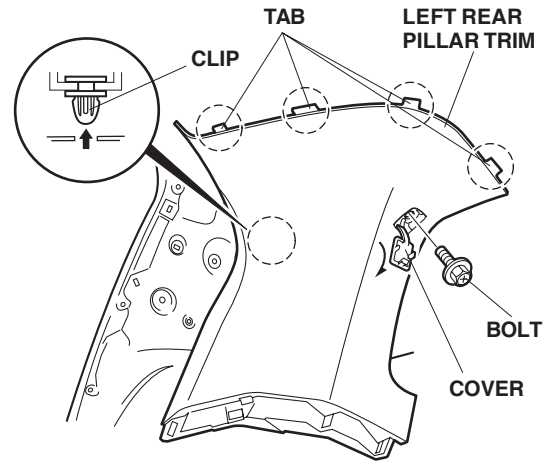

13. **EX Model Only:** Remove the two self-tapping screws, disengage the retaining tab, and pull out the power door control unit. Move the control unit out of the way.

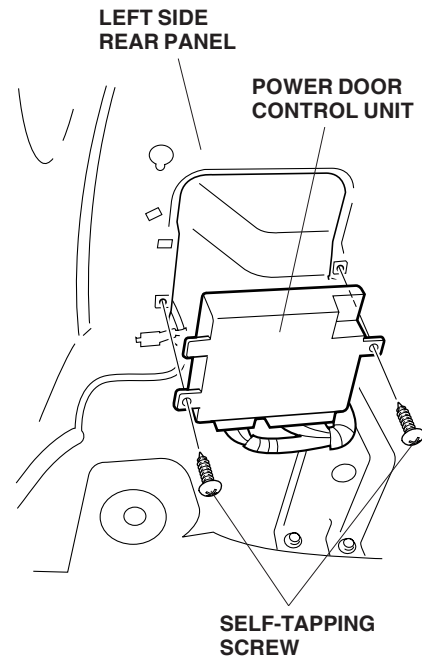

14. At the left rear panel area, enlarge the panel hole to 8 mm. While wearing eye protection, drill the body panel using an 8 mm drill bit and a drill stop.

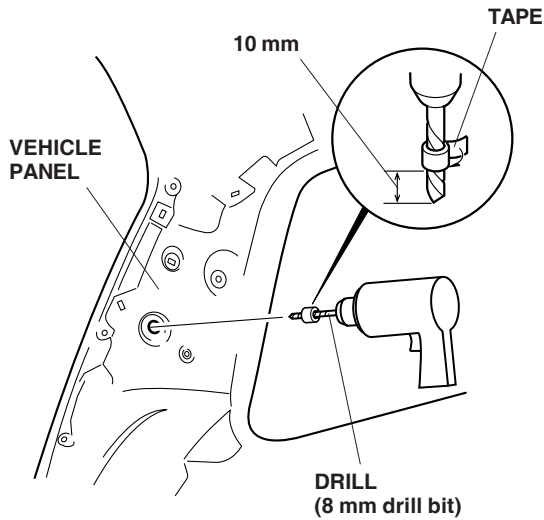

15. Install the buzzer bracket to the buzzer using the 6 x 12 mm flange bolt and a 6 mm flange nut.

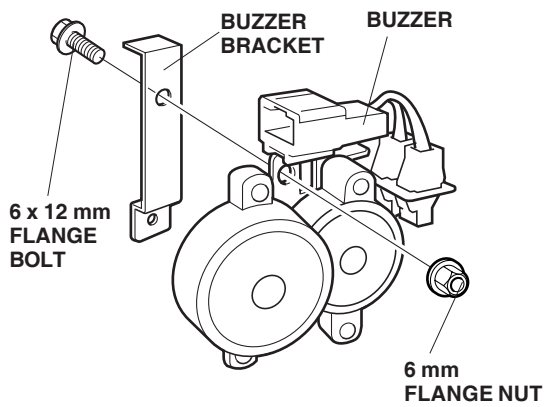

16. Using the isopropyl alcohol, thoroughly clean the areas where the cushion tape will attach. Using scissors, cut the cushion tape in half. Attach one of the two halves to the buzzer bracket.

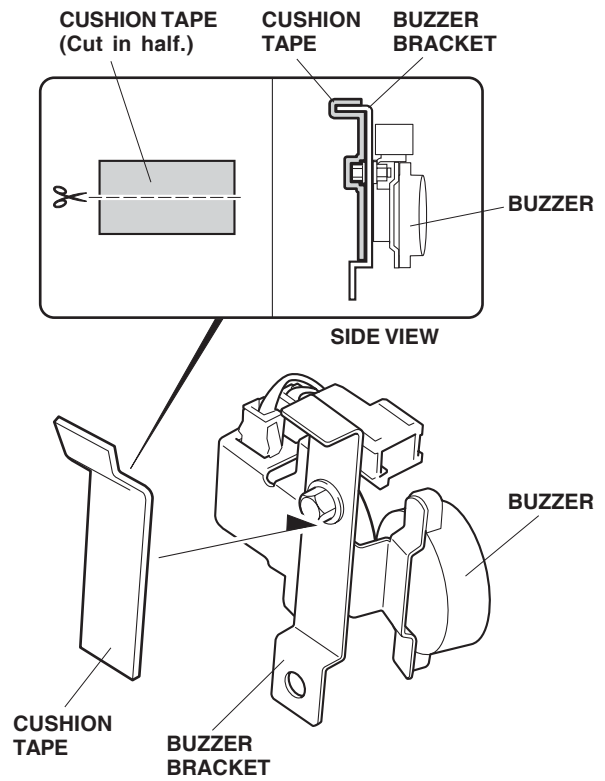

17. Install the blind nut into the 8 mm hole you drilled. Attach the buzzer to the vehicle panel using the 4 x 14 mm washer screw.

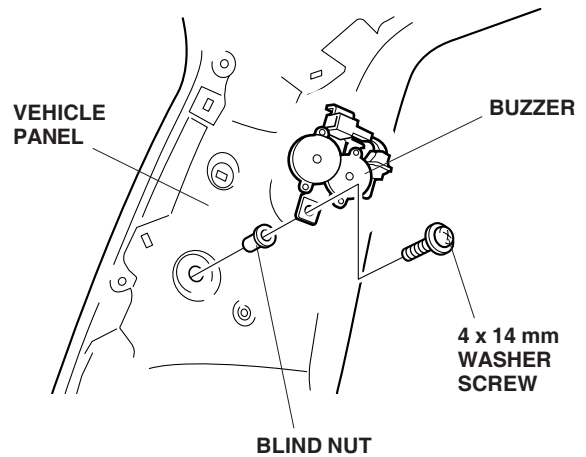

Routing the Backup Sensor Harness

- On the left rear outside of the vehicle, remove the vehicle grommet. From inside the cargo area, route the backup sensor harness out through the hole where the grommet was removed, as shown.

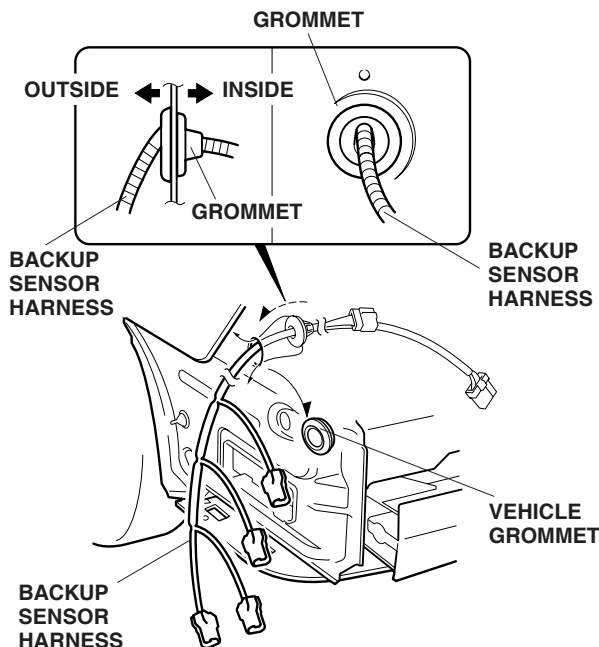

- Pull the harness grommet through the hole in the body panel, then seat the grommet in the hole.
- Route the 13-pin connector end of the backup sensor harness along the cargo area to the right rear side trim panel.

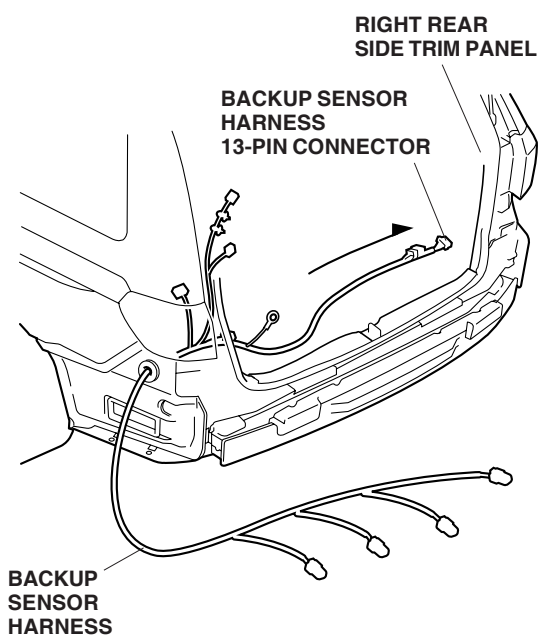

- Pull the weatherstrip away from the right rear side trim panel. Remove the one anchor screw, and gently pull out on trim panel to release the two clips.

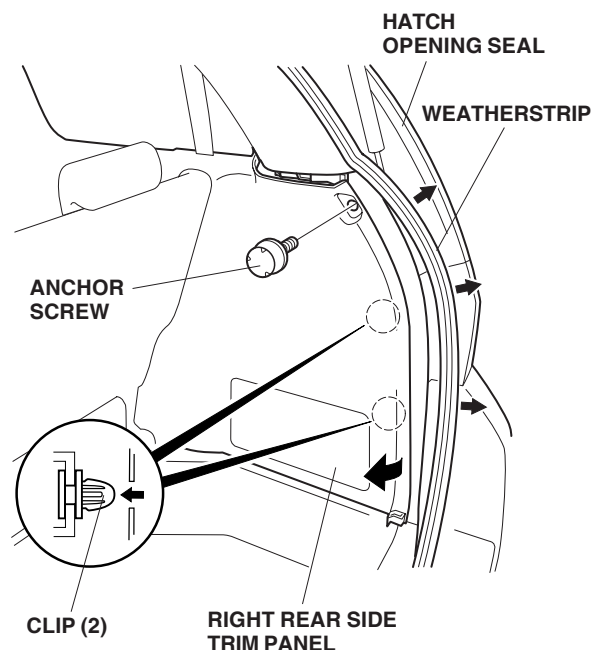

- Behind the right rear side trim panel, disconnect the 13-pin connector from the junction box. Insert the 13-pin connector from the backup sensor harness into the junction box. Plug the junction box 13-pin connector into the backup sensor harness.

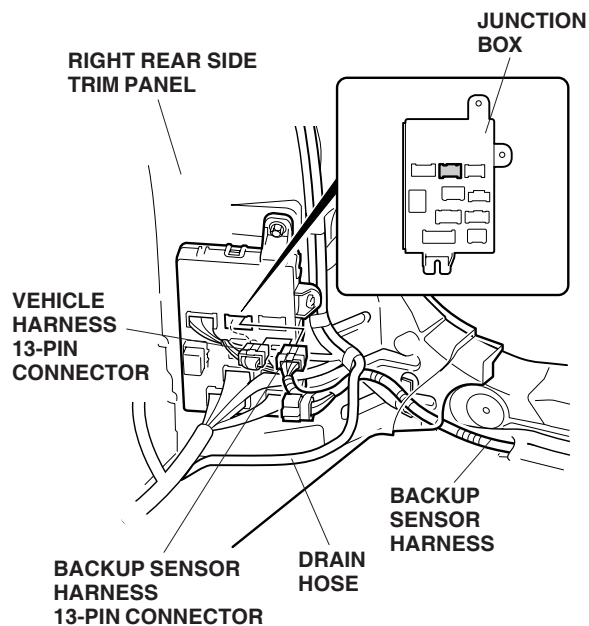

23. Route the backup sensor harness under the drain hose, and secure the backup sensor harness to the vehicle harness using two wire ties.

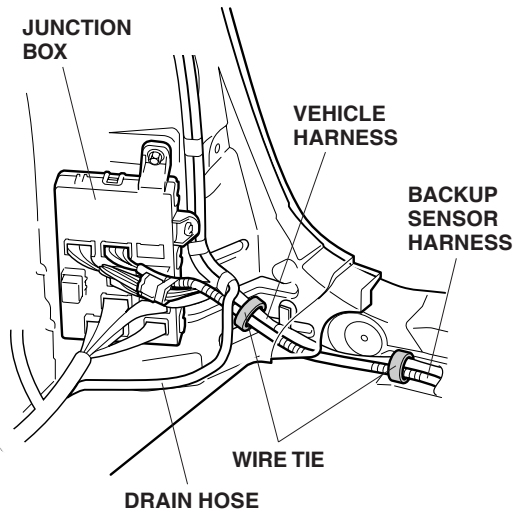

24. Secure the backup sensor harness to the vehicle harness using five wire ties.

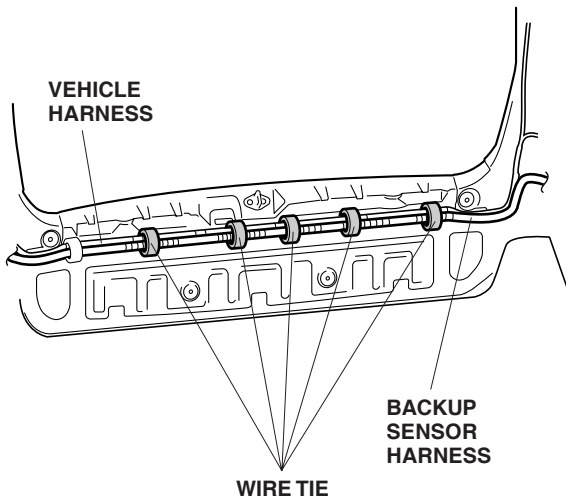

25. On the driver's side of the vehicle, attach the backup sensor harness ground terminal using the vehicle ground terminal.

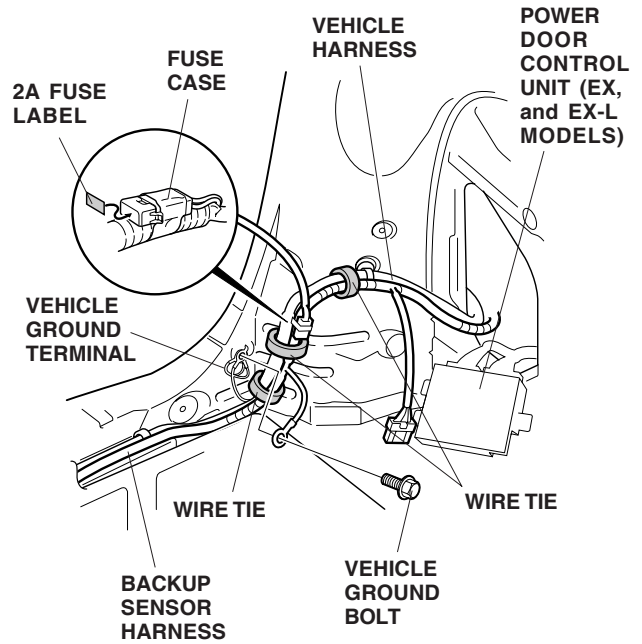

26. Install the 2A fuse label to the fuse case.

27. Secure the backup sensor harness to the vehicle harness using three wire ties.

28. Get the backup sensor control unit and the control unit bracket. Install the control unit bracket to the control unit.

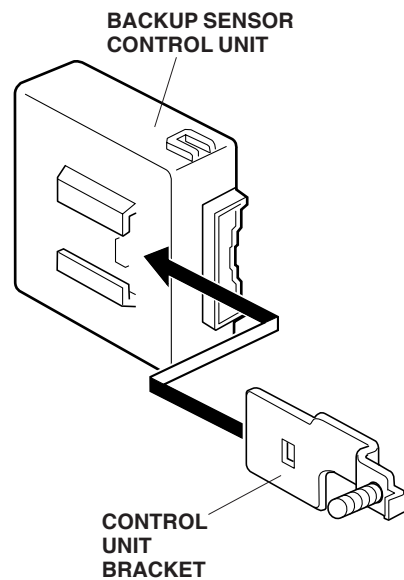

29. Plug the backup sensor harness 10-pin connector into the control unit. Attach the control unit to the inside of the left rear vehicle panel using one 6 mm flange nut.

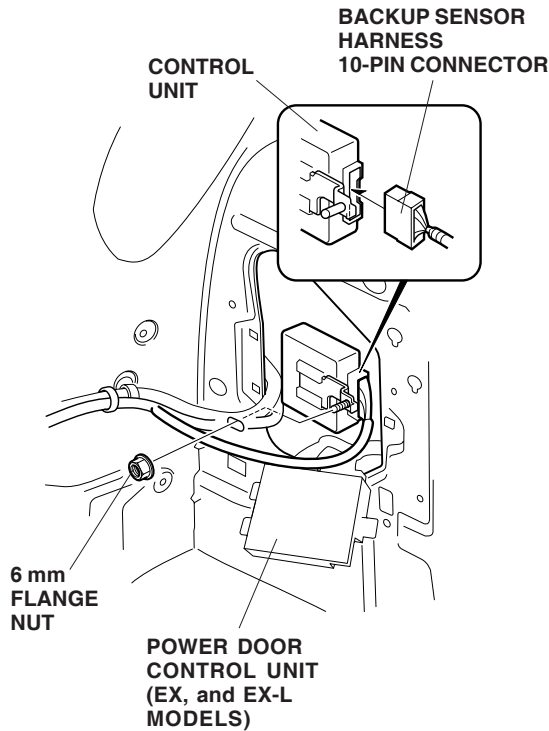

30. Secure the backup sensor to the vehicle harness using one wire tie.

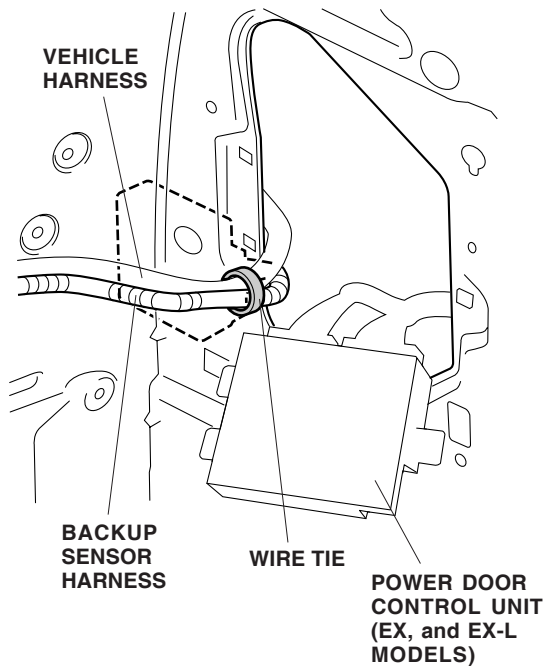

31. Plug the backup sensor harness 5-pin connector into the buzzer unit. Attach the backup sensor harness to the vehicle panel using two wire ties.

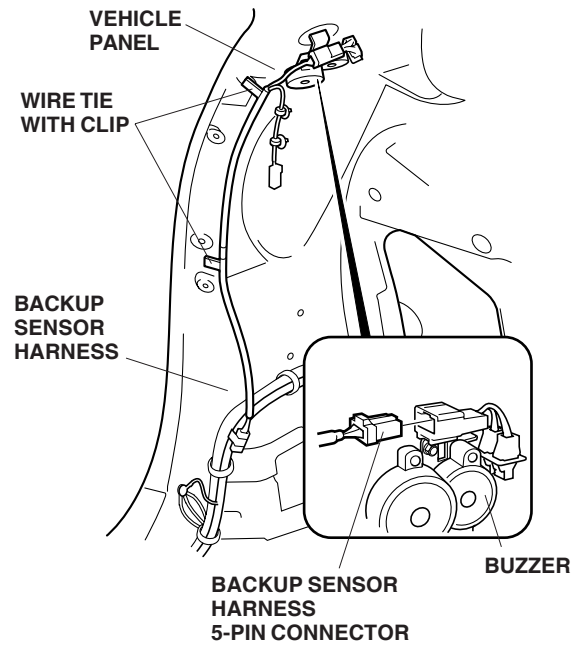

32. Install the two wire ties of the harness to the vehicle panel.

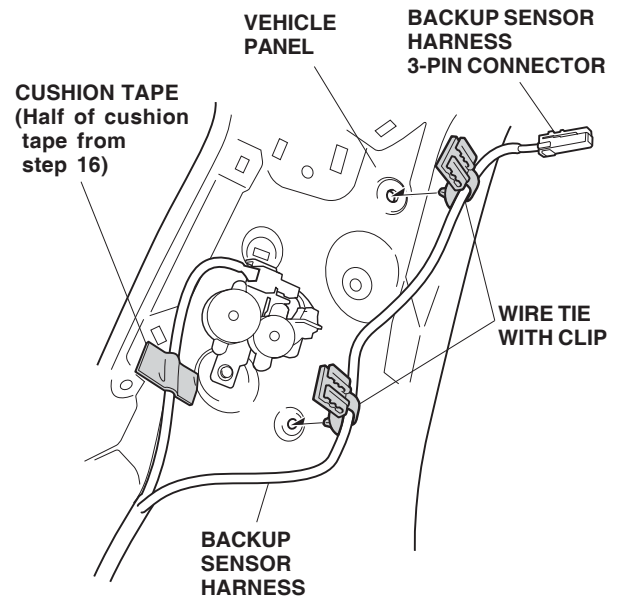

33. Using the remaining half of the cushion tape, secure the backup sensor harness to the vehicles panel.

34. Using the isopropyl alcohol, clean the areas where the cable clips will attach. On the outside of the vehicle, route the backup sensor harness across the back of the vehicle. Secure the backup sensor harness to the vehicle panel and to the bumper beam with two cable clips and two small wire ties.

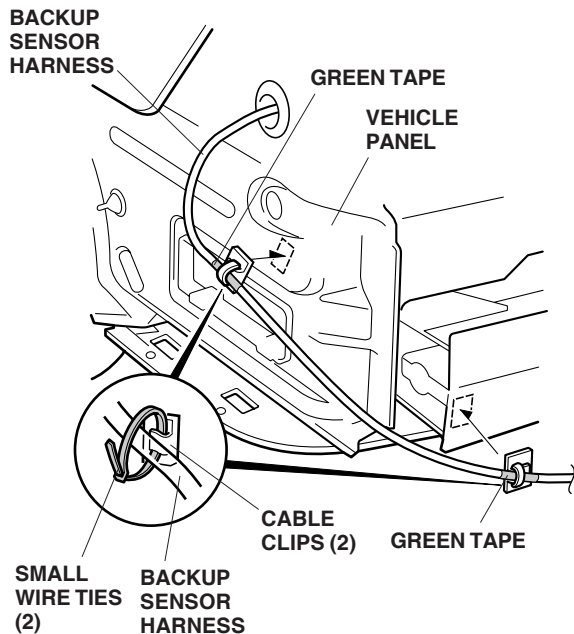

35. Using scissors, cut two EPT sealers in half. Attach one cut EPT sealer at each green tape location on the backup sensor harness.

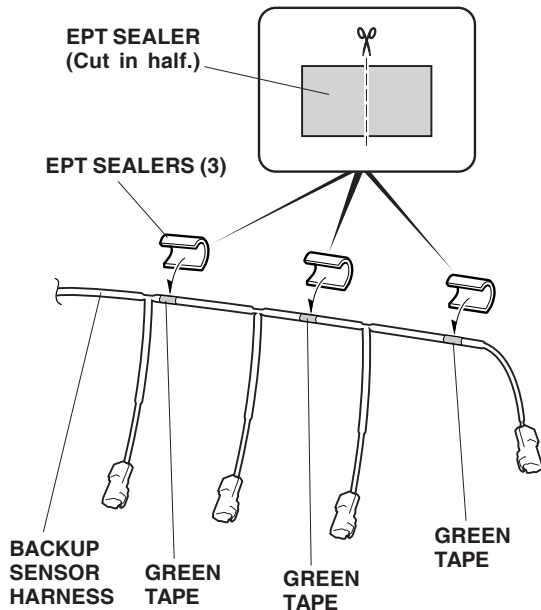

36. Remove the bumper beam support.

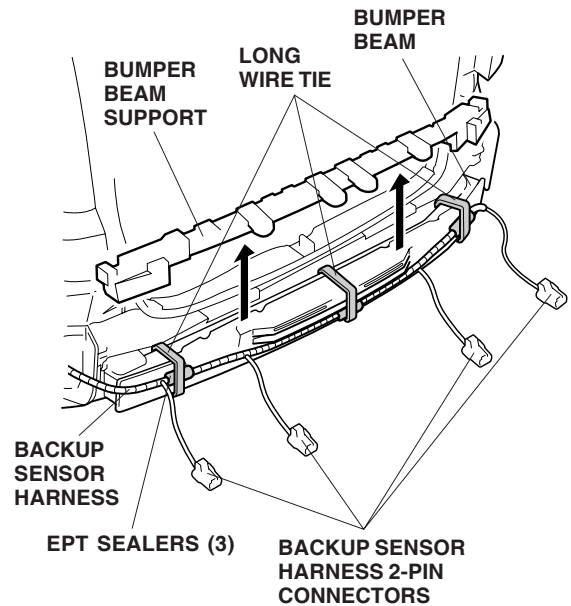

37. Route the backup sensor harness along the bumper beam. Secure the backup sensor harness to the bumper beam using three long wire ties.
38. Reinstall the bumper beam support.

Installing the Switch

39. On the inside of the left rear pillar trim, measure and mark the pillar trim at the measurements shown. Measure from the base of the ribs. While wearing eye protection, drill a 26 mm hole at the marked position.

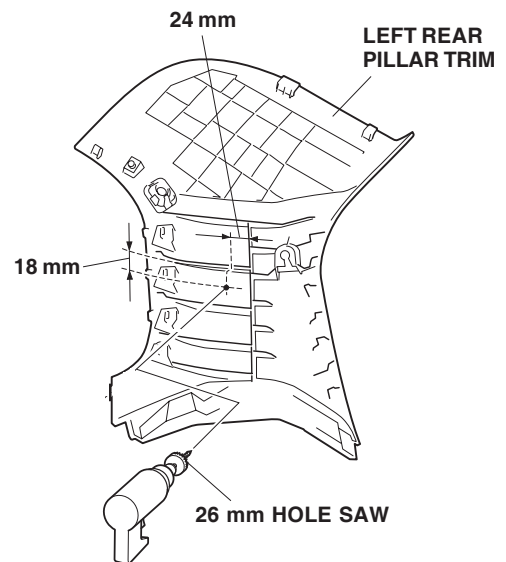

40. Install the switch into the hole in the left rear pillar trim in the direction shown.

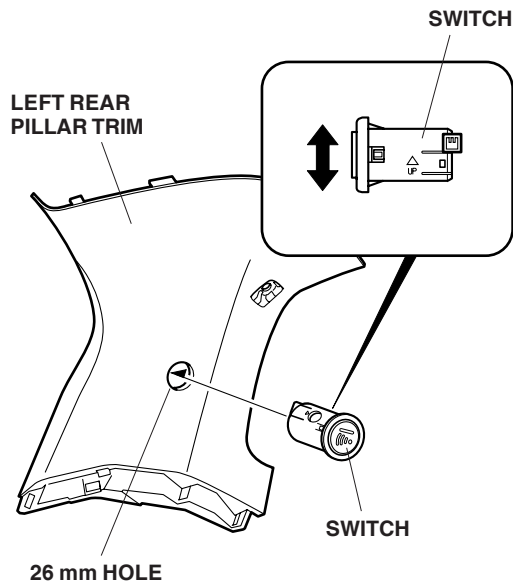

41. Plug the backup sensor harness 3-pin connector into the switch, and reinstall the left rear pillar trim.

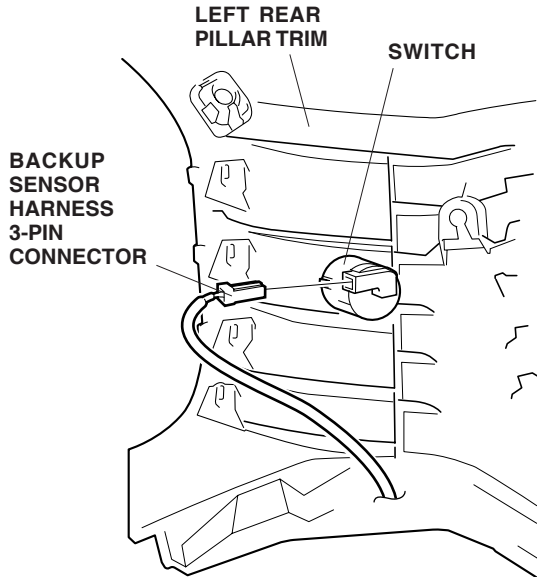

Installing the Backup Sensors

42. On the inside of the rear bumper, locate the four scribe marks. Using a pushpin, mark the bumper at each of the four locations. When you mark the bumper with a pushpin, be careful not to pierce through the other marks.

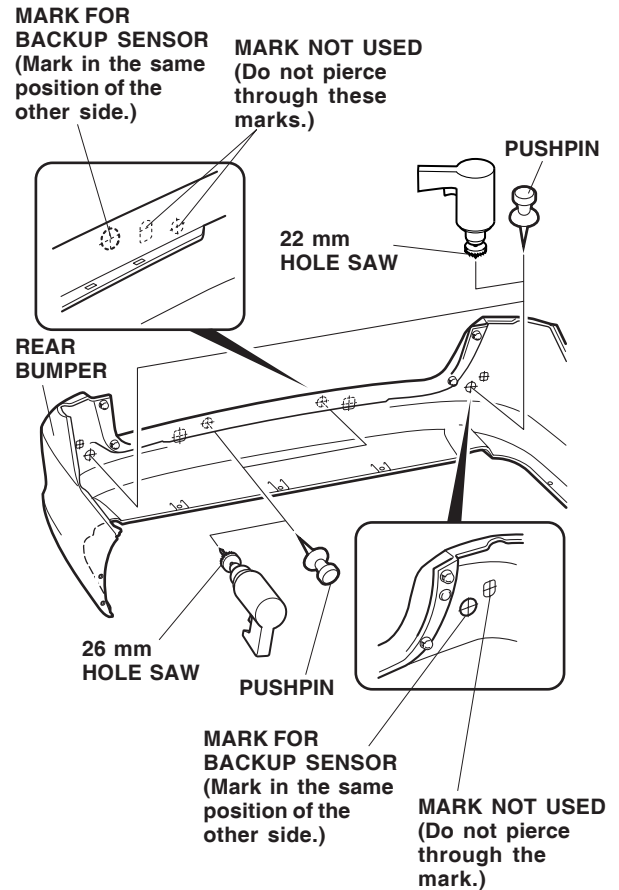

43. While wearing eye protection, drill a 22 mm hole through the outboard marks, and drill a 26 mm hole through the two inboard marks. Remove any burrs.

44. Install the two corner sensors and the two center sensors into the rear bumper with the arrow on the sensors facing up. Do not to push the microphone when installing sensors.

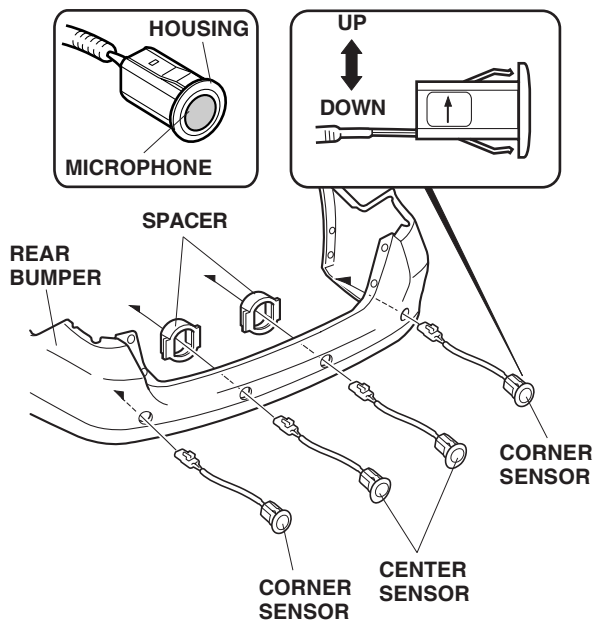

45. On the inside of the bumper, install the two spacers on the center sensors.
46. With the help of an assistant, connect the 2-pin connectors from the backup sensor harness to the sensors, then reinstall the bumper.

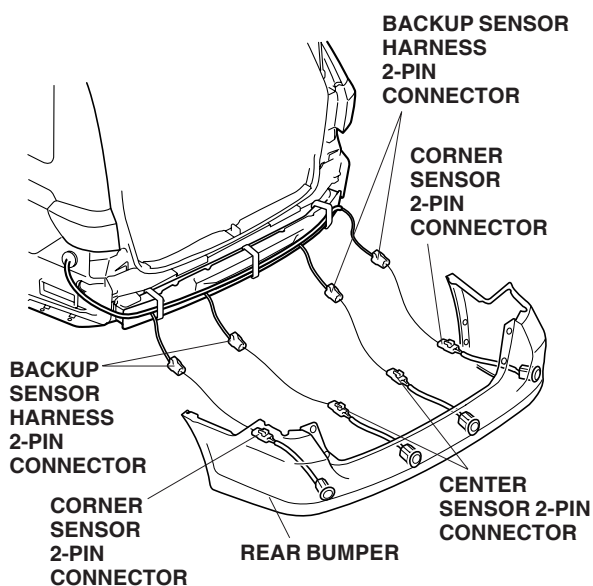

47. Check that all wire harnesses are routed properly, and that all connectors are plugged in.
 48. Reinstall all removed parts.
 49. Reconnect the negative cable to the battery.
 50. Enter the customer's radio anti-theft code, and reset the radio station presets.
 51. Reset the clock.
 52. Check the operation of the backup sensors as described in the backup sensor owner's manual supplied.
- NOTE:** Whenever the battery is disconnected, the driver's AUTO function is disabled.
53. Start the engine. Push down on the driver's window switch until the window is fully open, then hold the switch for 2 seconds or more.
 54. Pull up on the driver's window switch to close the window completely.
 55. Test the driver's AUTO window function.