



# INSTALLATION INSTRUCTIONS

Accessory	Application	Publications No.
<b>AUTOMATIC DAY/NIGHT MIRROR</b>	<b>2005 ODYSSEY</b>	<b>All 27335-27953</b>
		Issue Date
		<b>OCT 2004</b>

## PARTS LIST

### Automatic Day/Night Mirror Kit P/N 08V03-S9A-100B

Day/Night mirror

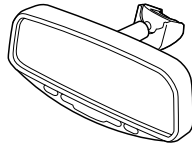

Owner's Manual

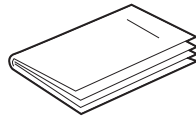

### Automatic Day/Night Mirror Attachment Kit P/N 08V03-SJA-101

Wire cover

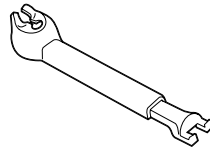

Mirror harness

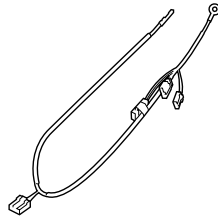

Subharness

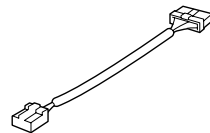

9 Wire ties

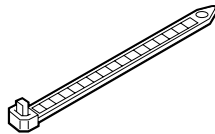

4 EPT seals

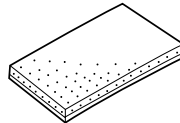

5 Cushion tapes

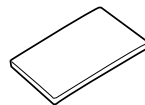

Ground bolt



## TOOLS AND SUPPLIES REQUIRED

Phillips screwdriver

Flat-tip screwdriver

8 mm Socket

Ratchet

Tape measure

T20 Torx bit

Isopropyl alcohol

Shop towel

Clip remover

## Illustration of the Day/Night Mirror Installed on the vehicle

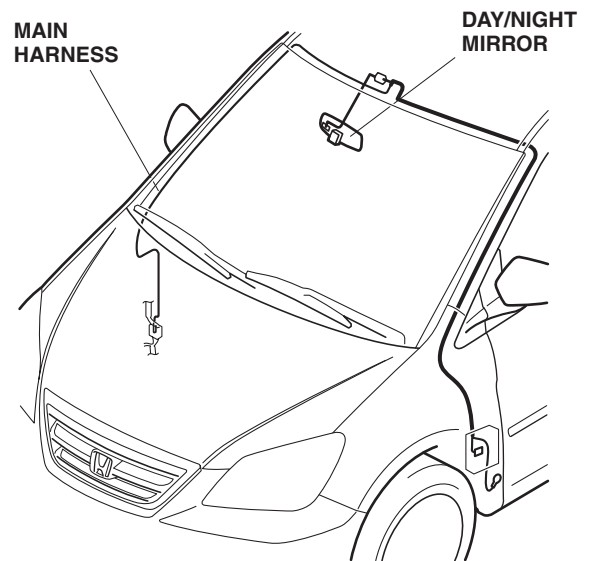

## INSTALLATION

**Customer Information:** The information in this installation instruction is intended for use only by skilled technicians who have the proper tools, equipment, and training to correctly and safely add equipment to your vehicle. These procedures should not be attempted by "do-it-yourselfers."

1. Make sure you have the anti-theft code for the radio, then write down the radio station presets.
2. Disconnect the negative cable from the battery.

- Remove the mirror by lifting it up out of the mirror base.

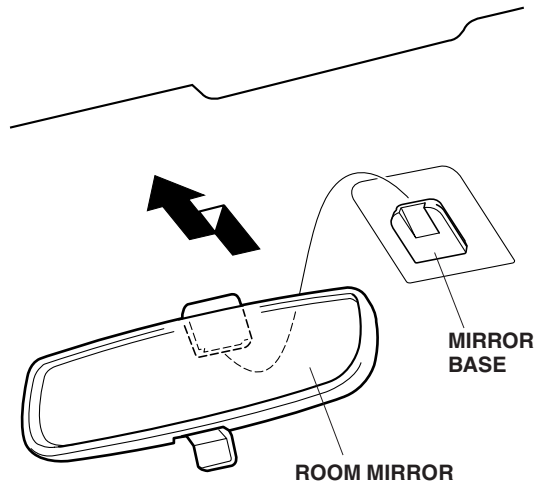

- Remove the right and left map light lens (four tabs for each lens).
- Remove the two 5 mm bolts, ground bolts and pull out the room light.

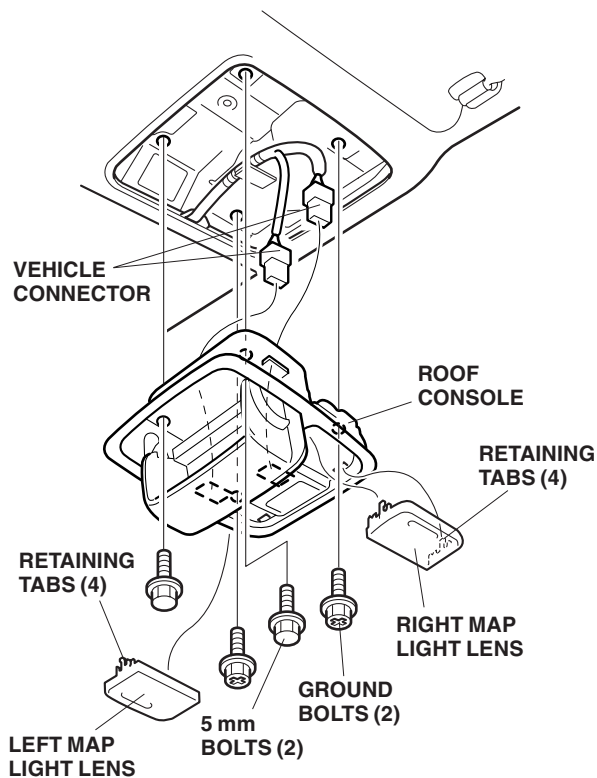

- Disconnect the two vehicle connectors and remove the room light case. LX model has only one connector.

- Remove the two retaining tabs and remove the cover from the left sunvisor.

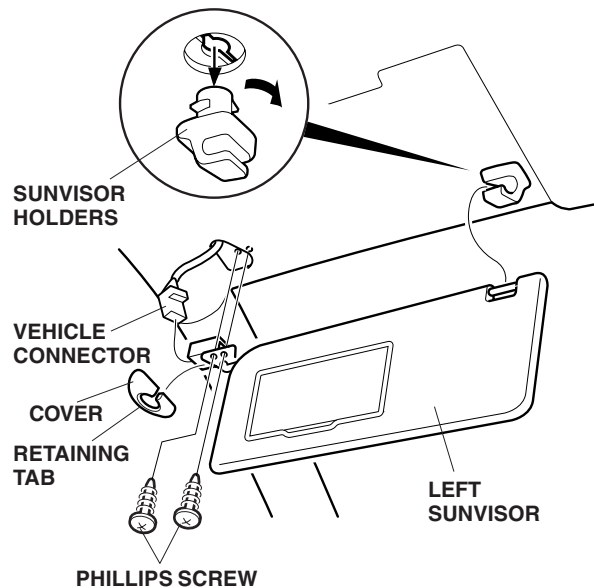

- Remove the two phillips screws, pull out the left sun visor, disconnect the vehicle connector, and remove the sunvisor.
- Repeat steps 7 and 8 to remove the right sunvisor.
- Remove the right and left sunvisor holders.
- Remove the door opening trim from around the left front "A" pillar trim. Remove the left front "A" pillar (two clips).

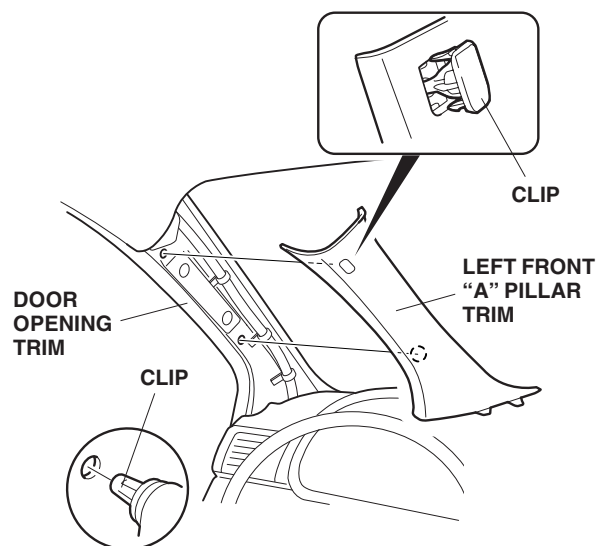

- Remove the right front "A" pillar the same way.

13. Remove the left front door sill trim (three clips).

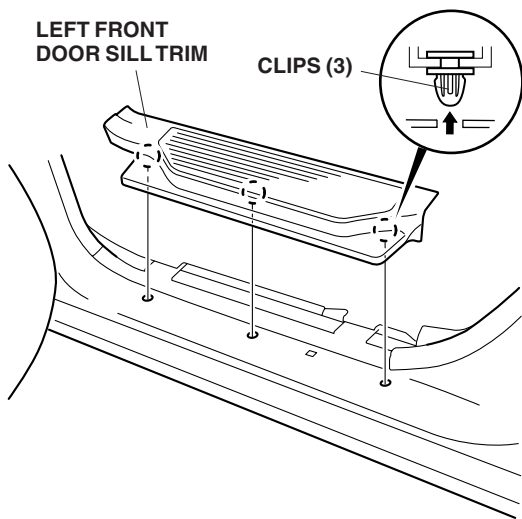

14. Remove the right front door sill trim (three clips).

15. Pull out the door opening trim at the left kick panel. Remove the left kick panel (three clips).

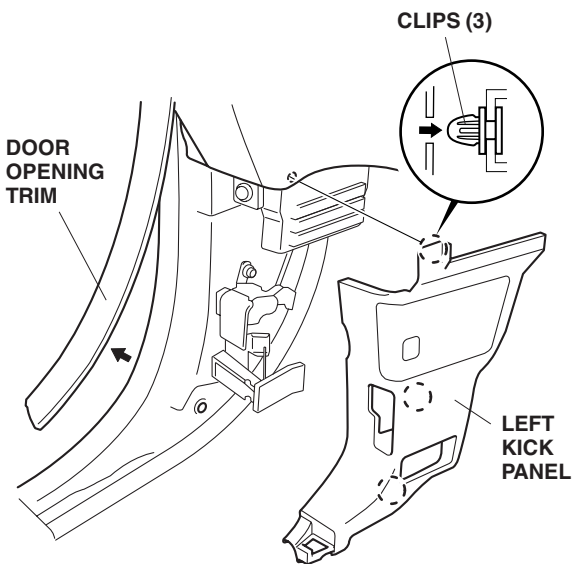

16. Remove the right kick panel the same way.

17. Remove the damper arm cover and disconnect the arm.

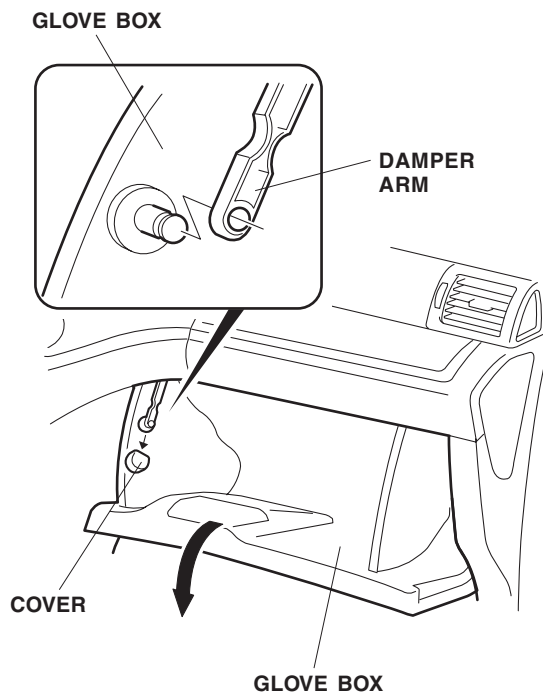

18. Open the glove box. Remove the two stoppers by releasing the two retaining tabs for each stopper. Remove the glove box (two screws). Remove cover and rod.

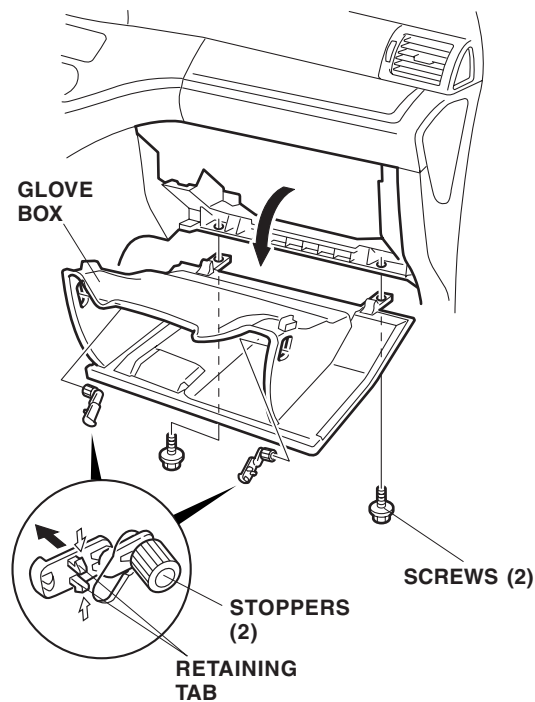

19. Get the automatic day/night mirror, and the subharness. Plug the 7-pin connector from the subharness into the mirror.
20. Install the mirror to the mirror base.

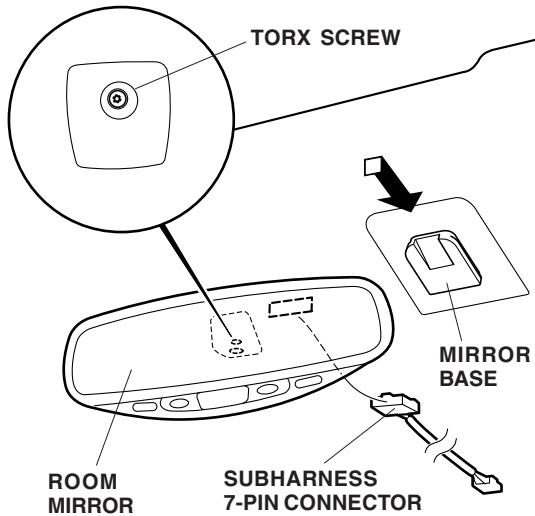

21. Secure the automatic day/night mirror to the mirror base by tightening the torx screw.
22. Route the subharness up to the headliner and pull it out through the console opening.

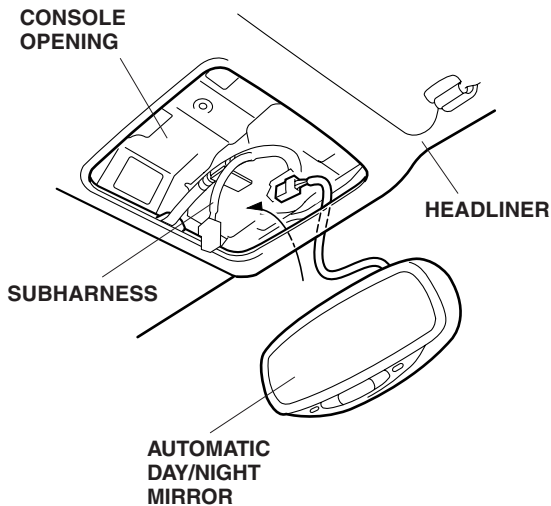

### Routing the Mirror Harness

23. Get the mirror harness, plug the subharness connector into the mirror harness connector. Be careful not to plug in the subharness into the roof console connector.

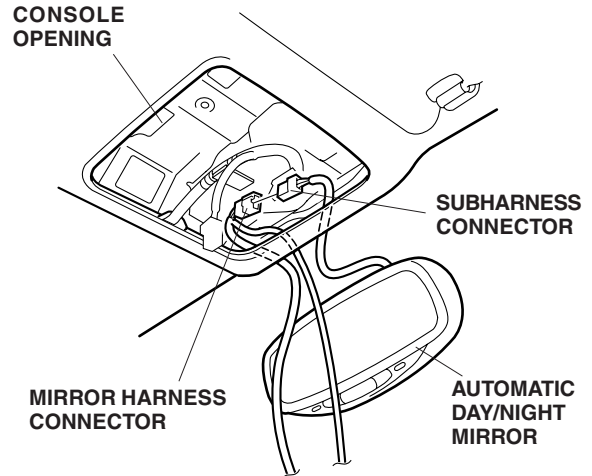

24. Attach the mirror harness connector to the vehicle panel with one EPT sealer as far forward as possible.

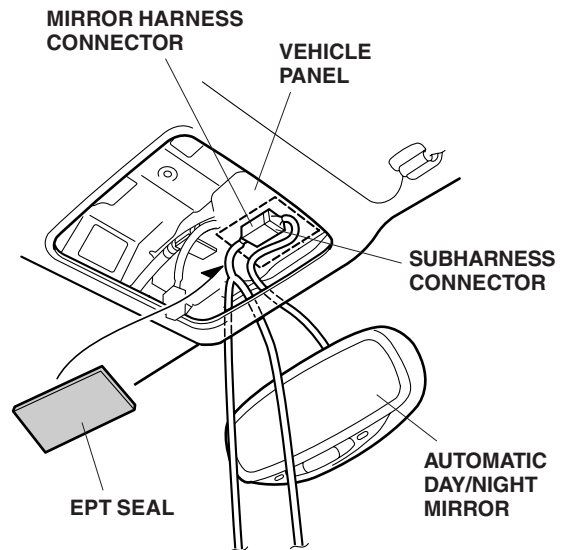

25. Route the terminal from the mirror harness under the headliner toward the right side of the vehicle.

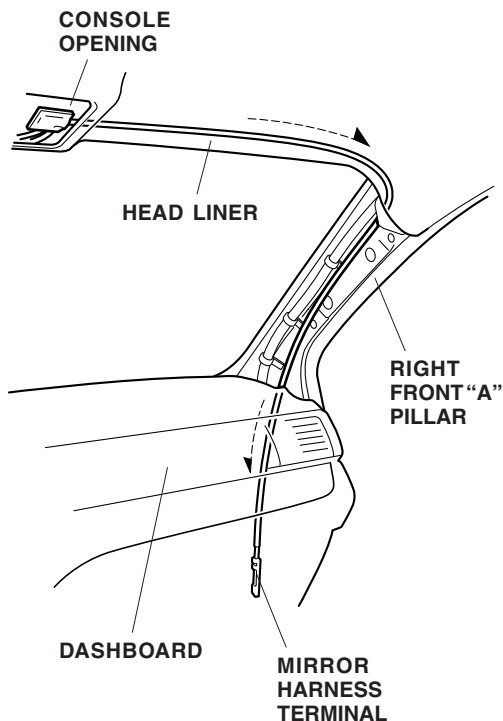

26. Continue routing the mirror harness down the "A" pillar and behind the dashboard.
27. Locate the 22-pin connector below the dashboard at the kick panel area. Disconnect the vehicle 22-pin connector, unlock the connector terminal pin lock, and insert the mirror harness terminal into the vehicle 22-pin connector at the location shown. Reconnect the 22-pin connector.

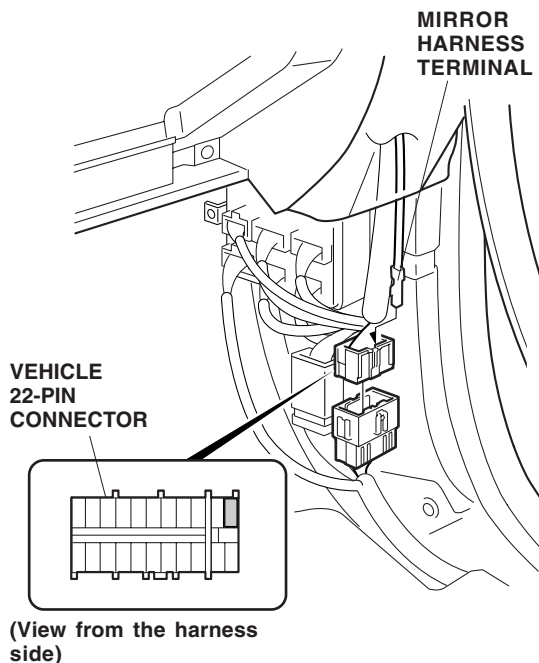

28. Secure the mirror harness to the vehicle harness using three wire ties.

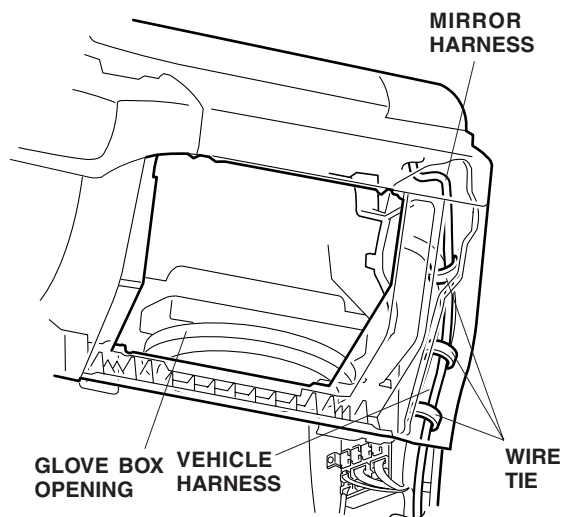

29. Using isopropyl alcohol on a shop towel, clean the right front "A" pillar area where the mirror harness will attach. Attach the mirror harness to the right front pillar using four cushion tapes.

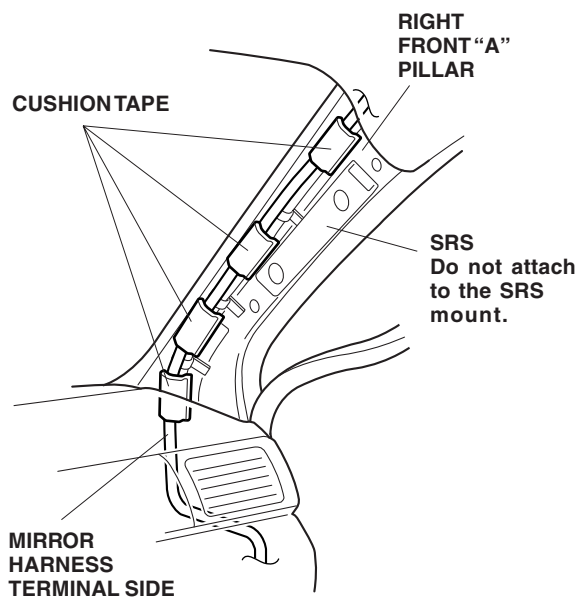

30. Using isopropyl alcohol on a shop towel, clean the headliner area where the mirror harness will attach. Using scissors, cut two EPT sealers in half. Using three halves of EPT sealers, attach the mirror harness to the vehicle panel.

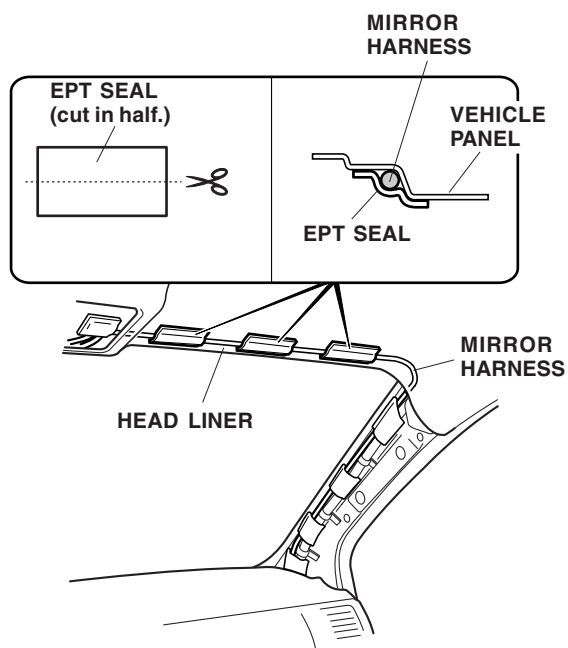

31. Route the ground terminal end from the mirror harness along the headliner and down the left front "A" pillar towards the left fuse box.

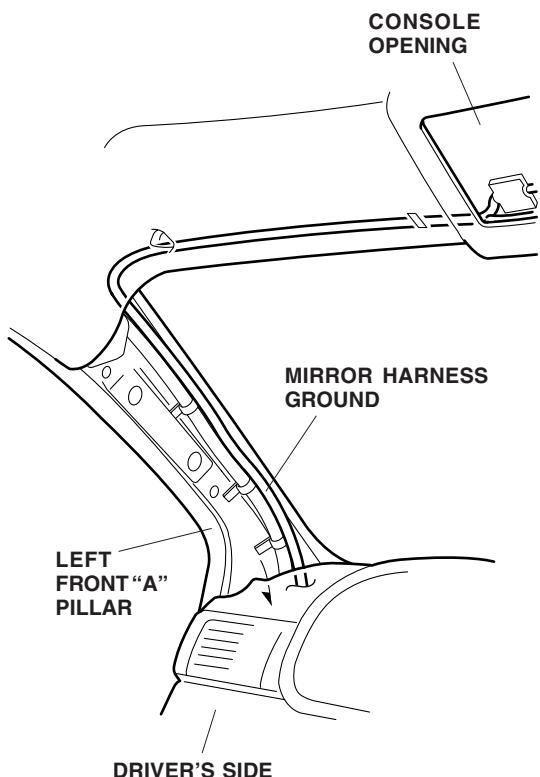

32. Plug the mirror harness 6-pin connector into the 6-pin opening in the fuse box.

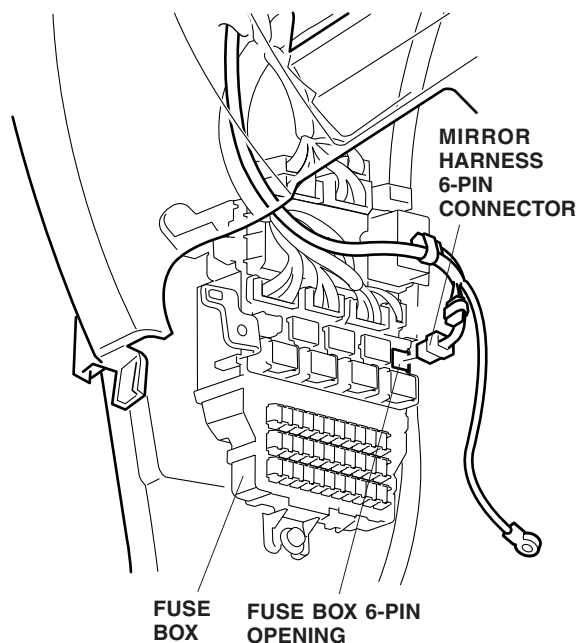

NOTE: If another accessory is already plugged into the 6-pin connector, remove the dummy connector from the 6-pin connector taped to the day/night harness. Plug the 6-pin connector from the other accessory harness into the 6-pin connector from the day/night harness you just unplugged and plug the day/night harness into the fuse box.

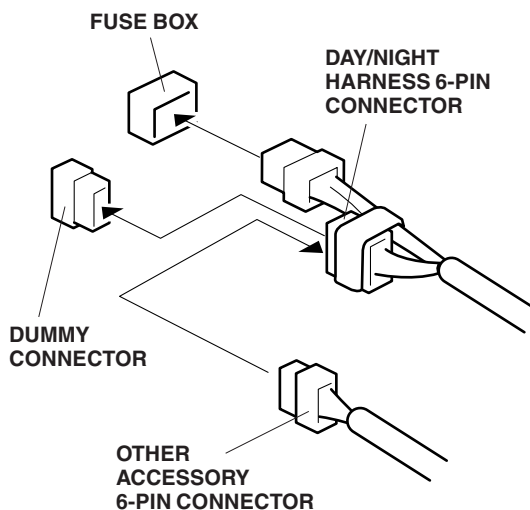

33. Remove the bolt from the fuel lid opener. Attach the ground terminal from the mirror harness, and reinstall the fuel lid opener using the ground bolt supplied.

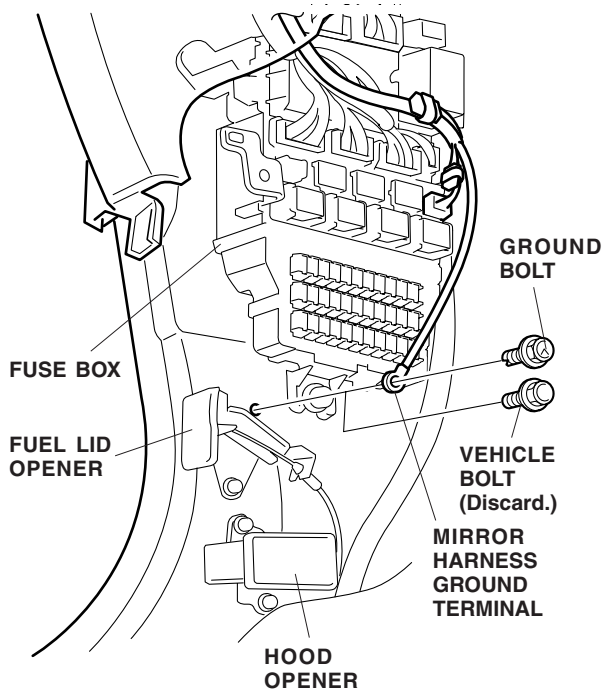

34. Secure the mirror harness to the vehicle harness using two wire ties.

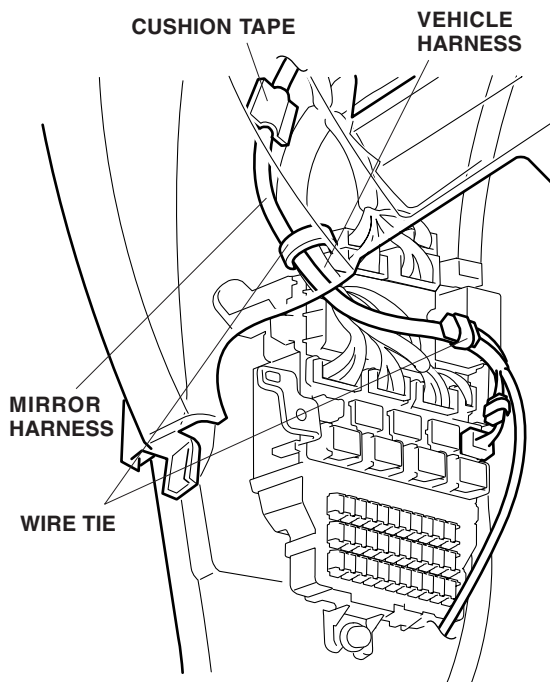

35. Using isopropyl alcohol on a shop towel, clean the vehicle panel. Attach the mirror harness to the vehicle panel using one cushion tape.
36. Along the left front "A" pillar area, secure the mirror harness to the vehicle harness using four wire ties.

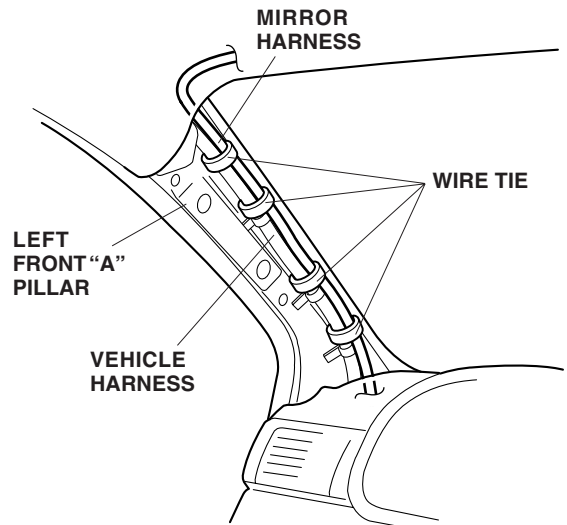

37. Using scissors, cut one EPT sealer in half, using isopropyl alcohol on a shop towel, clean the headliner area. Secure the mirror harness to the headliner using three pieces of EPT sealer (one piece was cut in step 30).

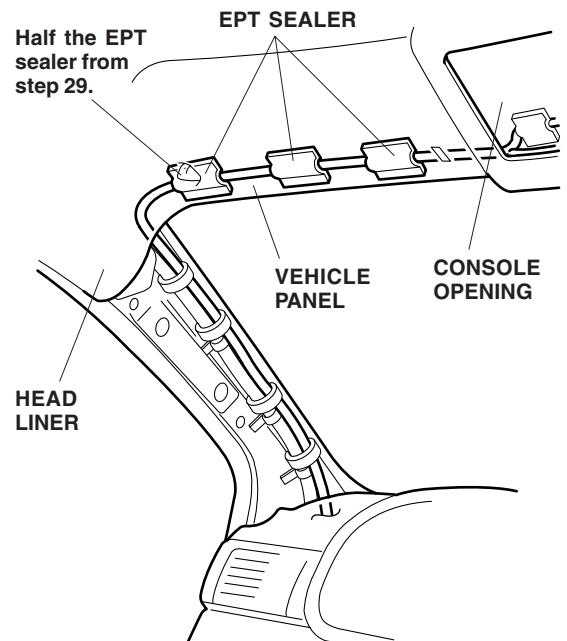

38. Install the wire cover from the mirror to the headliner.

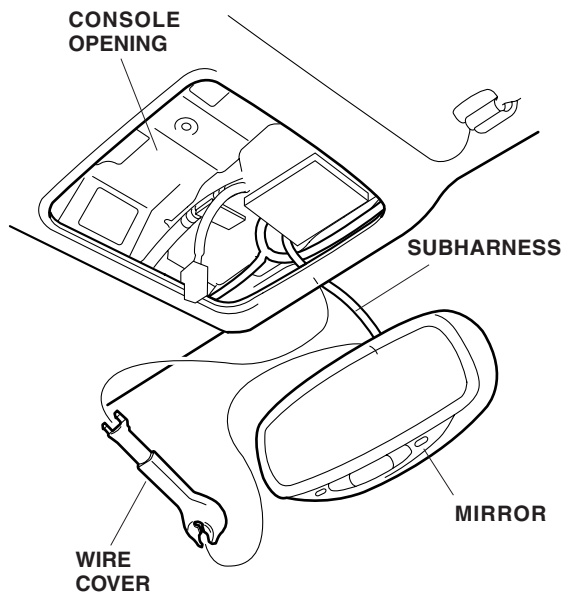

39. Reinstall all removed parts.
40. Reconnect the negative cable to the battery.
41. Enter the customer's radio anti-theft code, and reset the radio station presets.
42. Reset the clock.
43. If equipped check the operation of the satellite radio according to the vehicle's Owner's Manual.

NOTE: Whenever the battery is disconnected, the driver's AUTO function is disabled.

44. Start the engine. Push down on the driver's window switch until the window is fully open.
45. Pull up on the driver's window switch to close the window completely, then hold the switch for 2 seconds or more.
46. Test the AUTO window function.