



# INSTALLATION INSTRUCTIONS

Accessory

TWEETER KIT  
P/N 08A55-S9A-100

Application

2005 CR-V

Publications No.

All 27197

Issue Date

SEP 2004

## PARTS LIST

2 Tweeters

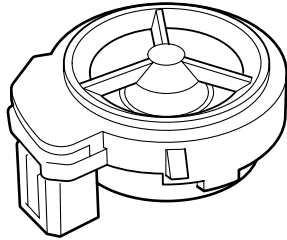

Right tweeter harness  
(marked "AS")

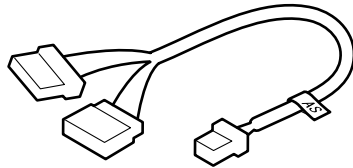

Left tweeter harness  
(marked "DR")

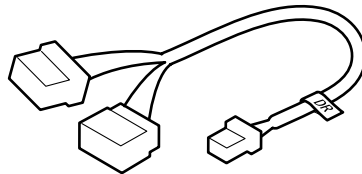

8 Wire ties

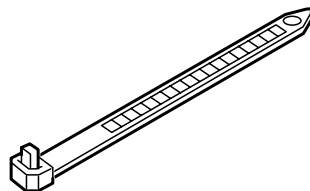

## TOOLS AND SUPPLIES REQUIRED

- Phillips screwdriver
- Flat-tip screwdriver
- Small flat-tip screwdriver
- Piece of wire
- Electrical tape
- Masking tape

## INSTALLATION

**Customer Information:** The information in this installation instruction is intended for use only by skilled technicians who have the proper tools, equipment, and training to correctly and safely add equipment to your vehicle. These procedures should not be attempted by "do-it-yourselfers."

1. Make sure you have the anti-theft code for the radio, then write down the radio station presets.
2. Disconnect the negative cable from the battery.
3. Remove the passenger's dashboard under cover (release the three clips and two pins).

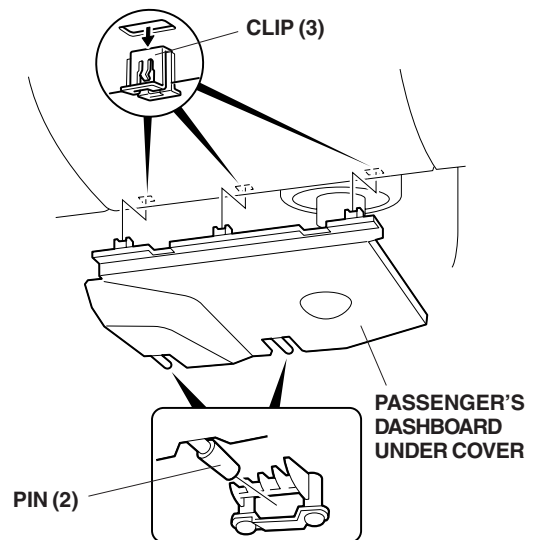

4. Open the glove box. Release the right and left stops.

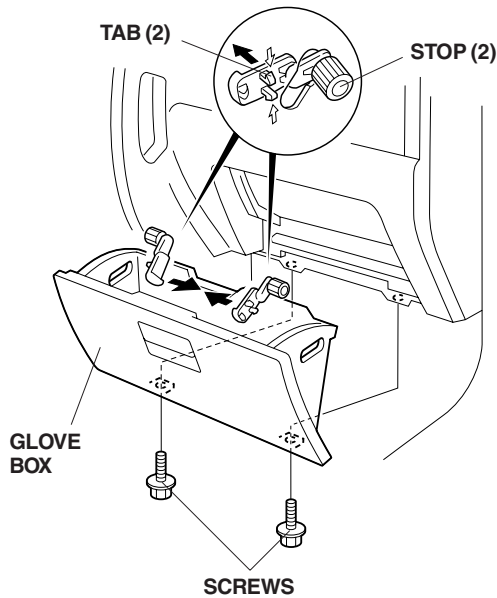

5. Remove the two screws from the bottom of the glove box, and remove the glove box.
6. Remove the driver's dashboard under cover (turn the knob 90° clockwise, and release the retaining clip).

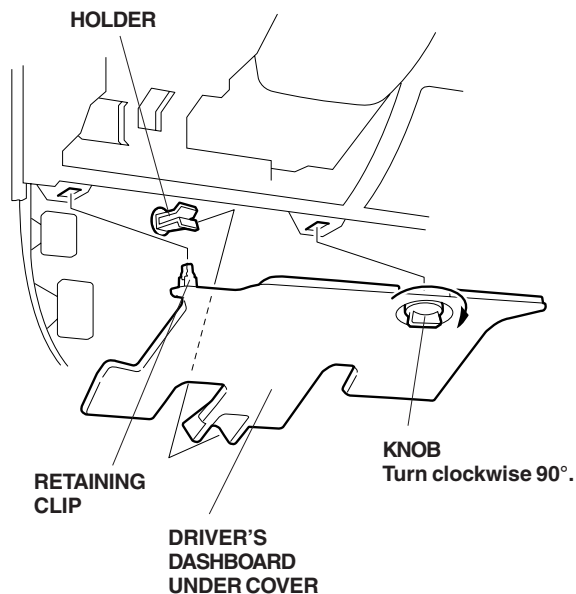

7. Apply masking tape to the left front pillar and the dashboard along the edges of the tweeter cover. Release the retaining clips with a small flat-tip screwdriver wrapped with a shop towel. Pry up on the tweeter cover to remove it. Take care not to damage the clip and retaining tabs.

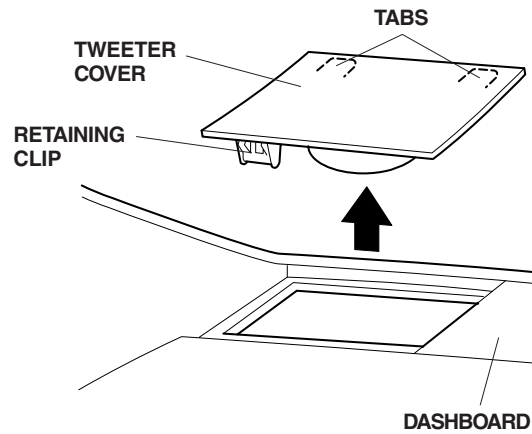

8. Remove the tweeter cover from the right side of the vehicle using the above procedure.

- Remove the left kick panel (pull to release the two clips).

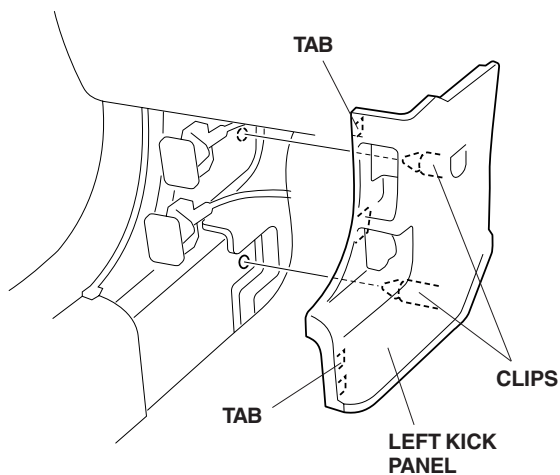

- Remove the right kick panel (pull to release the two clips).

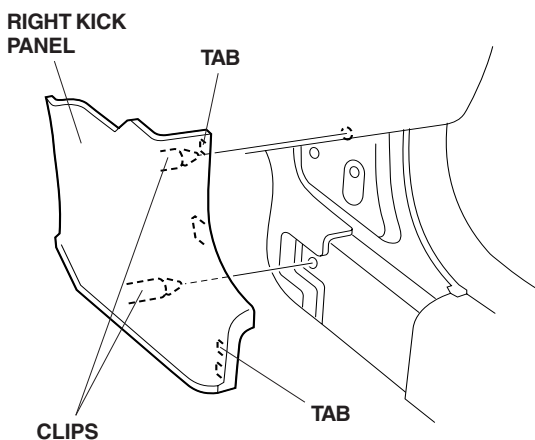

### Routing the Left Tweeter Harness

- While wearing gloves, locate and unplug the vehicle 13-pin connector (white) under the dashboard on the driver's side of the vehicle.

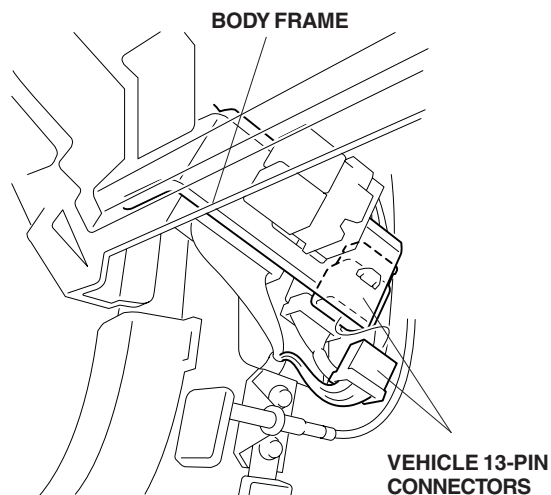

- Get the left tweeter harness from the kit. Route a piece of wire down from the tweeter cover opening to the floor, and tape the 2-pin connector to the wire.

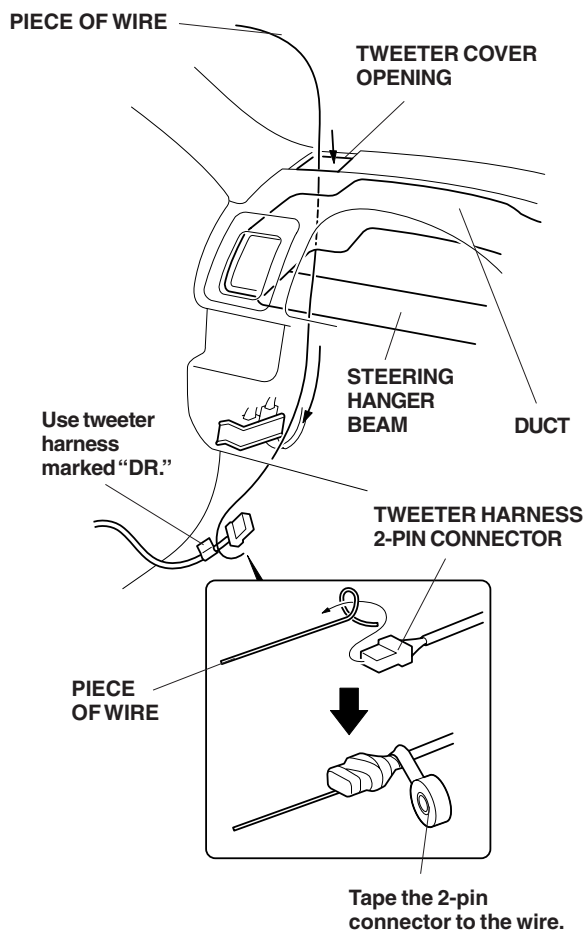

- Pull the left tweeter harness 2-pin connector up from the floor to the tweeter cover opening.

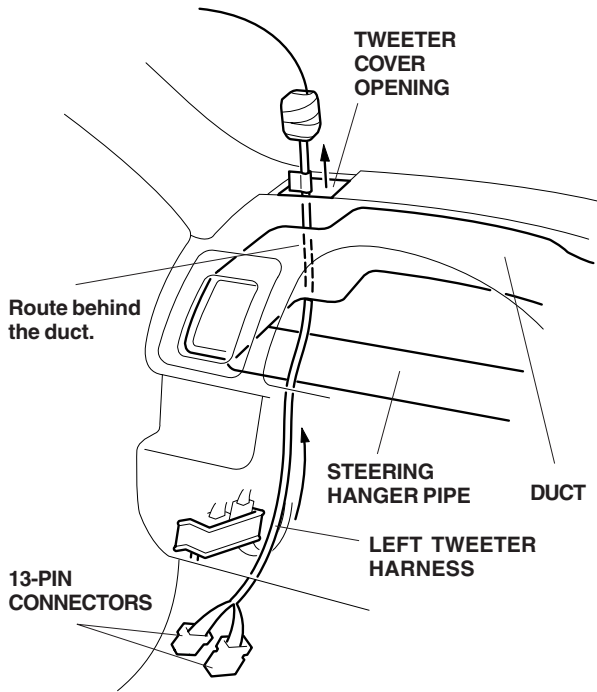

- Remove the wire from the 2-pin connector. To prevent the tweeter harness from falling, tape it to the dashboard.
- Plug the two left tweeter harness 13-pin connectors into the vehicle 13-pin connectors that you unplugged in step 11.

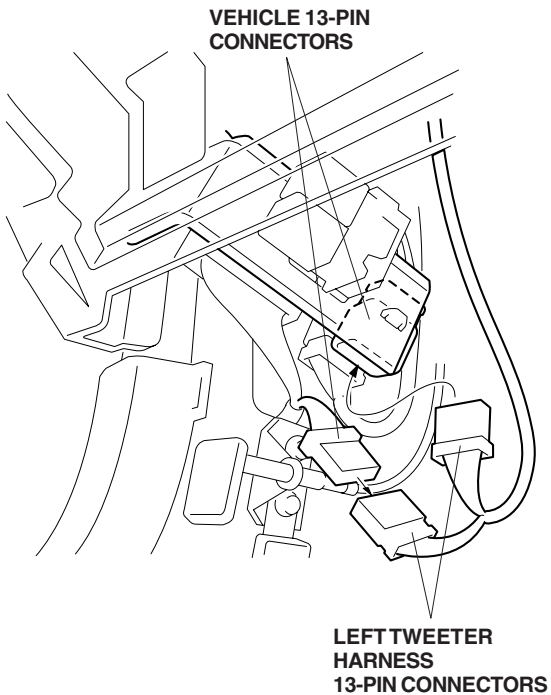

- Get one tweeter from the kit. Install the tweeter on the back of the tweeter cover by engaging the three tabs with the square holes in the tweeter cover.

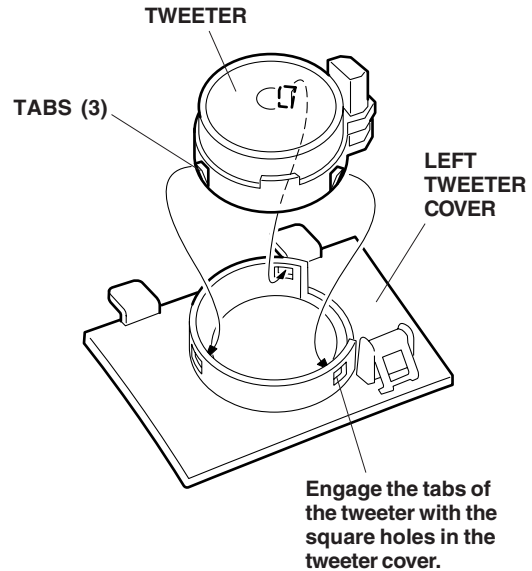

- Plug the left tweeter harness 2-pin connector into the tweeter 2-pin connector, then reinstall the tweeter cover.

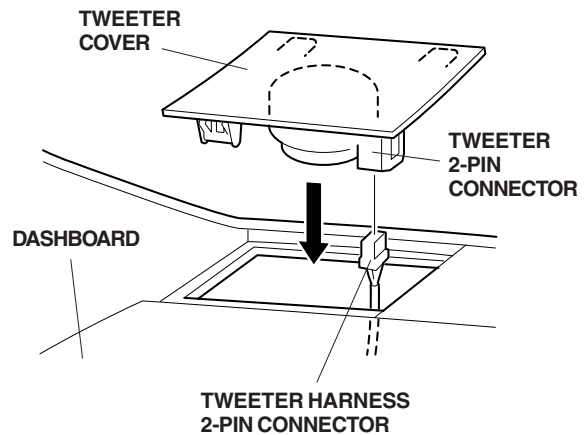

- Slide the left tweeter harness 13-pin connector into the vehicle connector clip. Make a loop in the left tweeter harness, and secure it to the vehicle harness with three wire ties in the areas shown.

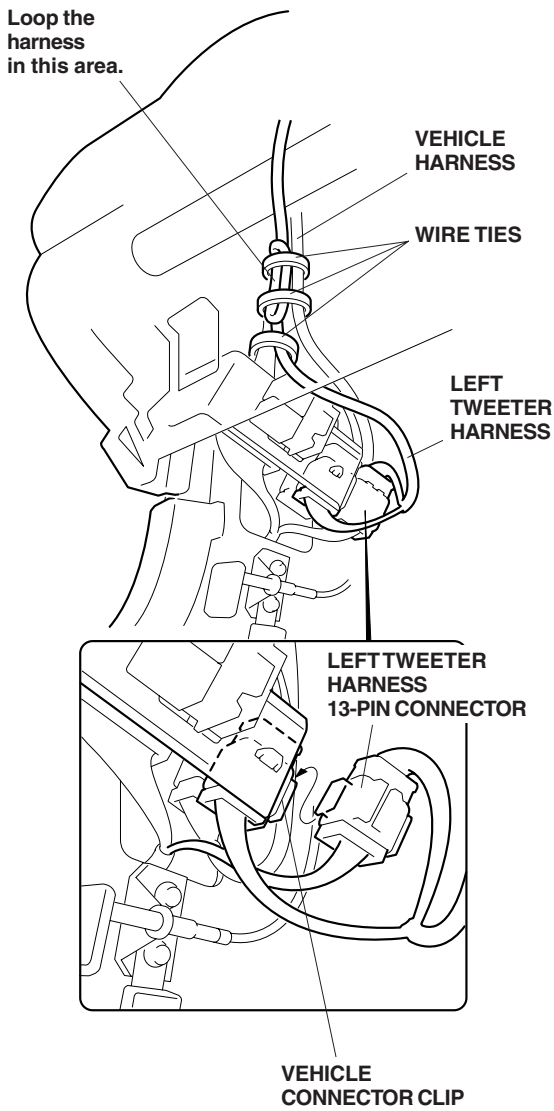

### Routing the Right Tweeter Harness

- Inside the glove box opening, locate and unplug the vehicle 13-pin connector (white) under the dashboard.

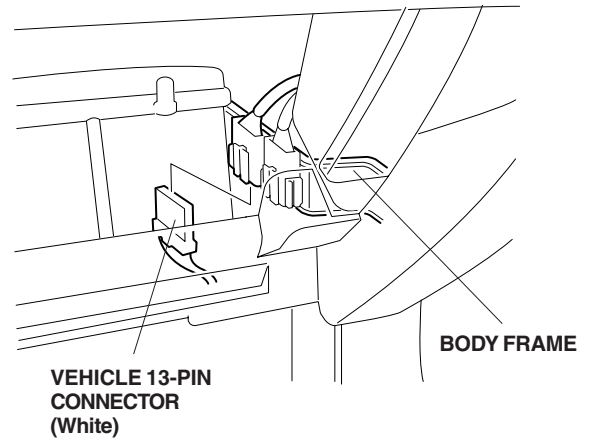

- Get the right tweeter harness from the kit. Route a piece of wire down from the tweeter cover opening to the floor, and tape the 2-pin connector to the wire.

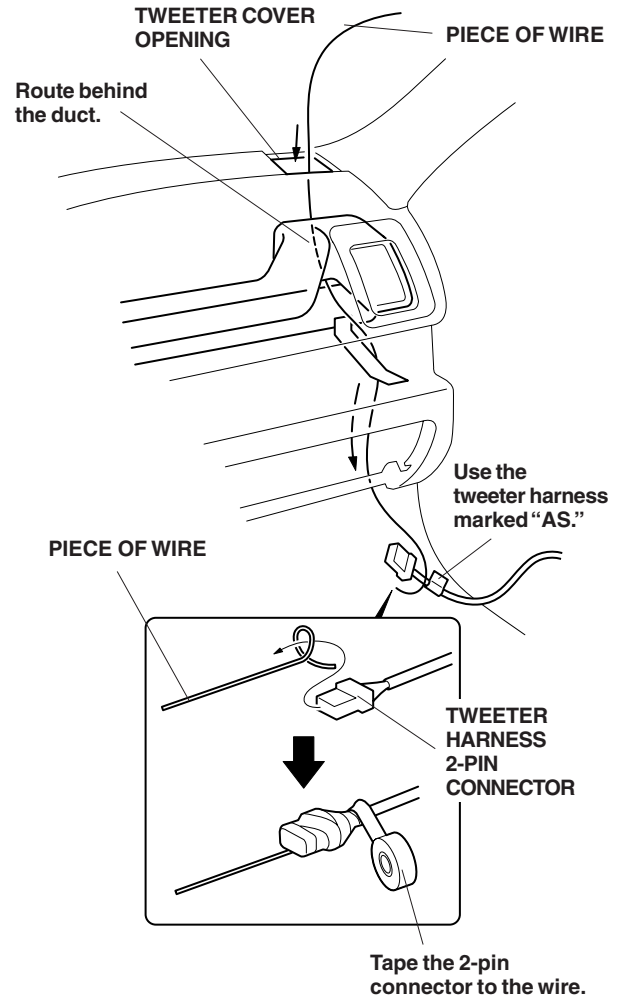

21. Pull the right tweeter 2-pin connector up from the floor to the tweeter cover opening.

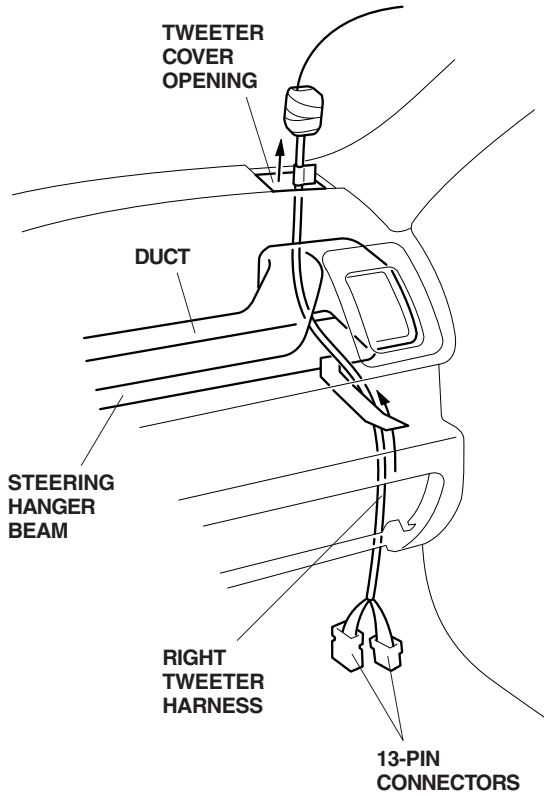

22. Remove the wire from the 2-pin connector. To prevent the tweeter harness from falling, tape it to the dashboard.

23. Plug the two right tweeter harness 13-pin connectors into the vehicle 13-pin connectors you unplugged in step 19.

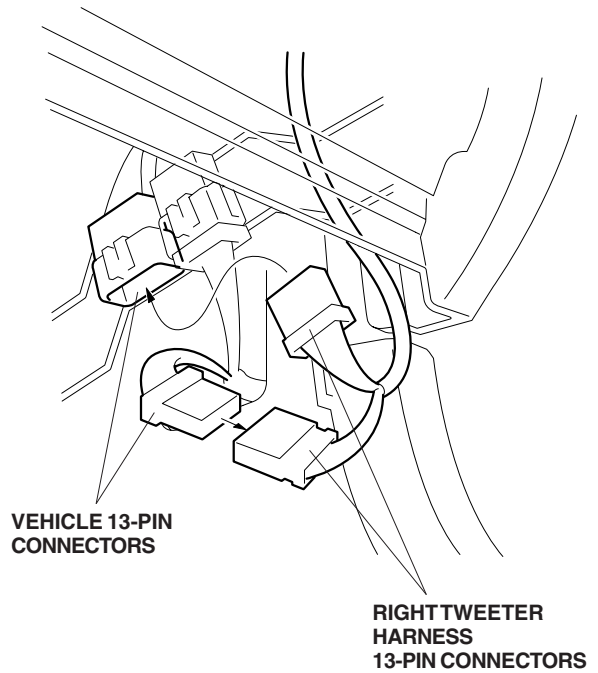

24. Get the other tweeter from the kit. Install the tweeter on the back of the tweeter cover by engaging the three tabs with the square holes in the tweeter cover.

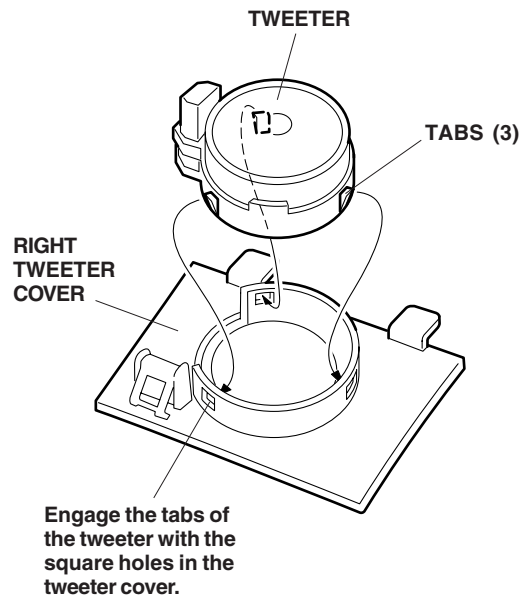

25. Plug the right tweeter harness 2-pin connector into the 2-pin connector of the tweeter, then reinstall the tweeter cover.

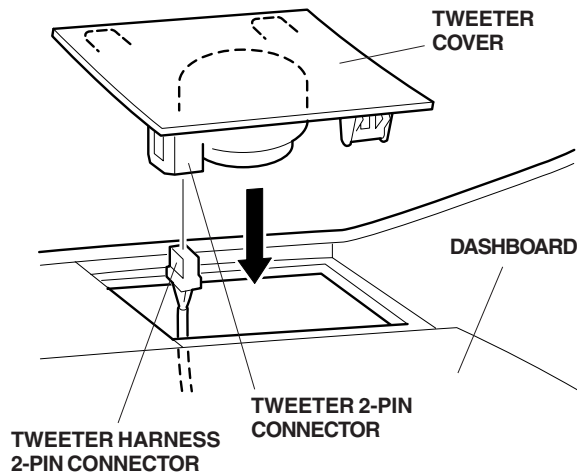

26. Slide the right tweeter harness 13-pin connector into the vehicle connector clip. Make loops in the right tweeter harness, and secure it to the vehicle harness with three wire ties in the area shown.

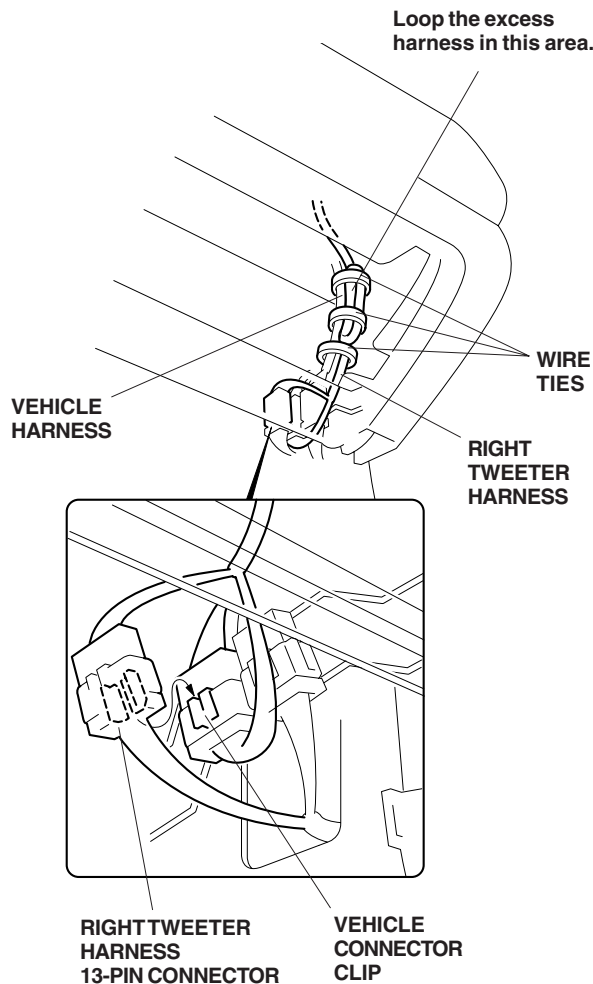

27. Reconnect the negative cable to the battery.
28. Enter the radio anti-theft code, and reset the customer's radio station presets.
29. Reset the clock.
30. Reinstall all removed parts.

**NOTE:** Whenever the battery is disconnected, the driver's window AUTO function is disabled.

31. Start the engine. Push down on the driver's window switch until the window is fully open.
32. Pull up on the driver's window switch to close the window completely, then hold the switch for 2 seconds or more.
33. Test the AUTO window function.
34. Do the ECM/PCM idle learn procedure.

– Make sure all electrical items are turned off.

– Start the engine. Hold the engine speed at 3,000 rpm with no load (in Park or Neutral) until the radiator fan comes on.

– Let the engine idle for about 5 minutes with the throttle fully closed and with all electrical items off.

**NOTE:** If the radiator fan comes on during this step, the time it operates must not be included in the 5 minutes.