



INSTALLATION INSTRUCTIONS

Accessory
AUTOMATIC DAY/NIGHT MIRROR ATTACHMENT KIT

Application
2005 CR-V

Publications No.
All 27160
Issue Date
SEP 2004

PARTS LIST

Automatic Day/Night Mirror Attachment Kit
(sold separately)
P/N 08V03-S9A-101

Upper and lower covers

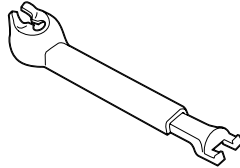

Clip



Day/night mirror harness

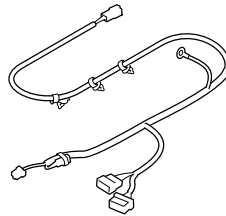

Mirror harness



10 Wire ties

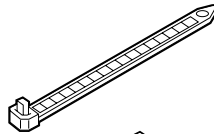

2 EPT sealer

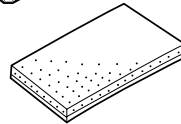

Ground bolt

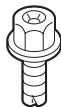

Automatic Day/Night Mirror Kit
(sold separately)
P/N 08V03-S9A-100B

Day/Night mirror

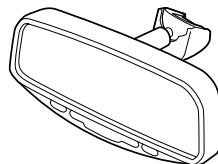

Owner's Manual

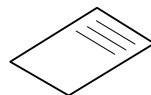

TOOLS AND SUPPLIES REQUIRED

- Phillips screwdriver
- Flat-tip screwdriver
- Small flat-tip screwdriver
- 10 mm Combination wrench
- Ratchet
- 8 mm, 10 mm and 14 mm Sockets
- T20 and T25 Torx bits
- Diagonal cutters
- Torque wrench
- Isopropyl alcohol
- Shop towel
- Piece of steel wire
- Tape measure
- Scissors
- Electrical tape
- Pliers

Illustration of the Day/Night Mirror Installed on the Vehicle

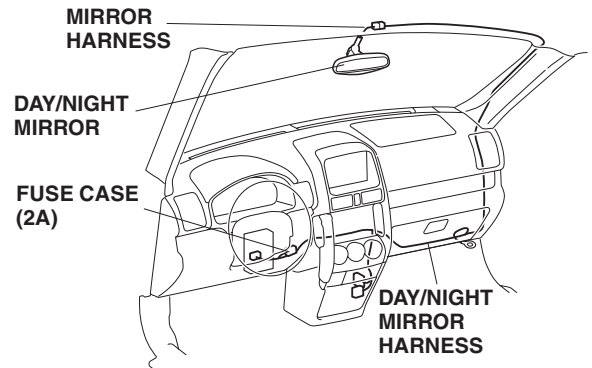

INSTALLATION

Customer Information: The information in this installation instruction is intended for use only by skilled technicians who have the proper tools, equipment, and training to correctly and safely add equipment to your vehicle. These procedures should not be attempted by "do-it-yourselfers."

1. Make sure you have the anti-theft code for the radio, then write down the radio station presets.
2. Disconnect the negative cable from the battery.

3. Remove the lens from the roof console (four retaining tabs).

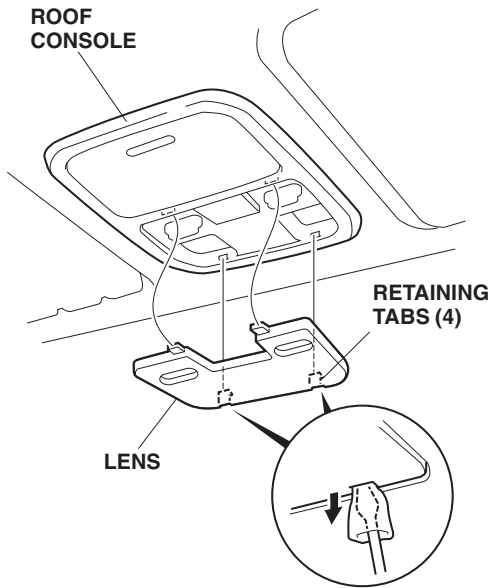

4. Remove the roof console (four screws, and unplug one connector).

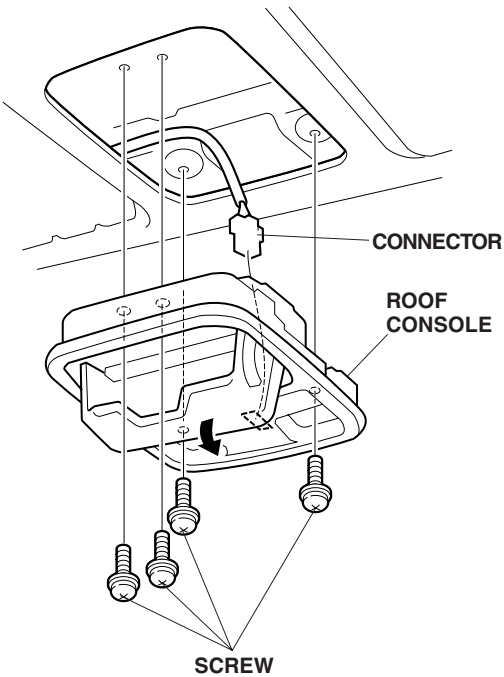

5. Remove the mirror by sliding the mirror up.

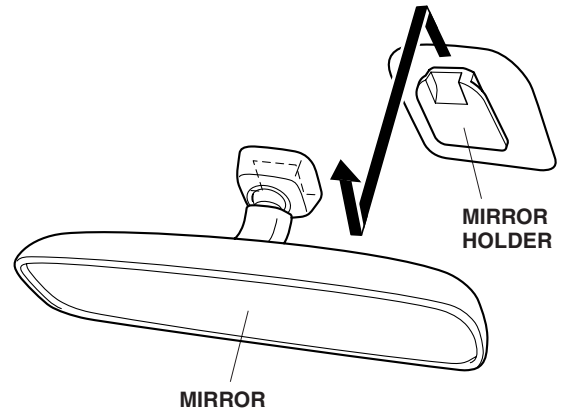

6. Remove the sunvisor holders. Turn the holder 90°, then pull it out.

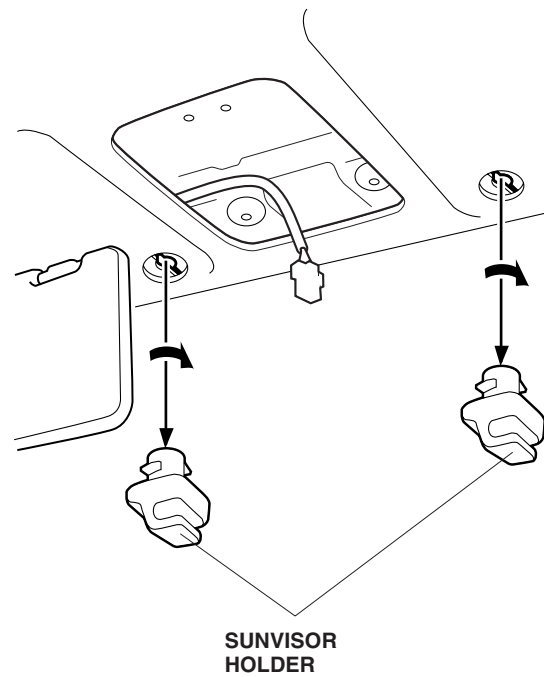

- Remove the cap from the right sunvisor (four retaining tabs).

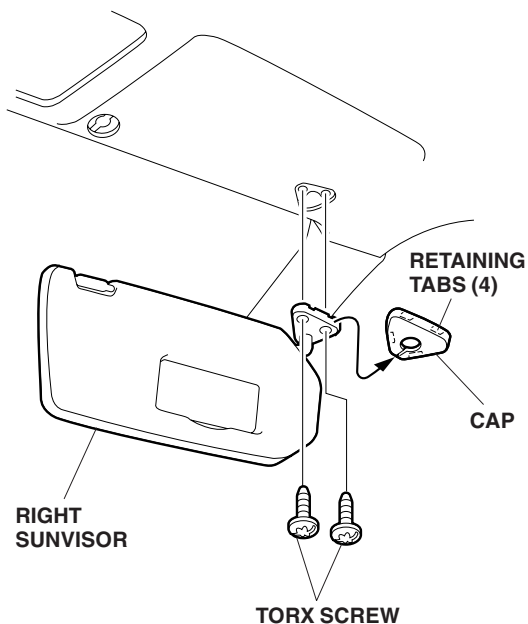

- Remove the right sunvisor (two T25 Torx screws).
- Remove the door opening weatherstrip from the right front pillar in the area shown. Remove the right front pillar trim (2 clips).

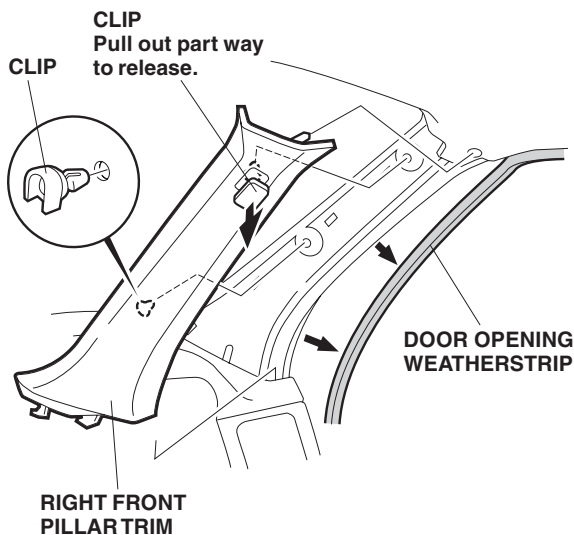

- Remove the passenger's dashboard under cover (release the three clips and two pins.)

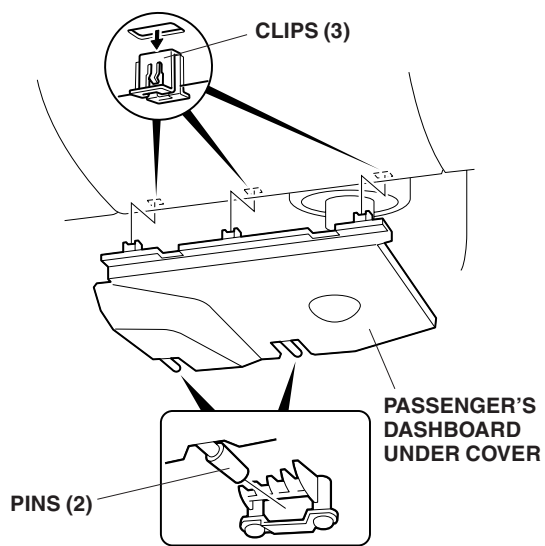

- Open the glove box. Release the right and left stops.

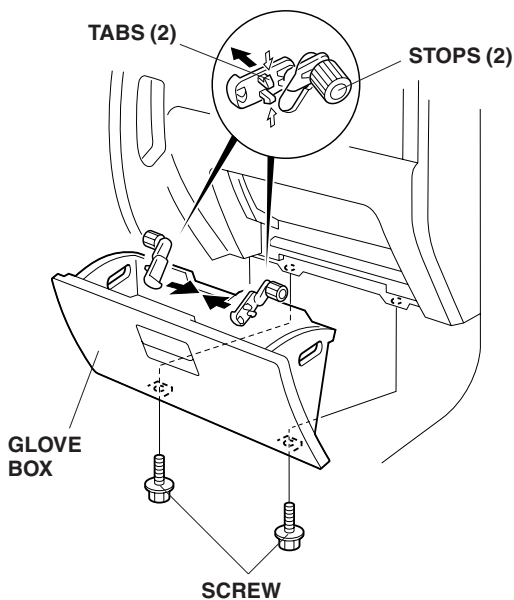

- Remove the two screws from the bottom of the glove box, and remove the glove box.

13. Remove the right kick panel (pull to release the two clips).

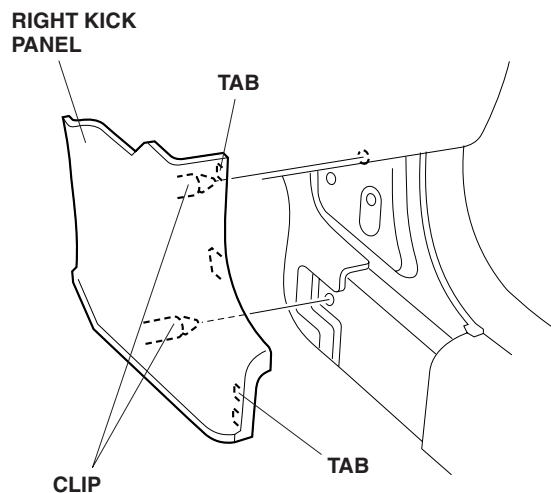

14. Turn the knob clockwise, and remove the driver's dashboard under cover (one clip).

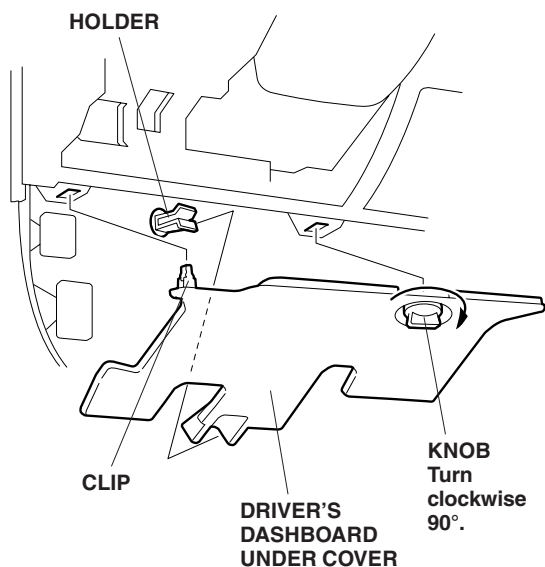

15. Remove the driver's dashboard lower cover:

- Remove the fuse box lid, and open the pocket.
- Remove the two self-tapping screws.
- Gently pull out on the driver's dashboard lower cover to release the eight clips. If equipped, unplug the vehicle connector and remove the lower cover.

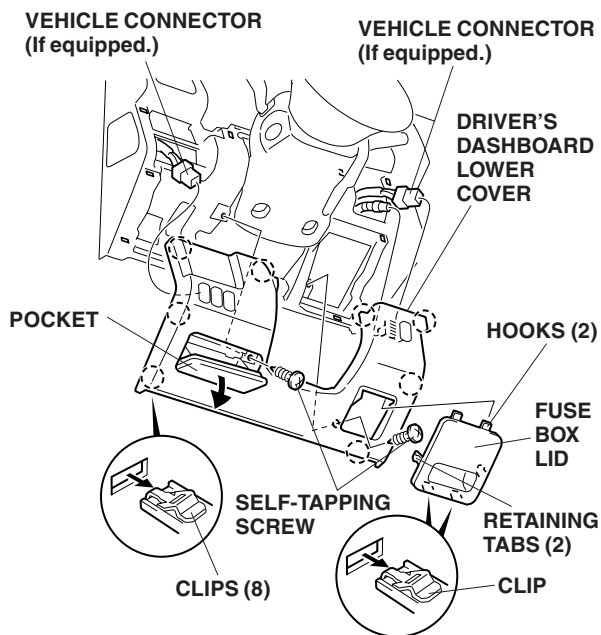

16. Open the dashboard pocket lid. Using a flat-tip screwdriver wrapped with tape, remove the screw cover by releasing the two retaining clips and two retaining tabs. Remove the dashboard pocket (one self-tapping screw, then pull out to release the one clip and three retaining tabs). If equipped, unplug the vehicle connector.

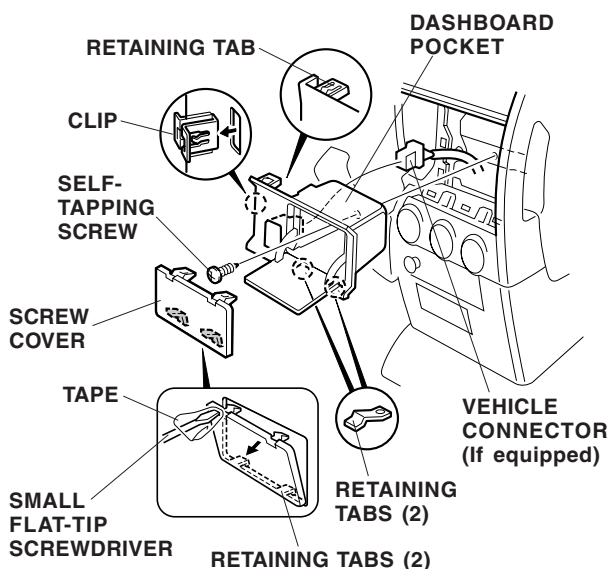

- Remove two self-tapping screws that fasten the heater A/C control panel to the dashboard. Pull the heater A/C control panel out toward you to release the four clips. Unplug the vehicle connector, and remove the heater A/C control panel.

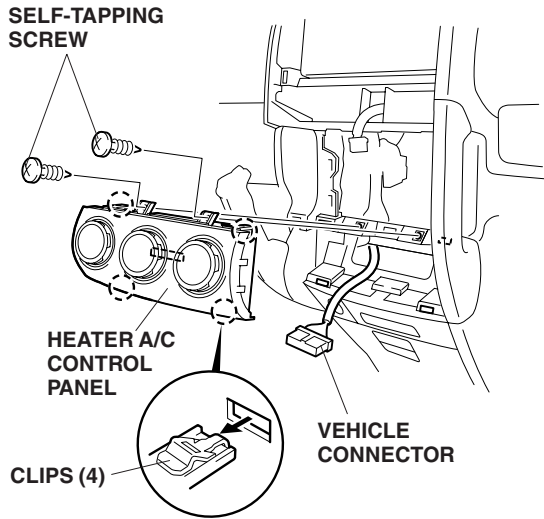

- On A/T vehicles only, remove the two clips and six self-tapping screws, and pull the dashboard center lower cover out toward you to release the six clips. Unplug the vehicle 2-pin connector from the accessory socket, and remove the cover.

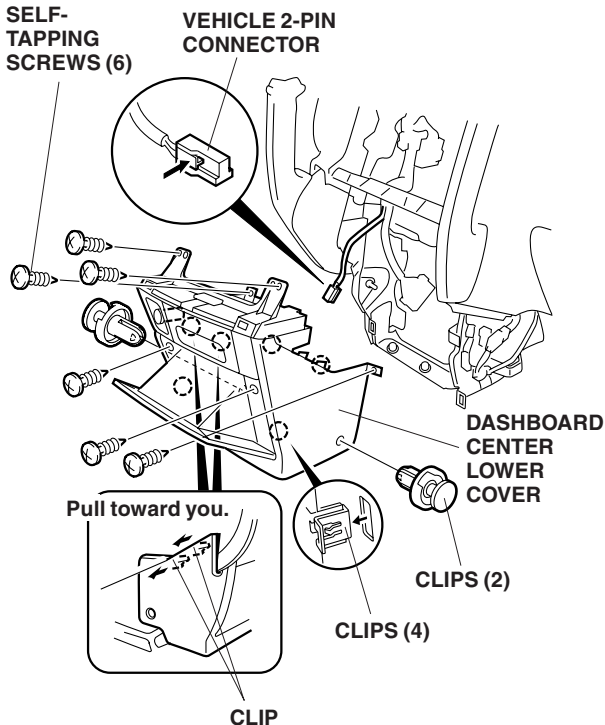

- On M/T vehicles only, remove the four seat track end covers from the driver's seat, then remove the four bolts that secure the seat.

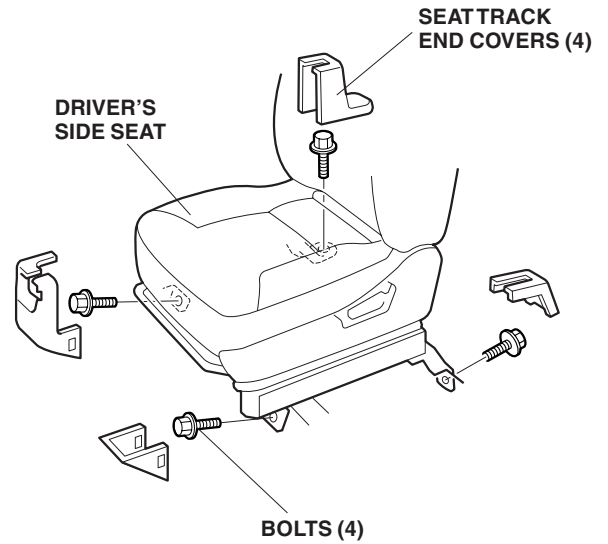

- On M/T vehicles only, pull the shift boot down while holding the plastic clip. Remove the shift knob from the shift lever by turning it counterclockwise.

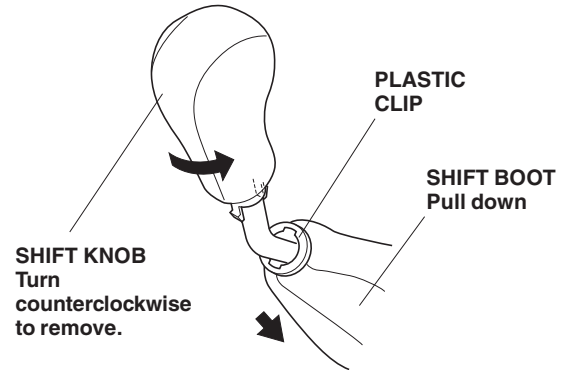

21. On M/T vehicles only, remove the two side covers (four tabs) from the center console.

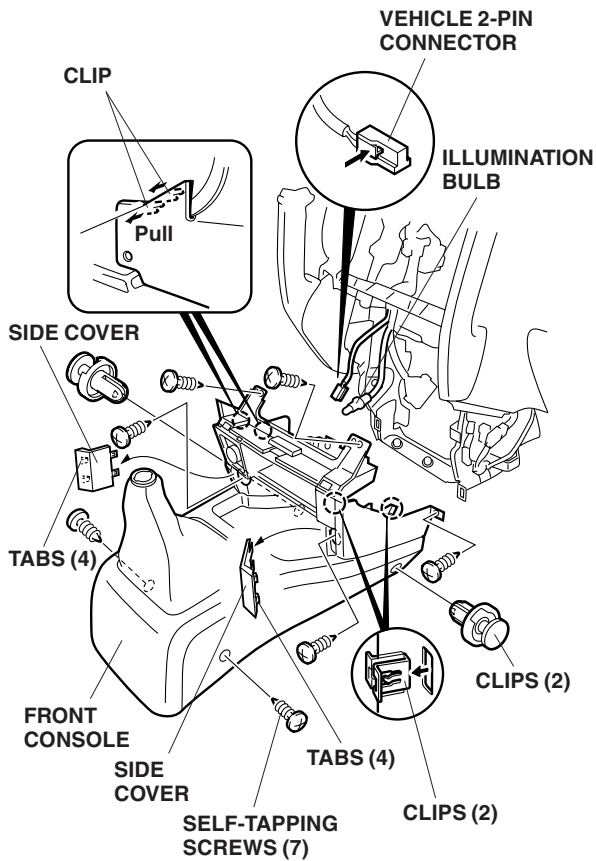

22. On M/T vehicles only, remove the two clips and seven self-tapping screws, and pull the front console out toward you to release four clips. Unplug the vehicle 2-pin connector from the accessory socket, and remove the front console.

23. Slide the day/night mirror stay onto the mirror holder, then tighten the T20 Torx screw installed the day/night mirror.

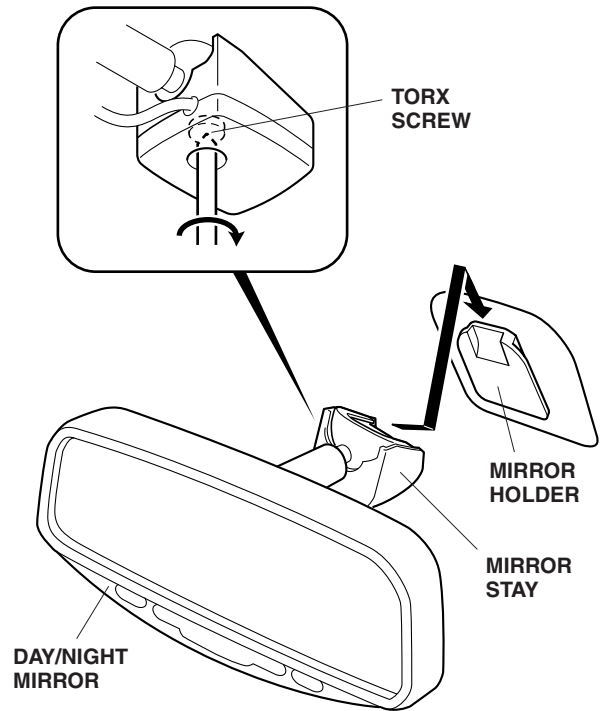

24. Plug the mirror harness 7-pin connector into the rear of the mirror, then route the 4-pin connector up and out through the console opening in the roof lining as shown.

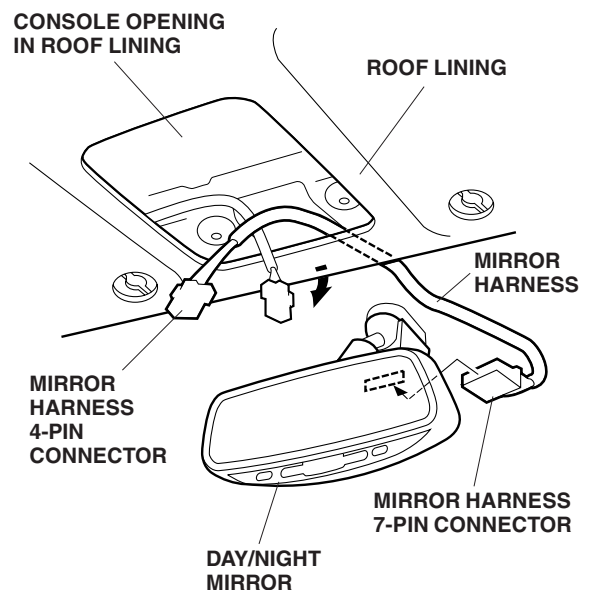

- Route the mirror harness through the grooves of the upper and lower covers. Attach the lower cover to the stay of the mirror.

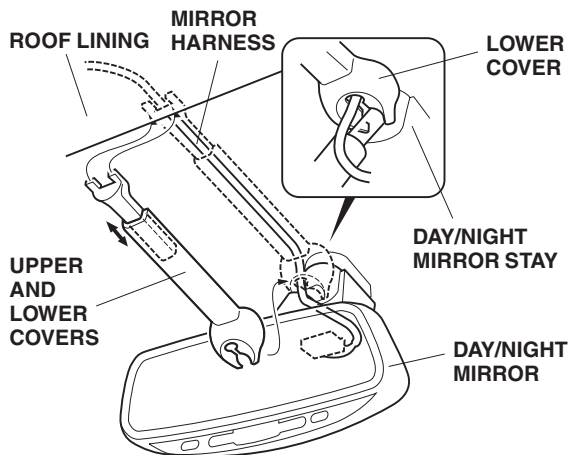

- Slide the upper cover up and under the roof lining as shown.
- Unplug the vehicle connectors (gray) and disengage the clip installing the vehicle 21-pin connector (white) to the right center frame.

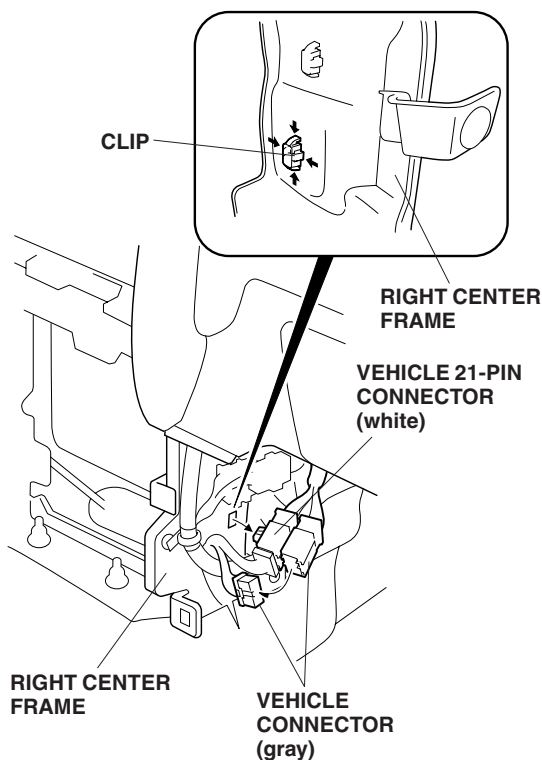

- Unplug the vehicle 21-pin connector (white) and connect the day/night mirror harness 21-pin connectors between the vehicle 21-pin connectors (white).

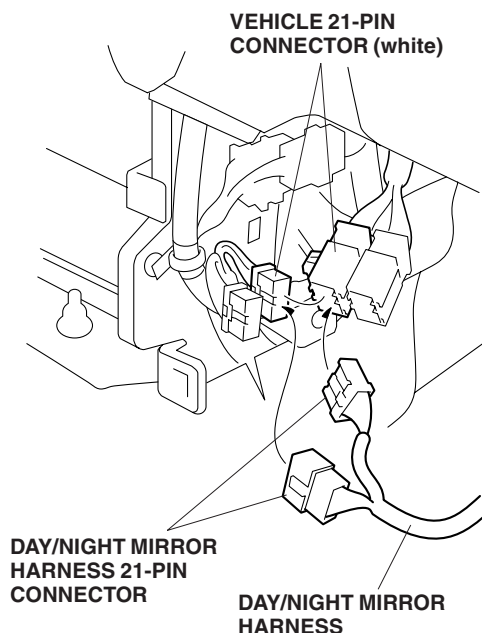

- Remove the connector clip from the vehicle 21-pin connector (white) and install the new clip supplied with the kit onto the vehicle 21-pin connector.

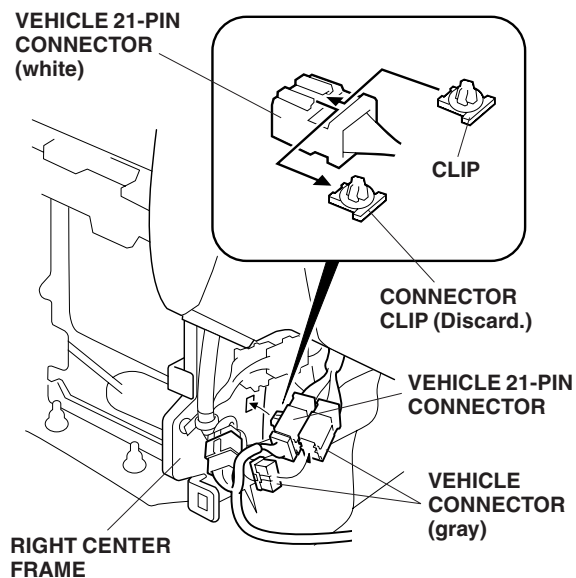

- Reconnect the vehicle connector (gray) and attach the clip you just installed on the vehicle 21-pin connector (white) to the right center frame.

31. Route the day/night mirror harness 4-pin connector with fuse case upwards to the vehicle harness, and then along the vehicle harness to the fuse box through the dashboard pocket opening.

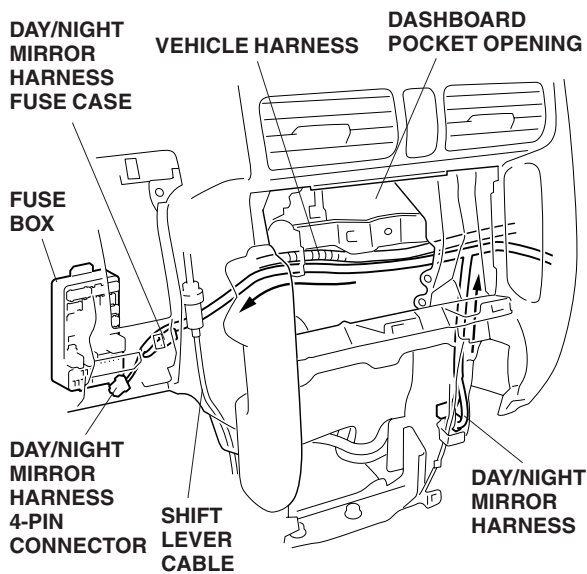

32. Connect the day/night mirror harness 4-pin connector to the accessory terminal of the fuse box.

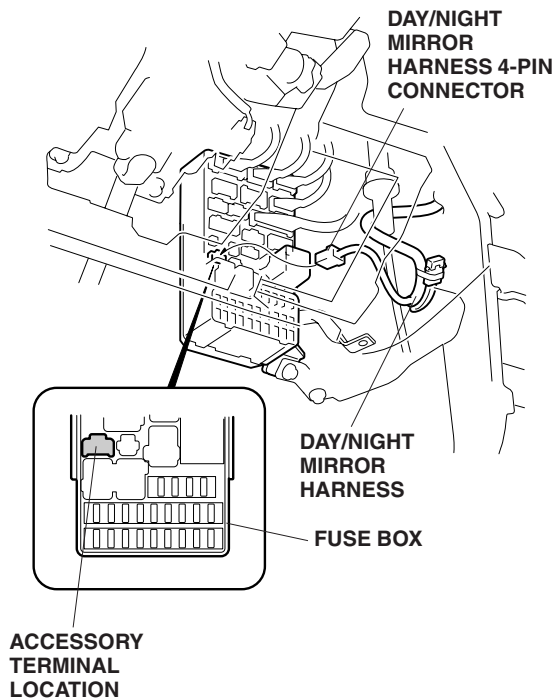

33. Route the day/night mirror harness ground terminal to the right along the vehicle harness at the rear of the glove box frame.

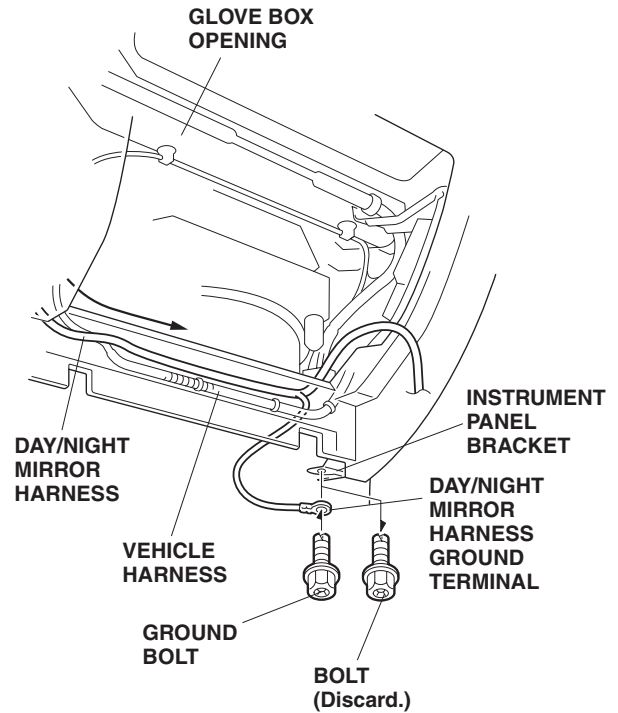

34. Remove and discard the instrument panel bracket bolt, and secure the day/night mirror harness ground terminal to the instrument panel bracket with the new ground bolt supplied.

35. Tape a piece of steel wire to the 4-pin connector end of the day/night mirror harness. Route the harness end up along the instrument panel side bracket, and out through the clearance between the right front pillar and the instrument panel as shown.

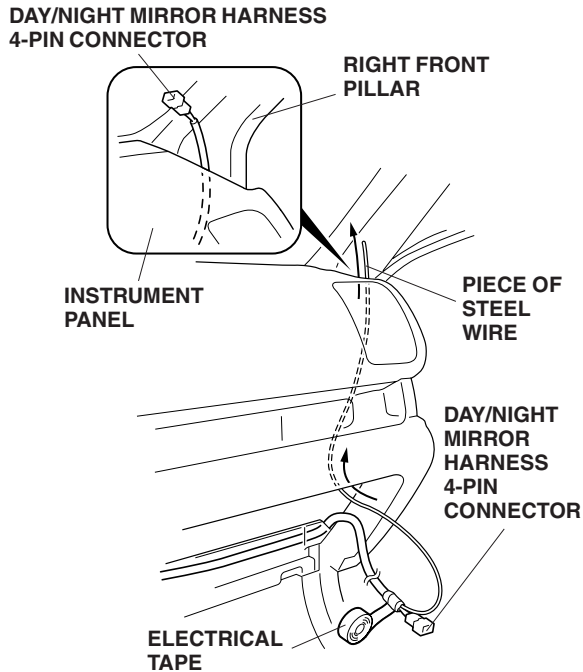

36. Remove the electrical tape and the steel wire from the day/night mirror harness.
37. Continue routing the day/night mirror harness 4-pin connector up along the right front pillar, and out through the roof console opening behind the head liner.

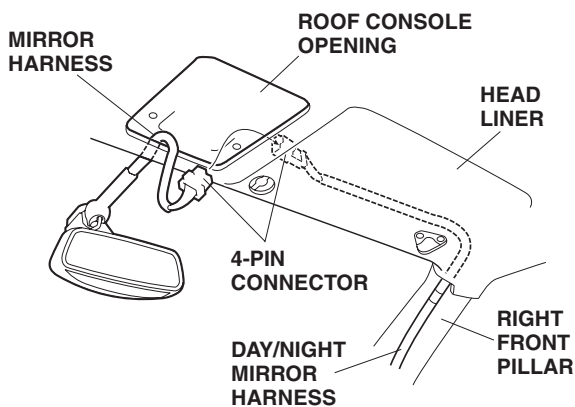

38. Connect the day/night mirror harness 4-pin connector to the mirror harness 4-pin connector.

39. Secure the three clips from the day/night mirror harness into the holes in the right front pillar.

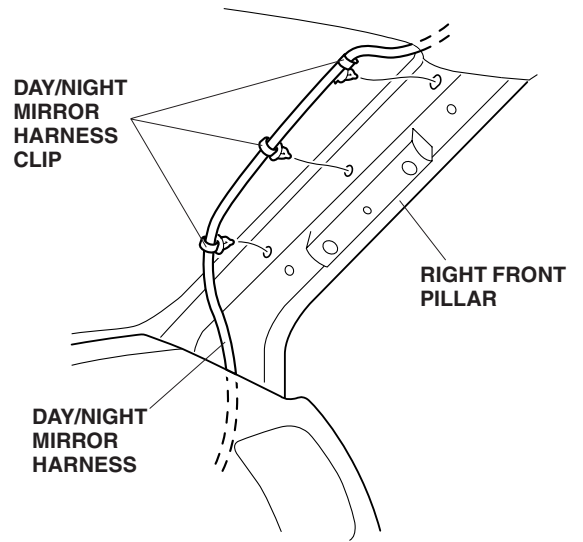

40. Using isopropyl alcohol, clean the areas where the cushion tapes will attach. Using scissors, cut two EPT sealers in half. Secure the day/night mirror harness to the roof panel with three EPT sealers.

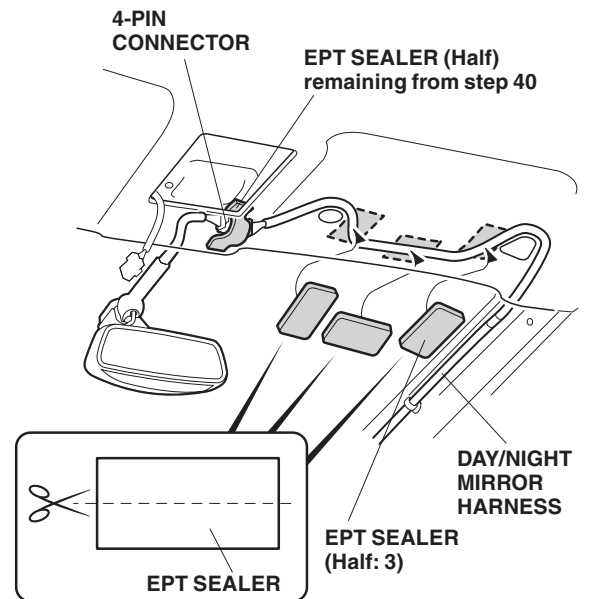

41. Using the remaining half of EPT sealer, secure day/night mirror harness 4-pin connector to the roof panel.

42. Secure the day/night mirror harness to the vehicle harness with four wire ties.

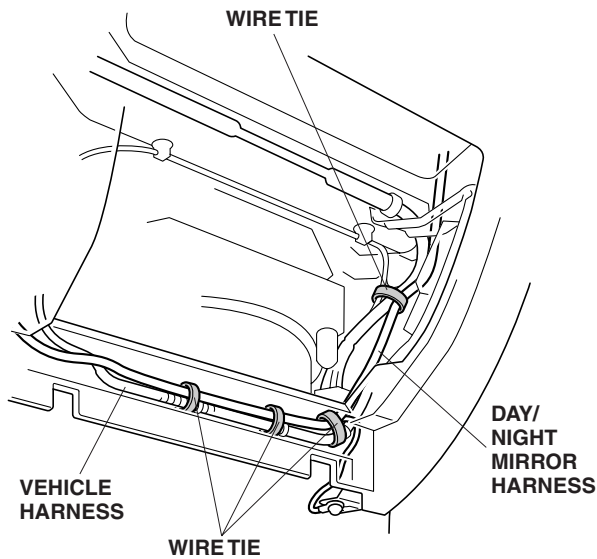

43. Secure the day/night mirror harness to the vehicle harness with three wire ties.

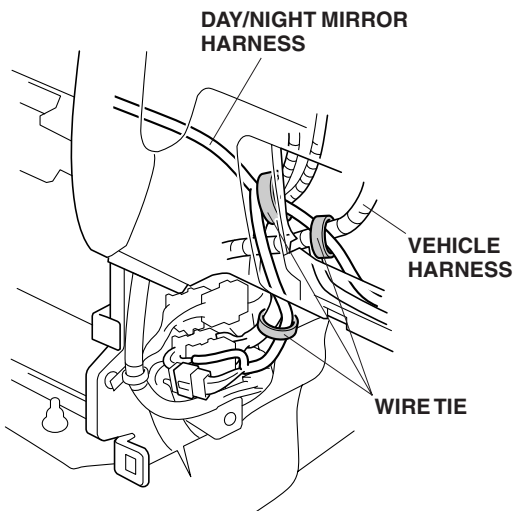

44. Under the dashboard, secure the day/night mirror harness to the vehicle harness with three wire ties.

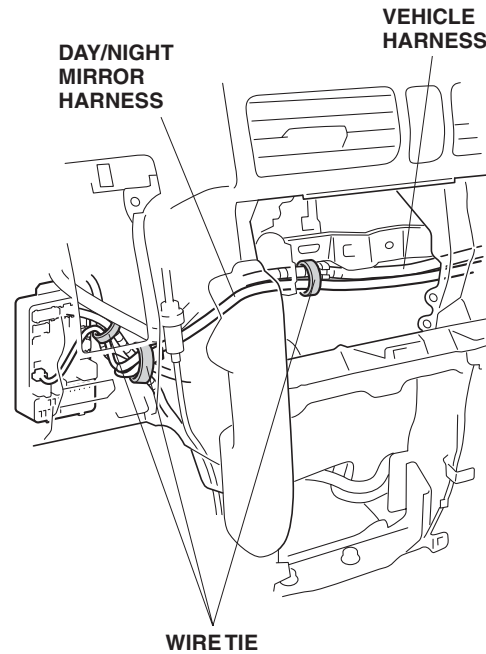

45. Check that all wire harnesses are routed properly and all connectors are plugged in.
46. Reinstall the driver's side seat, torque the driver's seat bolts to 32 to 38 N·m (24 to 28 lb·ft)
47. Reinstall all removed parts. Check that all clips and other fasteners are installed securely.
48. Reconnect the negative cable to the battery.
49. Set the clock, and reset the radio station presets.
50. Check the operation of the automatic day/night mirror according to the Owner's Manual supplied.

NOTE: Whenever the battery is disconnected, the driver's AUTO function is disabled.

51. Start the engine. Push down on the driver's window switch until the window is fully open.
52. Pull up on the driver's window switch fully to close the window completely, then hold the switch for 2 seconds.
53. Test the driver's window AUTO function.