



INSTALLATION INSTRUCTIONS

Accessory

MOONROOF VISOR
08R01-SDA-100

Application

2003 ACCORD
4-DOOR

Publications No.

All 24059

Issue Date

AUG 2002

Keep this information in the glove box for future reference.

PARTS LIST

Moonroof visor

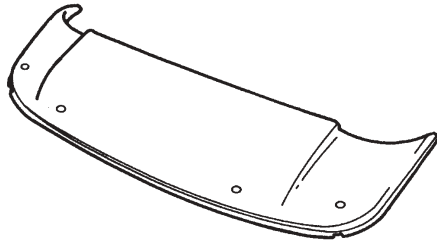

2 Front brackets A
(long)

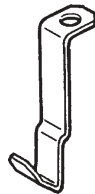

2 Side brackets B
(short)



4 Screws



4 Nuts



4 Protective tapes



TOOLS AND SUPPLIES REQUIRED

Phillips screwdriver

10 mm Combination wrench

Felt-tip pen

Tape measure

Isopropyl alcohol

Shop towel

INSTALLATION

1. Clean and wax the roof area to be covered with a high-quality paste wax.
2. Open the moonroof.
3. Measure the distance between points A and B, and divide that measurement in half to find the center of the moonroof opening (C). Mark the roof at the center (C) with a felt-tip pen.

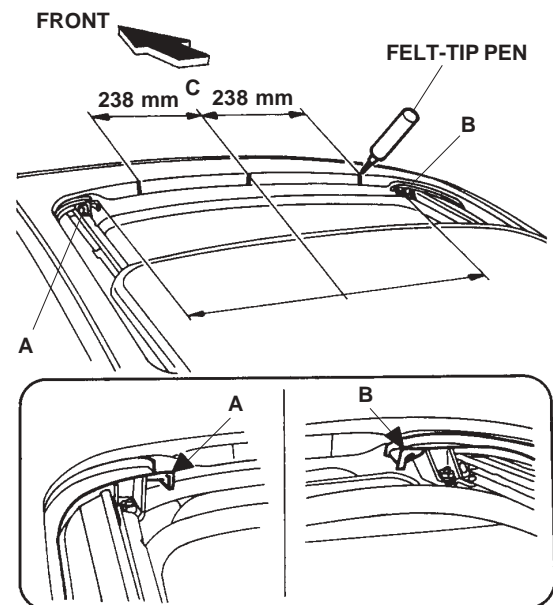

4. From the center point (C), measure 238 mm to each side, and mark the roof using a felt-tip pen.

5. Locate the panel joint on the right side of the moonroof opening. Measure 48 mm to the front of the car, and mark the measurement on the roof. Repeat on the other side of the moonroof opening.

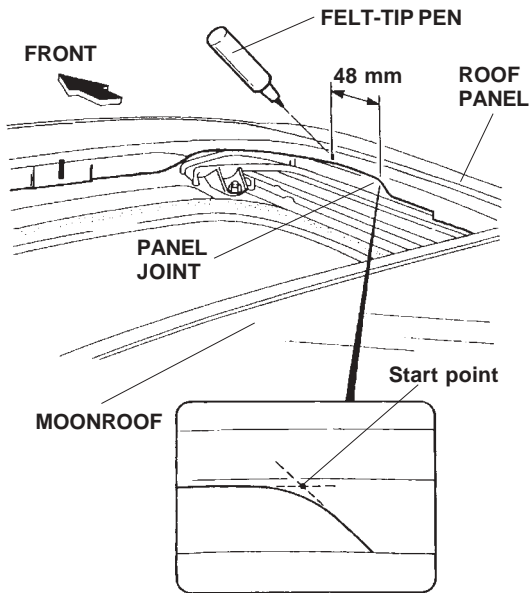

6. Using isopropyl alcohol on a shop towel, clean the roof at each of the four marks you've made.
7. Remove the adhesive backing from the four protective tapes, and attach one to the roof at each of the marks you made. Wrap 6 mm of the protective tape around the lip of the moonroof opening.

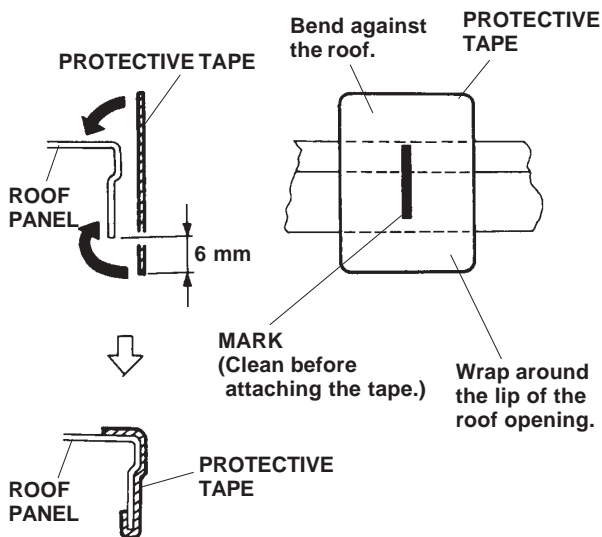

8. Place the two front brackets A into position by sliding them along the lip of the roof opening. Set the moonroof visor on the vehicle's roof, in front of the moonroof opening, and adjust its position so the holes in the visor are aligned with the protective tapes.

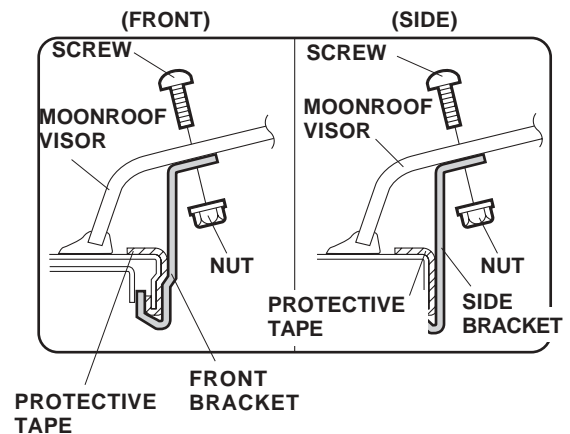
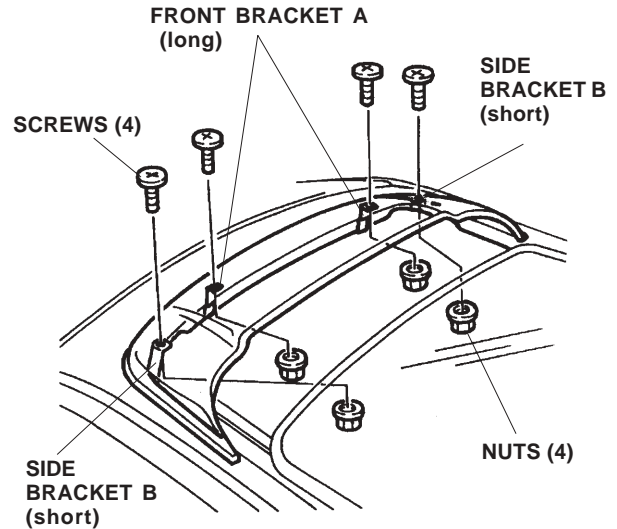

9. While holding the visor in place, install the four screws, four nuts, and four brackets A and B with the end of each bracket hooked to the lip of the moonroof opening. Do not tighten the screws yet.

- Position the moonroof visor with equal spacing on all sides. Check that the rubber seal is not twisted or rolled under the visor.

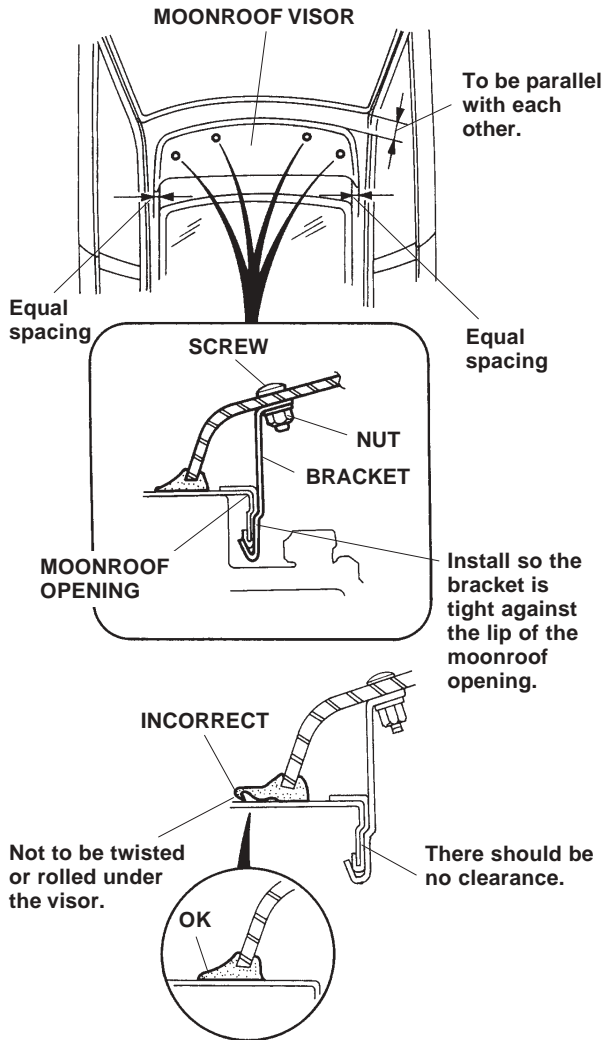

- Tighten the nuts and screws, alternating between sides. To prevent damage to the resin nuts, do not overtighten the screws.

CARE OF YOUR MOONROOF VISOR

- To avoid damaging the surface, never use ammonia-based cleaners or solvents to clean your moonroof visor.
- Clean with a solution of mild dishwashing soap and water using a soft cloth or chamois.
- To remove fine scratches and restore the original luster, use Meguiar's Mirror Glaze plastic cleaner and polish or an equivalent high-quality plastic cleaner.