



INSTALLATION INSTRUCTIONS

Accessory

**DOOR VISOR
P/N 08R04-SDN-100**

Application

**2003 ACCORD
2-DOOR**

Publications No.

All 24071

Issue Date

SEP 2002

PARTS LIST

Left Door visor

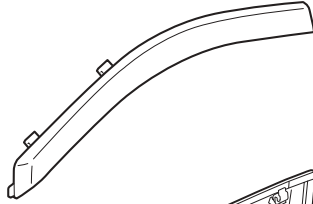

Right Door visor

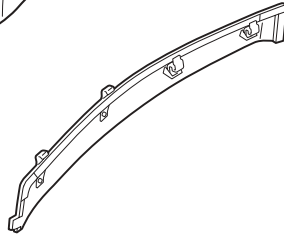

Primer

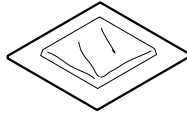

2 EPT sealers

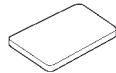

SUPPLIES REQUIRED

Isopropyl alcohol

Shop towel

Masking tape

INSTALLATION

NOTE:

- These instructions show the left door visor being installed. The same procedure applies to installing the right door visor.
- Be careful not to damage the paint finish and glass run channels when installing the door visors.
- Handle the door visors with care. They are not designed to absorb shock or impact.
- This door visor kit should only be installed if the ambient air temperature is 60°F (15°C) or above.
- To allow the adhesive to “cure”, do not wash the car for 24 hours.
- Read the label on the primer before using the primer.

1. Lower the door glass completely. Remove the door glass run channel from the door sash in the area shown. Do not remove the glass run channel from the door mirror base and the rear end of the door.

**DOOR MIRROR BASE
(Do not remove the
door glass run
channel here.)**

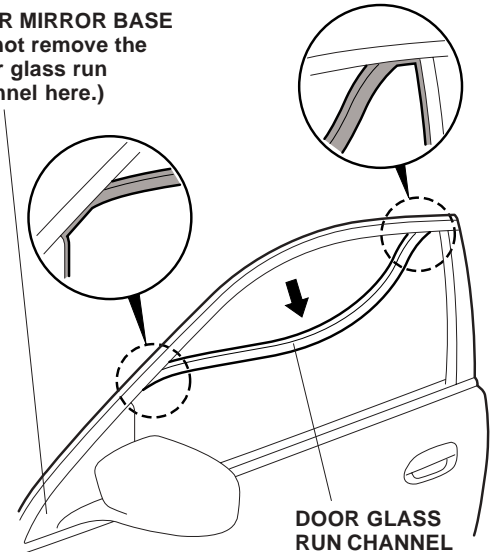

2. Using isopropyl alcohol on a shop towel, clean the area where the EPT sealer will attach.
3. Remove the door weatherstrip in the area shown, and remove the self-tapping screw that fastens the door sash trim. Lift the trim up away from the door sash.

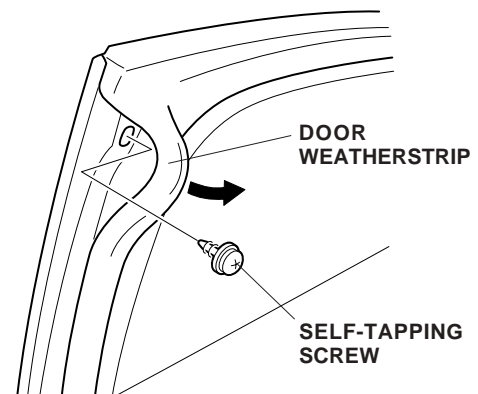

- Remove the adhesive backing from the EPT sealer, and align the bottom edge of the EPT sealer with the door sash. Attach the EPT sealer with 2.5 mm of the EPT sealer placed under the door sash trim.

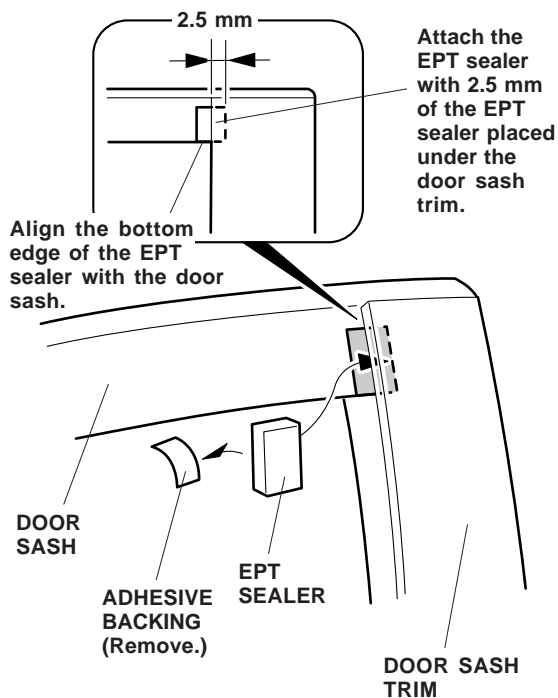

- Reinstall the self-tapping screw and door weatherstrip.
- Apply the masking tape to the outer door sash 5 mm from the edge in the area shown.

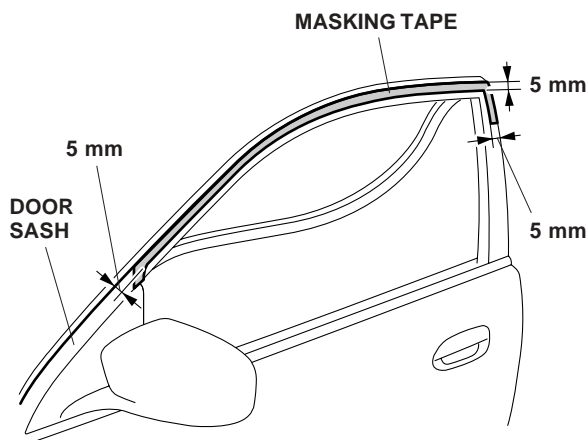

- Using isopropyl alcohol on a shop towel, clean the door sash inside the masking tape. Also clean the door sash trim inside the masking tape with isopropyl alcohol by rubbing the surface with force at least 6 times both ways.

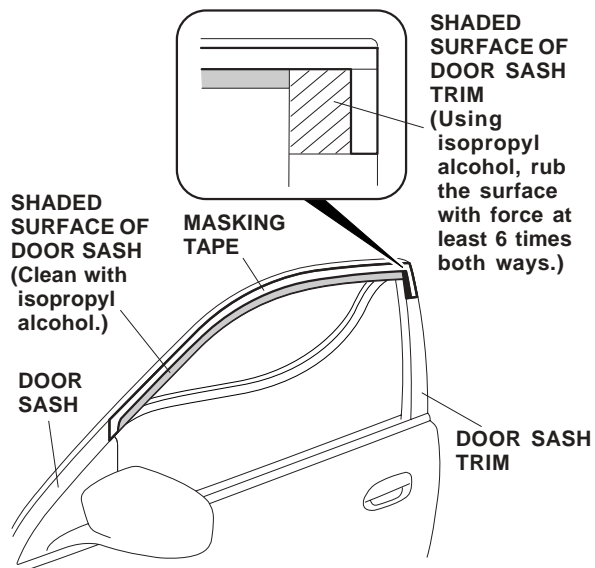

- While wearing gloves, apply the primer to the door sash below the masking tape. Do not apply the primer to the door sash trim. Wipe up excess primer at once. Allow the primer to dry for at least 3 minutes, then remove the masking tape.

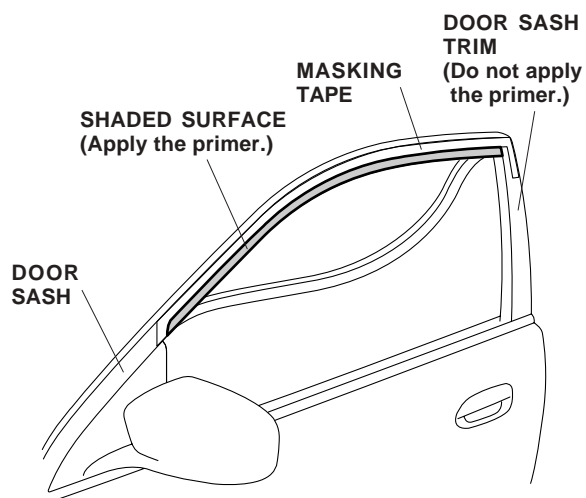

- Attach the masking tape to the door visor in the area shown.

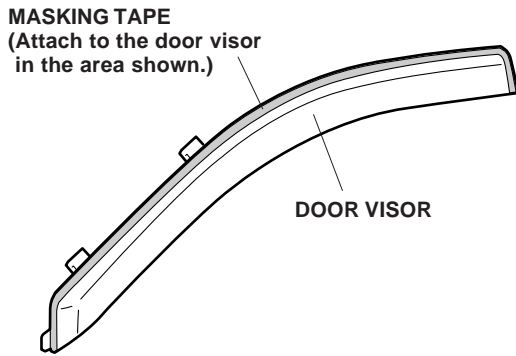

- Remove the two small pieces of adhesive backing from the front of the door visor.

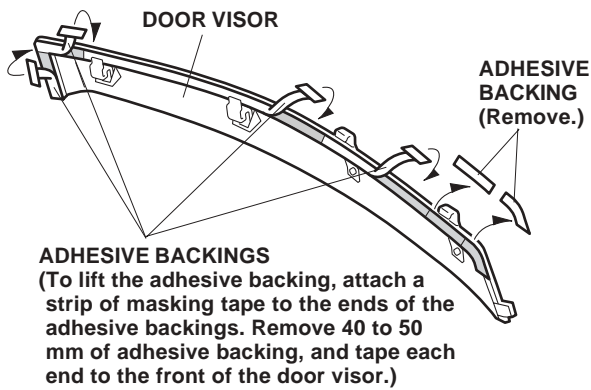

- Attach a strip of the masking tape to the ends of the remaining adhesive backings, and remove 40 to 50 mm from the end. Fold back the ends, and tape the ends to the front of the door visor. Note the direction of the adhesive backings.

- Insert the front tab under the door mirror base. Attach the two front brackets of the door visor to the door sash, and push the two rear brackets on the door sash.

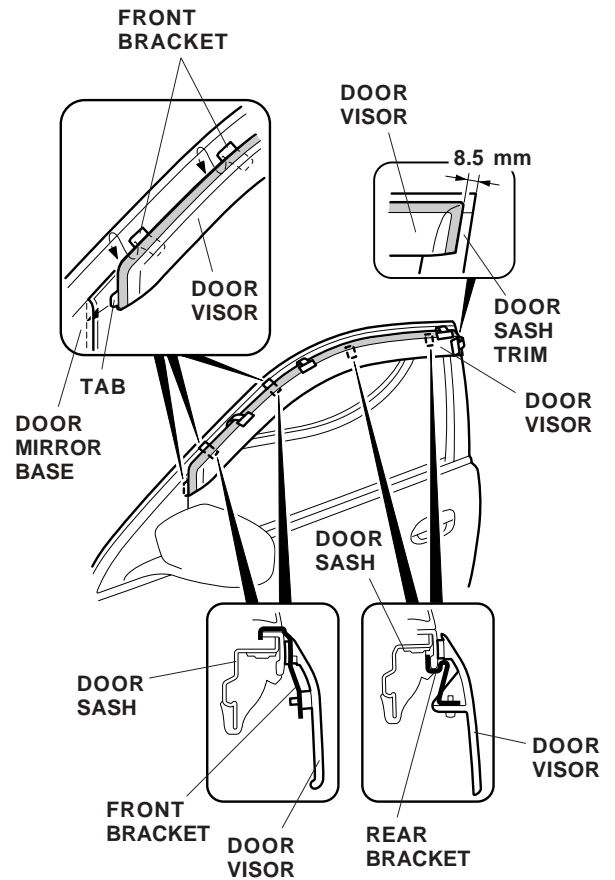

- Adjust the location of the door visor so that the clearance between the door visor and door sash trim is 8.5 mm at the rear of the door. There should be no clearance between the front tab and the door visor.

14. While holding light pressure on the door visor, carefully remove the adhesive backings in the directions shown. Using the palm of your hand, hold the door visor firmly against the door for 30 seconds.

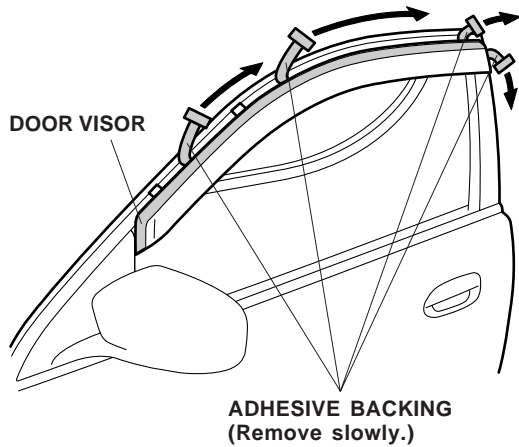

15. Remove the masking tape from the door visor.
16. Reinstall the door glass run channel.

NOTE: Make sure the run channel is seated properly.

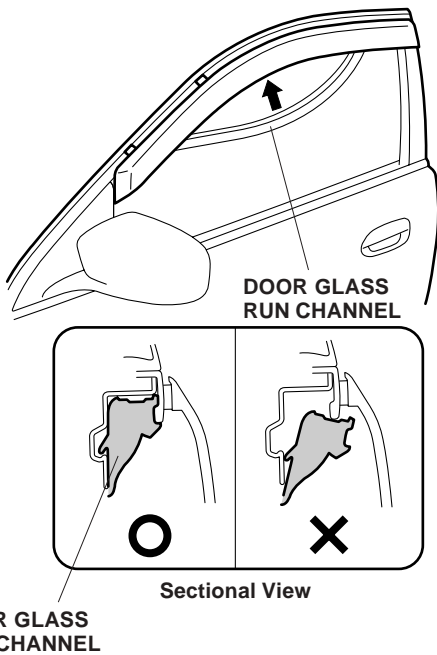

17. Repeat steps 1 thru 16 to install the right side door visor.
18. Raise and lower all the windows several times to seat the glass run channels.

USE AND CARE

- To clean the door visor, wipe it with a soft cloth dampened with clean water.
- To remove dust and dirt, clean with a solution of liquid dishwashing soap and water using a soft cloth or chamois. Never use organic solvents such as thinner, benzene, alcohol, etc., or cleaners containing abrasive compounds.