



# INSTALLATION INSTRUCTIONS

Accessory	Application	Publications No.
17" ALUMINUM WHEEL	2006 RIDGELINE	All 28582
		Issue Date
		FEB 2005

## PARTS LIST

Aluminum wheel for TPMS  
(The illustration may differ from the actual wheel.)

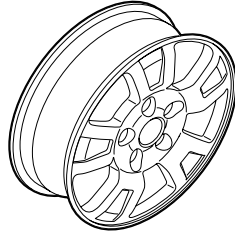

5 Wheel nuts



Valve stem assembly



Wheel center cap  
(The illustration may differ from the actual center cap.)



Center cap emblem



2 Push nuts



Wheel cleaning information  
(Put this information in the glove box.)

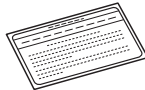

Wheel nut information  
(Put this information in the glove box.)



## TOOLS AND SUPPLIES REQUIRED

Ratchet

Isopropyl alcohol

22 mm Socket

Torque Wrench

1/4" Drive adapter

Shop towel

11 mm Deep socket

Torque Screwdriver

Available through the Honda Tool and Equipment Program at 888 424-6857:

Torque screwdriver Model No.: CDI401SM

## INSTALLATION

**Customer Information:** The information in this installation instruction is intended for use only by skilled technicians who have the proper tools, equipment, and training to correctly and safely add equipment to your vehicle. These procedures should not be attempted by "do-it-yourselfers."

### NOTE:

- This aluminum wheel is designed for use on vehicles equipped with a Tire Pressure Monitoring System (TPMS).
- This accessory wheel is equipped with the TPMS sensor. Refer to the service manual for the tire replacement procedure.
- The illustration of the aluminum wheel shown here is for reference purposes only.
- Install the correct size tire.
- Use a tire changer to remove and install the tires. Using a tire lever to remove and install the tires could damage the tire, the wheel, and the TPMS valve and sensor.
- The wheel nut torque is 95 lb-ft (127 N-m)
- The center cap emblem and tire pressure caution label should be installed only if the ambient air temperature is 60°F (15°C) or above.
- The ignition switch must remain off while changing the wheels, otherwise; the system will set a TPMS code.
- To avoid performing a memorization check, keep track of each TPMS unit location, and reuse the sensor at the same location

## Installing the TPMS Sensor

1. Remove and discard the valve nut, then remove the tire pressure sensor with valve stem assembly from the wheel.

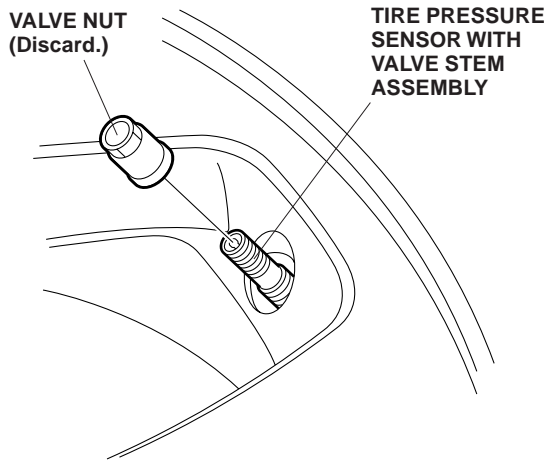

2. Remove and discard the valve stem and the screw from the tire pressure sensor. If the valve stem grommet remained attached to the wheel, remove and discard the grommet before installing the new valve stem.

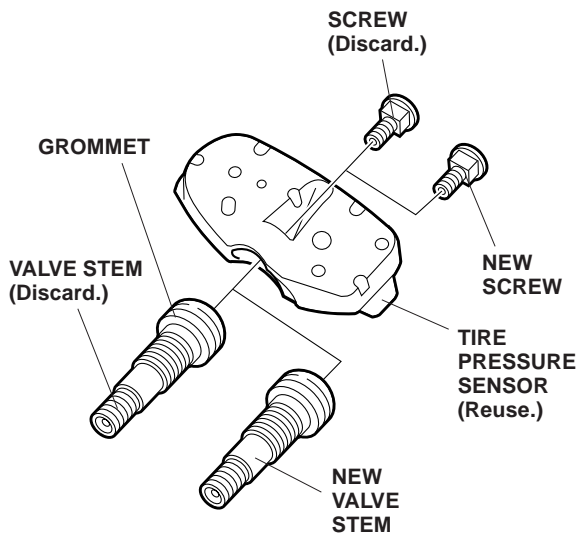

3. Install the new valve stem and screw onto the tire pressure sensor, and hand tighten.

4. Before installing the tire pressure sensor, clean the wheel mating surface and the valve stem hole of the aluminum wheel.

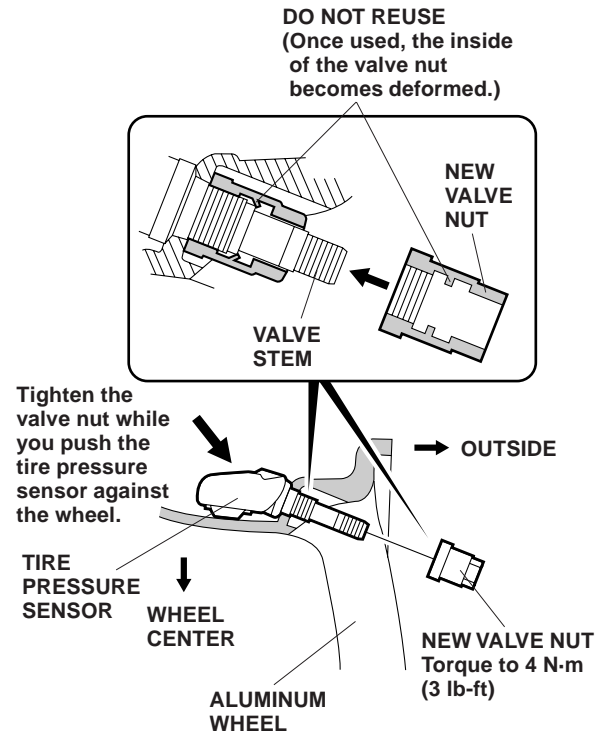

5. Install the tire pressure sensor onto the aluminum wheel, and loosely install the valve nut. Make sure the pressure sensor is resting on the wheel.
6. While holding the tire pressure sensor toward the wheel, tighten the valve nut. You may hear a snap or pop as you tighten the nut. This is normal, do not loosen. Torque the valve nut to 4 N-m (3 lb-ft.)

### NOTE:

- Never reuse any valve nut that had been tightened, even one time. Once used, the inside of the valve nut becomes deformed.
- Never use pneumatic tools to tighten the valve nut.
- Tightening the nut above the specified torque will damage the nut.
- Make sure that there is no space between the sensor and the wheel.

7. Reinstall the tires according to the instructions in section 18 of the service manual.

### Replacing the Wheel Nuts

8. Install the wheels using the wheel nuts supplied. Never install an aluminum wheel using the wheel nuts from a steel wheel. Torque the wheel nuts to 95 lb-ft (127 N-m)

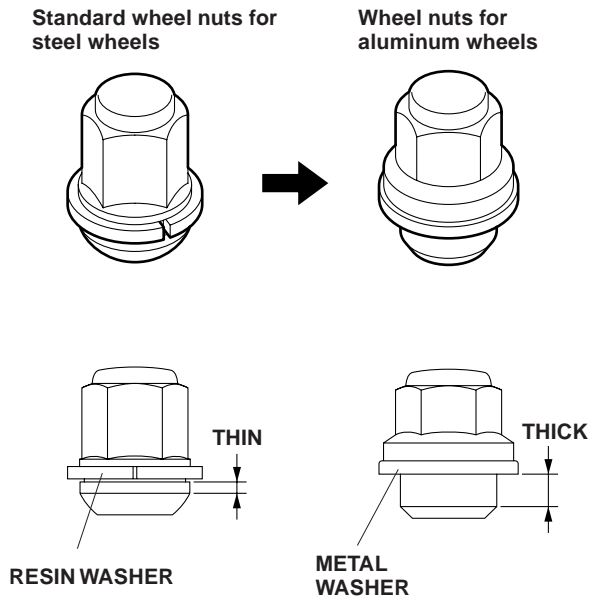

9. If necessary, memorize the tire pressure sensors as described in section 18 of the service manual.
10. Place the wheel cleaning and wheel nut information in the glove box with the vehicle owner's manual.

### Installing the Center Cap Emblems

11. Using isopropyl alcohol on a shop towel, clean the area where the center cap emblem will attach.

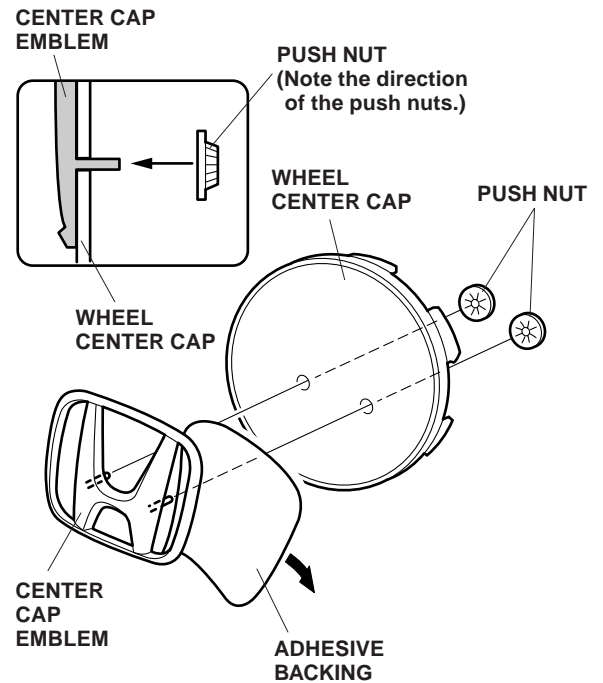

12. Remove the adhesive backing from the center cap emblem.
13. Attach the center cap emblem to the wheel center cap by aligning its pins with the holes in the wheel center cap. After attaching, hold the emblem firmly against the wheel center cap with the palm of your hand for 30 seconds.
14. Slide the push nuts onto the pins. Note the direction of the push nuts.
15. Repeat steps 11 thru 14 to install the three remaining center cap emblems.