



# INSTALLATION INSTRUCTIONS

Accessory

**CIGARETTE LIGHTER WITH ASHTRAY  
(EX, GX, LX, VP)**

Application

**2005 CIVIC  
2 AND 4-DOOR**

Publications No.

**All 27859**

Issue Date

**AUG 2004**

The Cigarette Lighter with Ashtray *cannot be installed* if the vehicle is equipped with either Fog Lights or a Front Under Spoiler.

## PARTS LIST

Center lower cover

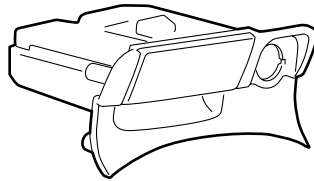

Lighter harness

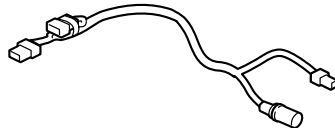

2 Wire ties

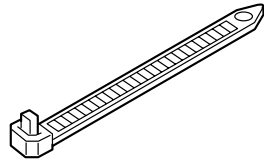

Self-tapping screw



Screw grommet



Knob

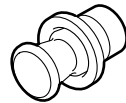

Socket

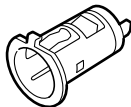

Ring (for 2-door model)



Ring (for 4-door model)



## TOOLS REQUIRED

- Flat-tip screwdriver
- Diagonal cutters
- Phillips screwdriver

## INSTALLATION

**Customer Information:** The information in this installation instruction is intended for use only by skilled technicians who have the proper tools, equipment, and training to correctly and safely add equipment to your vehicle. These procedures should not be attempted by "do-it-yourselfers."

1. Make sure you have the anti-theft code for the radio, then write down the customer's radio station presets.
2. Disconnect the negative cable from the battery.
3. Remove the driver's dashboard lower cover. Turn the two knobs counterclockwise, and release the four retaining tabs.

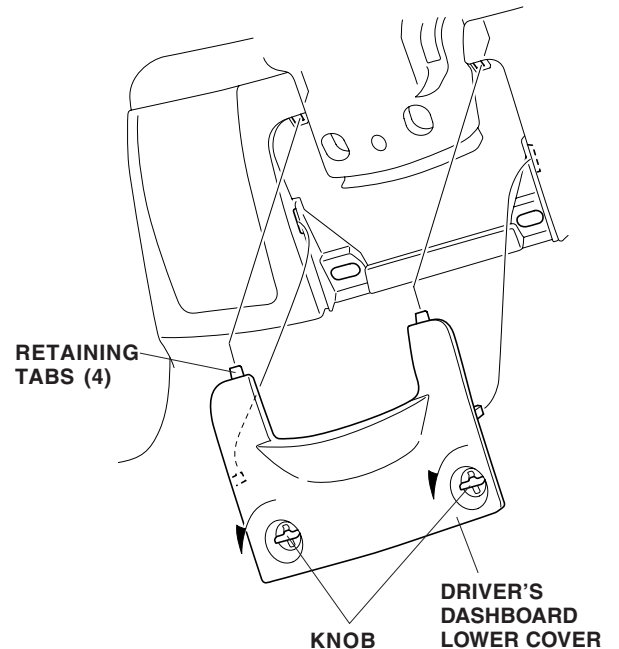

- Remove the driver's dashboard under cover. Turn the knob counterclockwise, and release the two clips and one retaining tab.

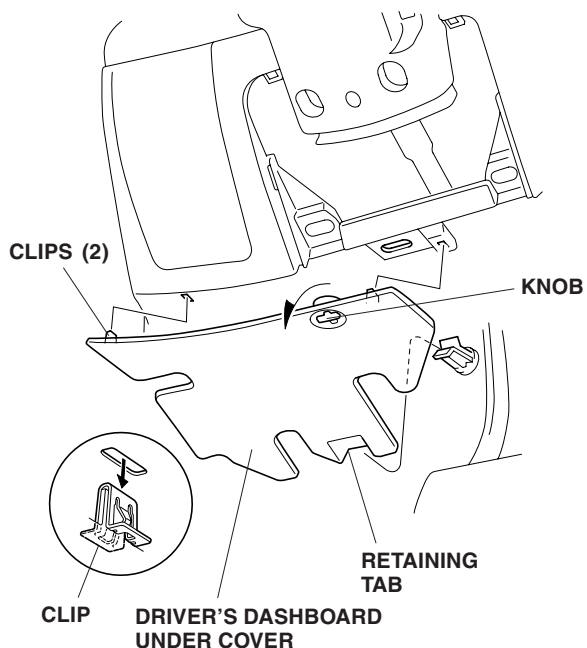

- Pry up on the four retaining tabs and remove the escutcheon.

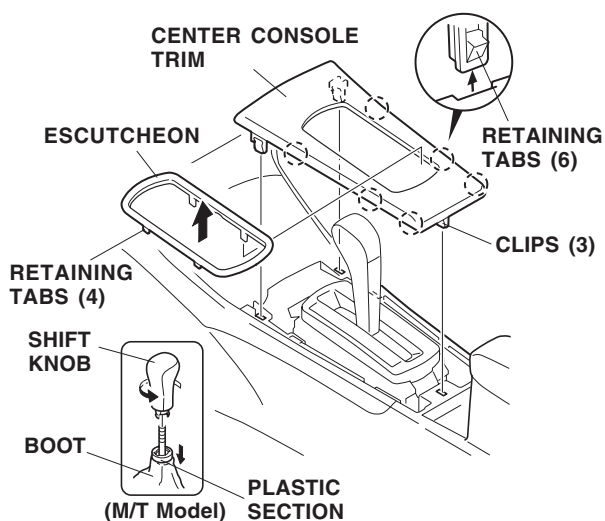

- Pry up on the three clips and six retaining tabs and remove the center console trim. On the M/T model, remove the shift knob from the lever by pulling the plastic section above the boot down firmly with one hand, while you turn the knob counterclockwise with the other hand.

- Remove the center lower trim:
  - With the parking brake applied, place the gear shift lever in the Neutral position.
  - Remove the two self-tapping screws that fasten the lower trim.
  - Gently pry out on the lower trim to release the nine clips and the one retaining tab.
  - Unplug the accessory socket connector, and remove the lower trim.

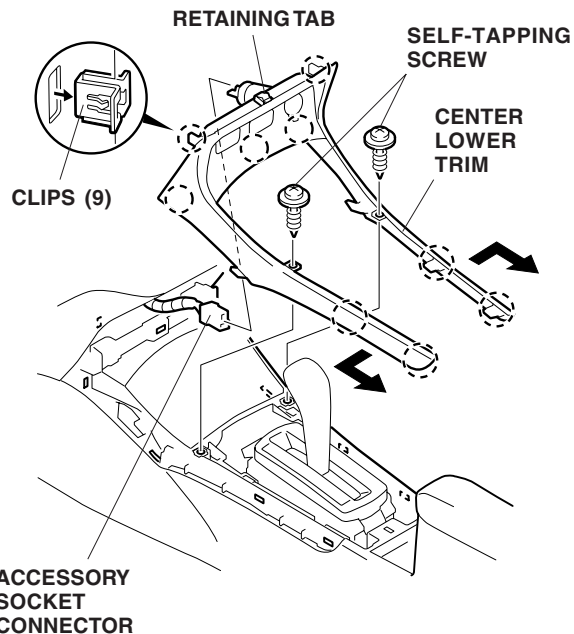

- Remove the four self-tapping screws that fasten the center lower switch panel to the center lower trim, and remove the switch panel from the trim.

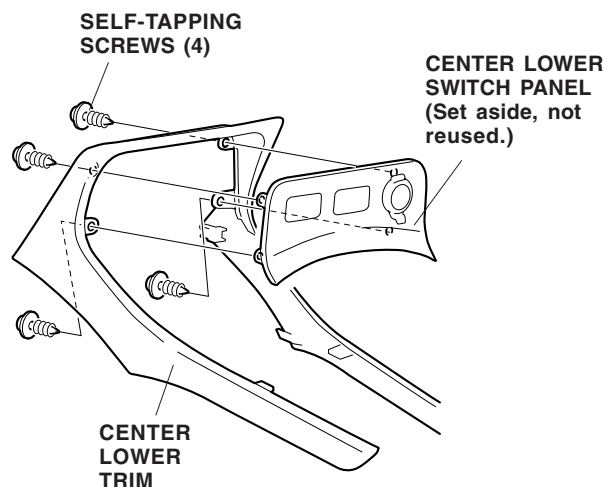

9. Check the color of the bulb located on each in the rings. The ring with the blue/green bulb belongs in the 4-door model; the ring with the clear bulb belongs in the 2-door model.

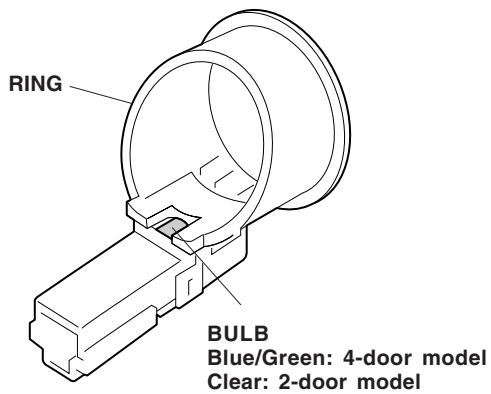

10. Slide the ring into the cutout in the new center lower cover by aligning its locating tab with the cutout in the lower cover.

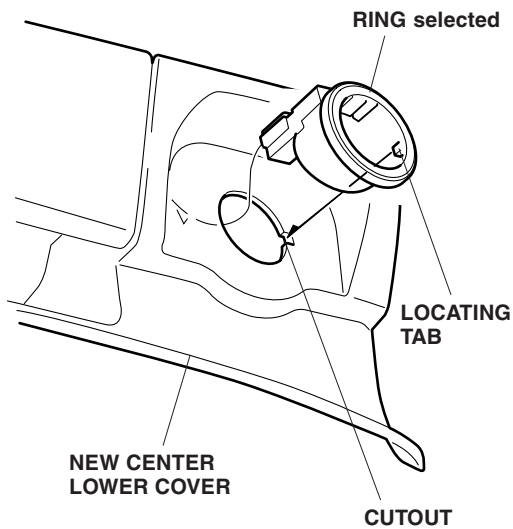

11. Slide the socket into the ring by aligning the locating tab with the cutout in the ring, then install the knob.

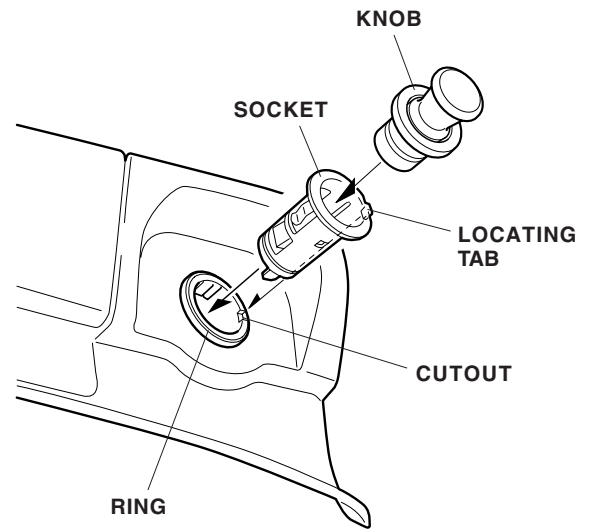

12. Position the new center lower cover on the center lower trim, and install the four self-tapping screws.

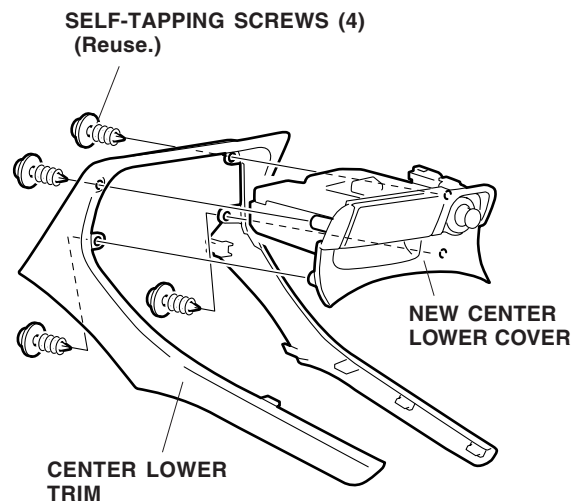

13. Install the cigarette lighter with ashtray:

- Plug the lighter harness into the cigarette lighter. Plug the accessory power socket connector into the cigarette lighter.
- Slide the illumination bulb into the cigarette lighter.
- Route the other end of the lighter harness from the dash opening to the fuse box, and secure it to the vehicle harness with one wire tie in the area shown.
- Install the screw grommet into the square hole in the vehicle bracket.
- Remove the ashtray from the new center lower cover. Install the cigarette lighter with ashtray assembly into the dash, and install the self-tapping screw provided.
- Install the ashtray.

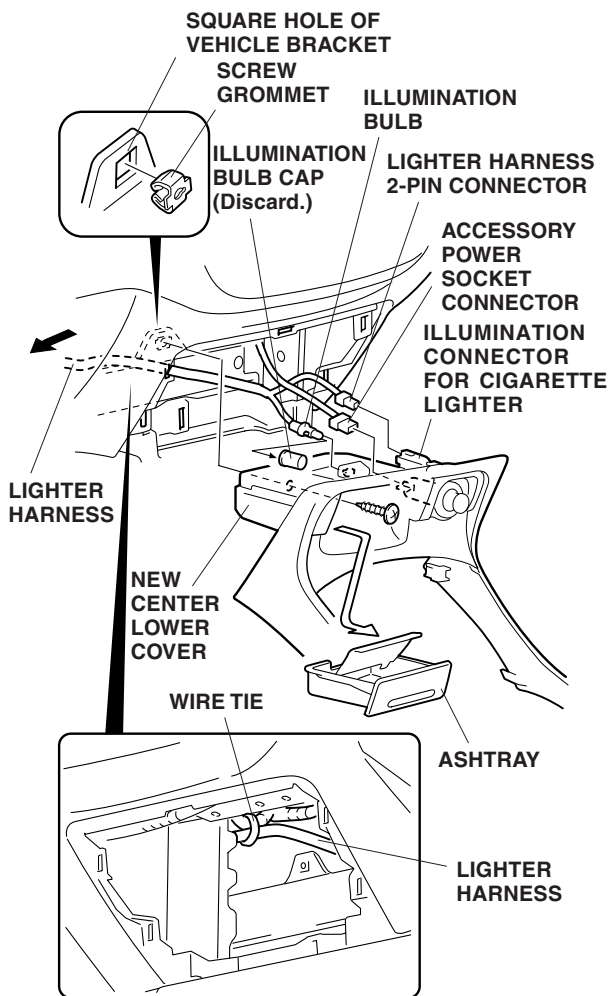

14. Plug in the lighter harness.

**A/T Model:** Remove a dummy connector from the lighter harness 6-pin connector. Unplug the vehicle 6-pin connector from the fuse box, and plug it into the lighter harness 6-pin connector. Plug the remaining lighter harness into the fuse box.

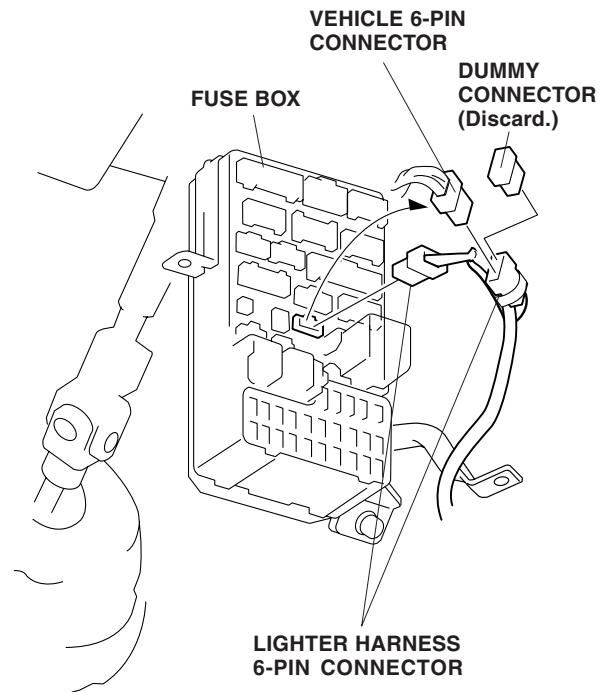

**M/T Model:** Plug the lighter harness connector directly into the fuse box, leaving the dummy connector in the lighter harness.

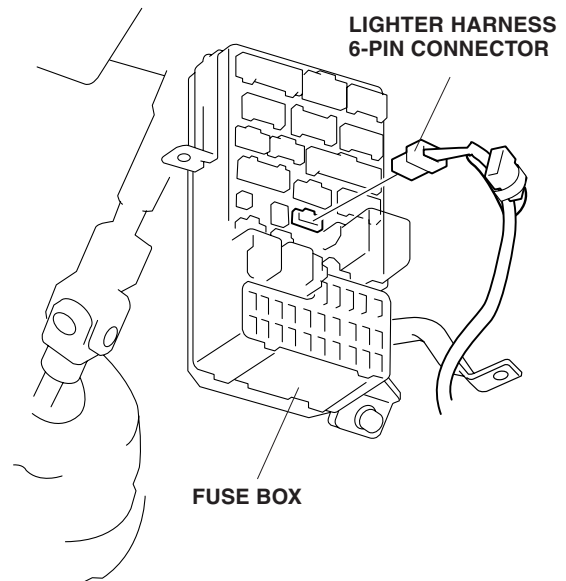

15. Secure the lighter harness to the vehicle bracket with one wire tie.

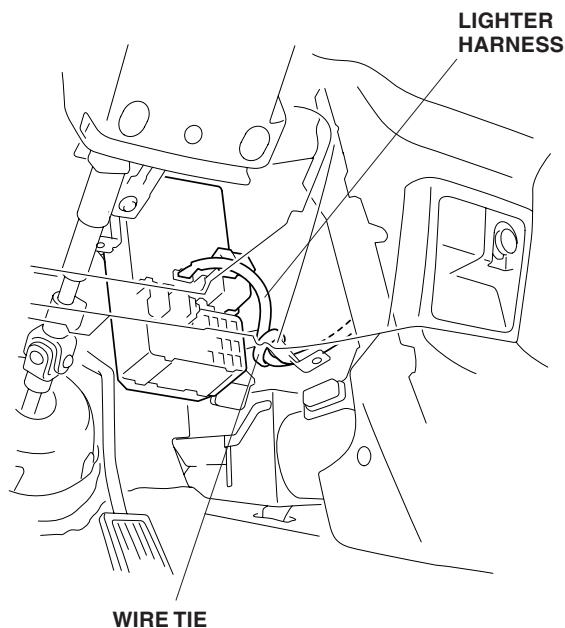

16. Reinstall all removed parts.
17. Reconnect the negative cable to the battery.
18. Check that the cigarette lighter heats properly when pressed in; open and close the ashtray several times to see that it works properly.
19. Enter the customer's radio anti-theft code, and reset the radio station preset buttons.
20. Reset the clock.

**NOTE:** Whenever the battery is disconnected, the driver's window AUTO function is disabled.

21. Start the engine. Push down on the driver's window switch until the window is fully open.
22. Pull up on the driver's window switch to close the window completely, then hold the switch for at least 2 seconds.
23. Lower and raise the driver's window to check operation of the driver's window AUTO function.

24. Do the ECM/PCM idle learn procedure.

- Make sure all electrical items are turned off.
- Start the engine. Hold the engine speed at 3,000 rpm with no load (in Park or Neutral) until the radiator fan comes on.
- Let the engine idle for about 5 minutes with the throttle fully closed and with all electrical items off.

**NOTE:** If the radiator fan comes on during this step, the time when it is operating must not be included in the 5 minutes.